

DOI: <https://doi.org/10.15480/882.9153>

ORCID: <https://orcid.org/0000-0003-2432-2357>



Webinar Series

Hydrogen and Hydrogen Derivates - Possibilities and Constraints

10.01.2024

The significance of hydrogen derivates

Part 1 - Background

Fabian Carels, Martin Kaltschmitt

Anstieg der globalen Oberflächentemperatur* im Vergleich zum vorindustriellen Niveau (1850 bis 1900), Fünfjahresdurchschnitt in Grad Celsius

ERA5-Daten weitere Quellen

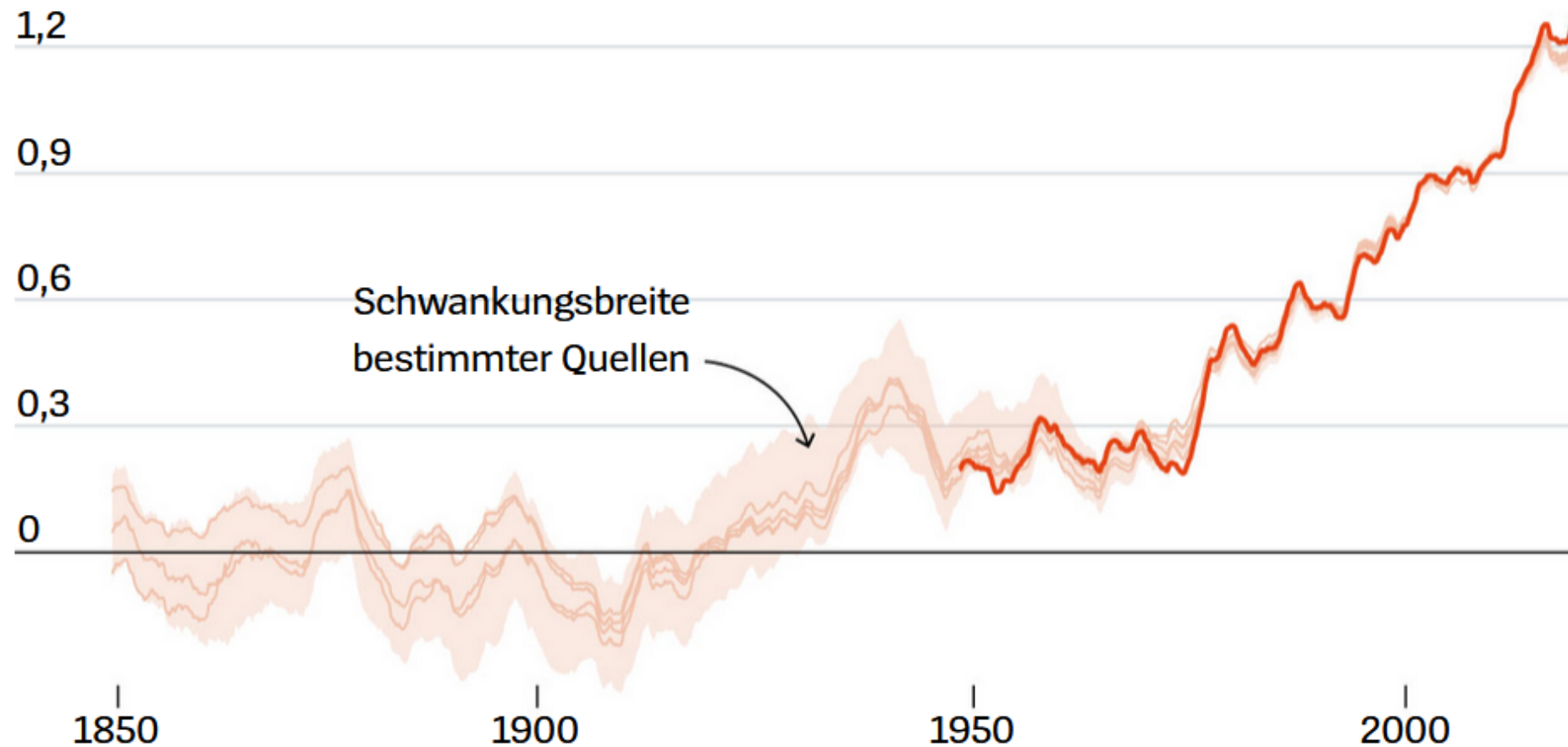

CO₂-concentration within the atmosphere

Atmospheric CO₂

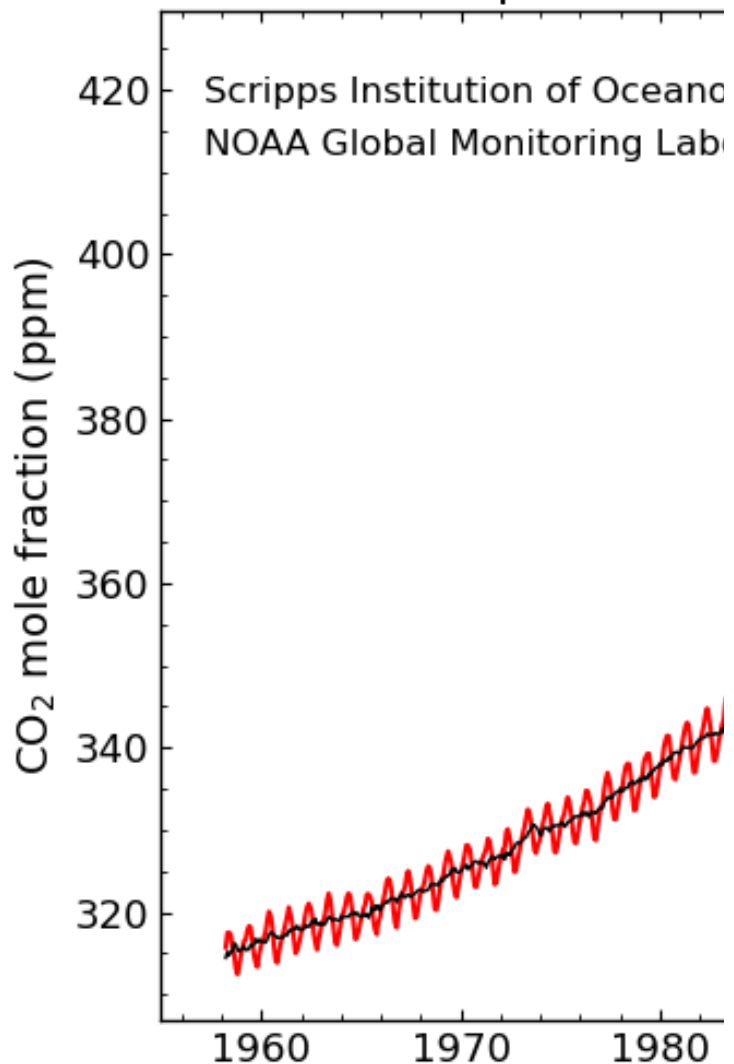

Recent Monthly Mean CO₂ at Mauna Loa Observatory

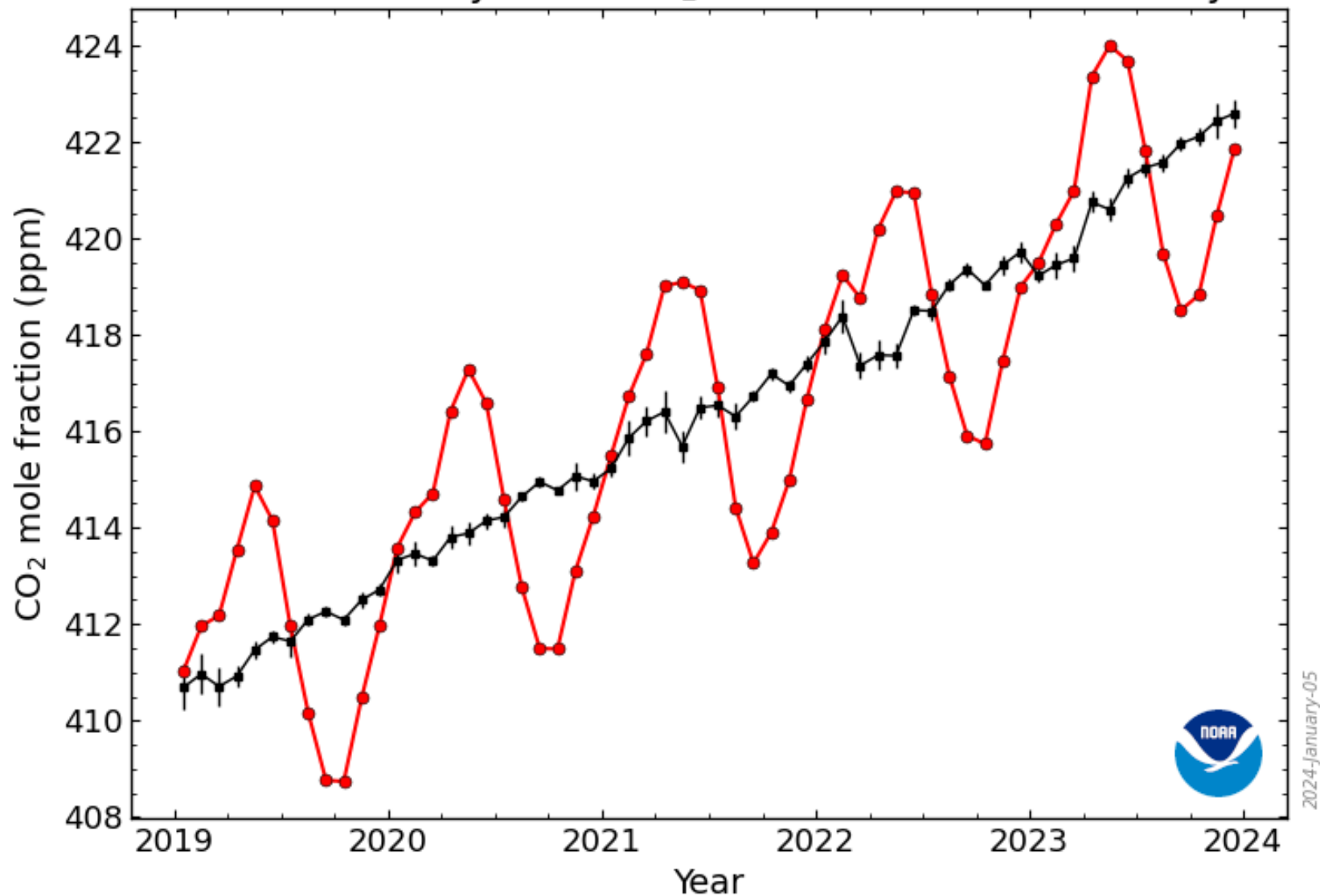

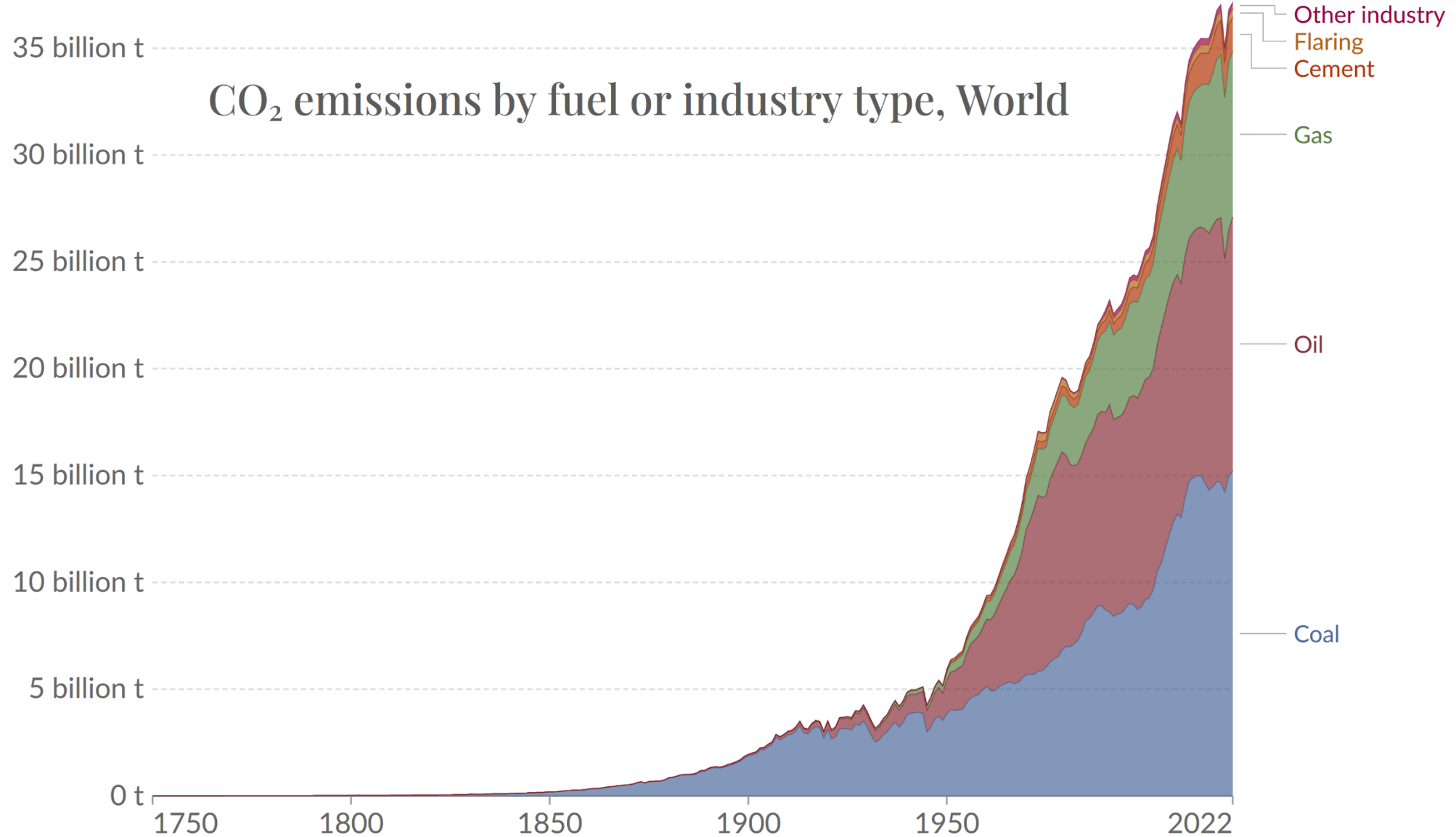



Fossil fuels must be replaced due to
... climate change mitigation
... depletion of the available limited resources
... increasing supply uncertainties due to political conflicts (e.g., Russian war on Ukraine, Red Sea)

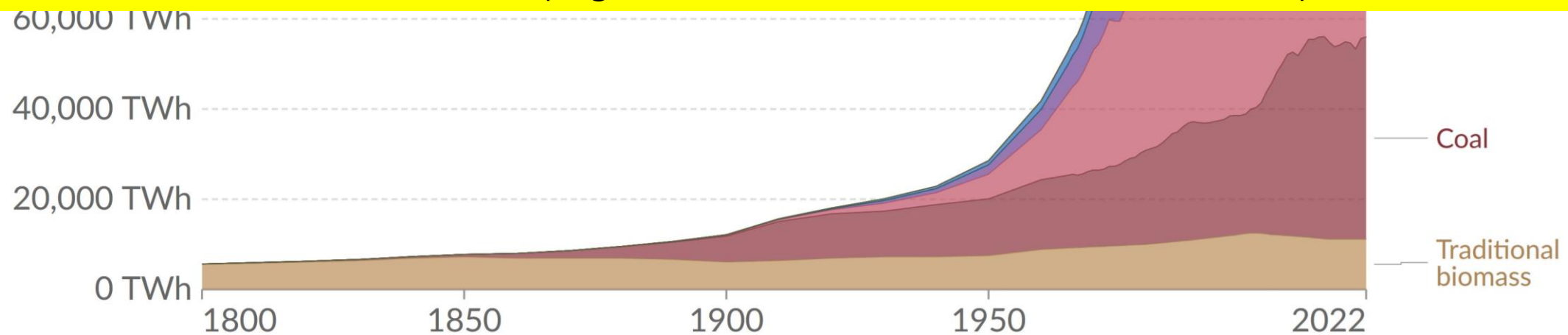

Installed wind energy capacity

Cumulative installed wind energy capacity including both onshore and offshore wind sources, measured in gigawatts (GW).

Our World
in Data

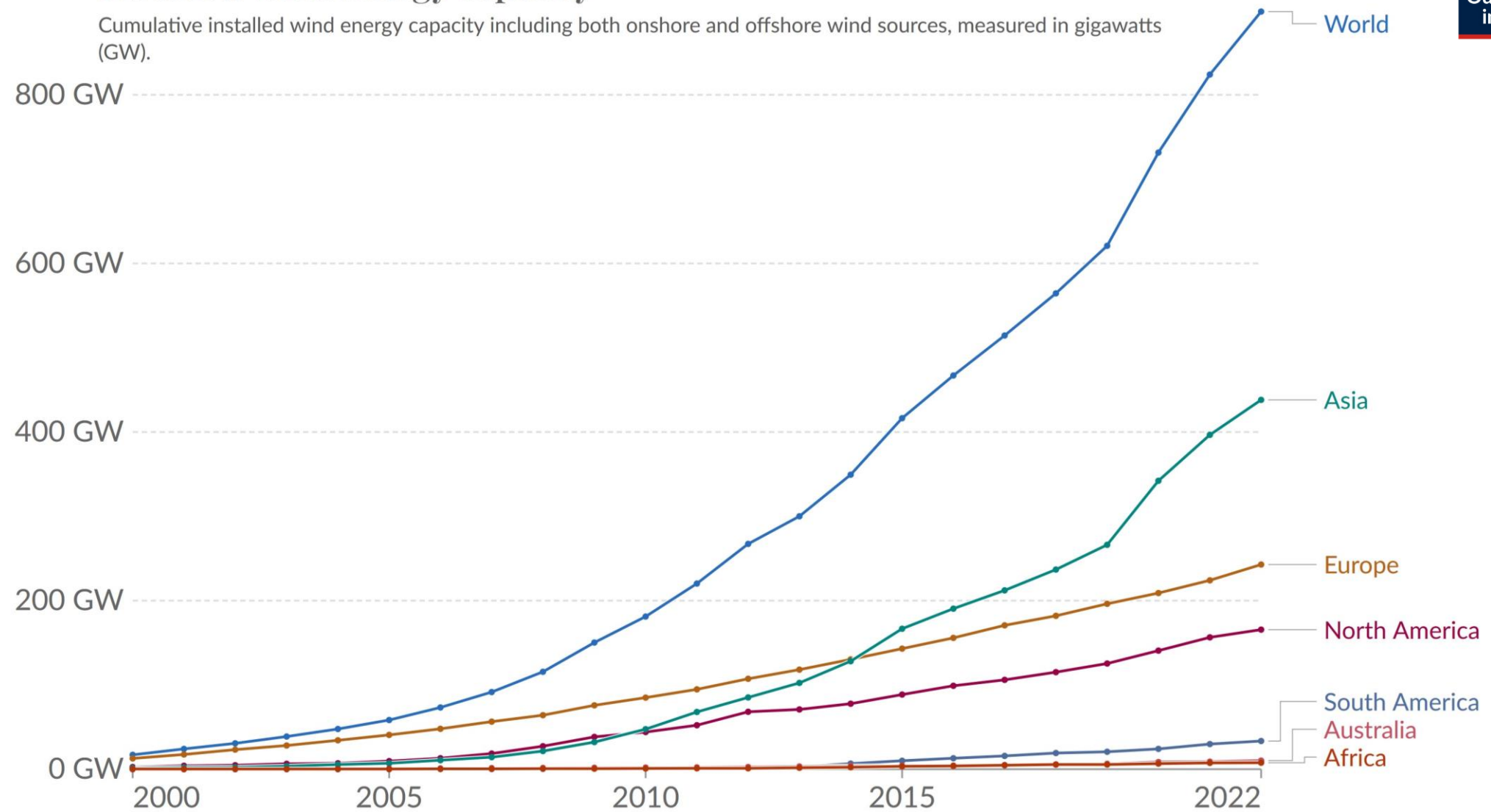

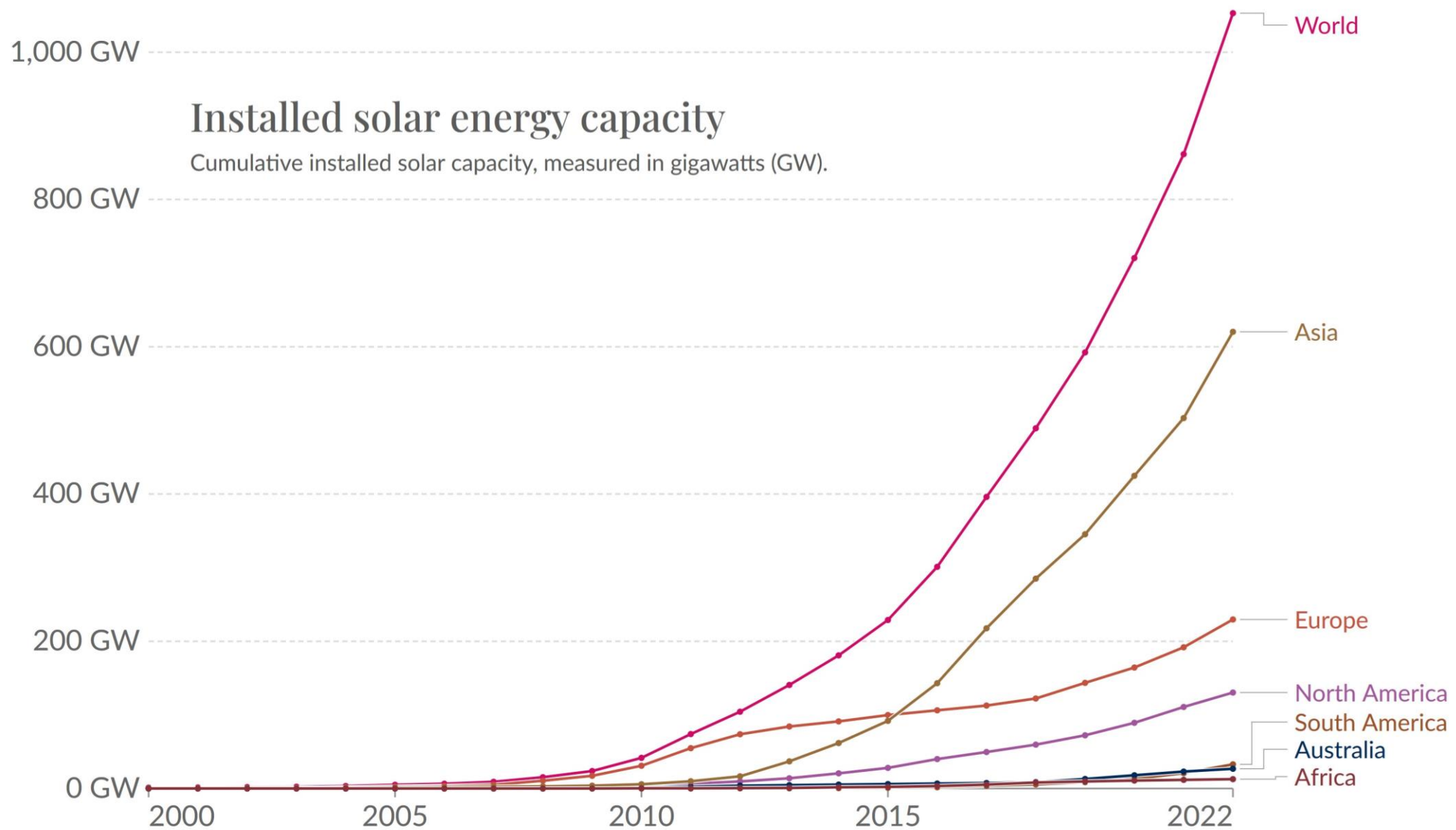

Global energy supply – Low-emission energy supply options

Modern renewable energy generation by source, World

Measured in terawatt-hours¹.

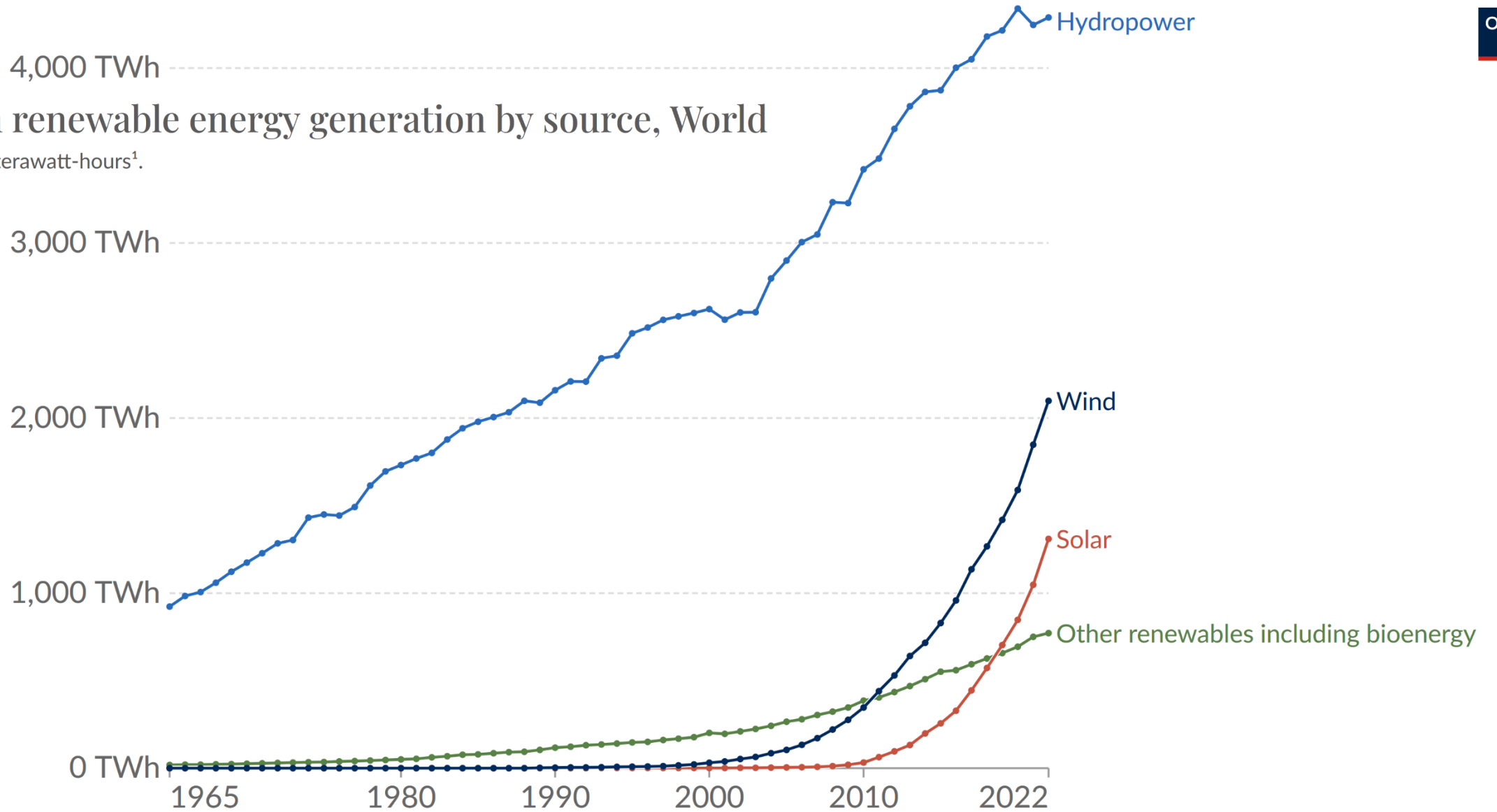

Global energy supply – Outlook low-emission supply options

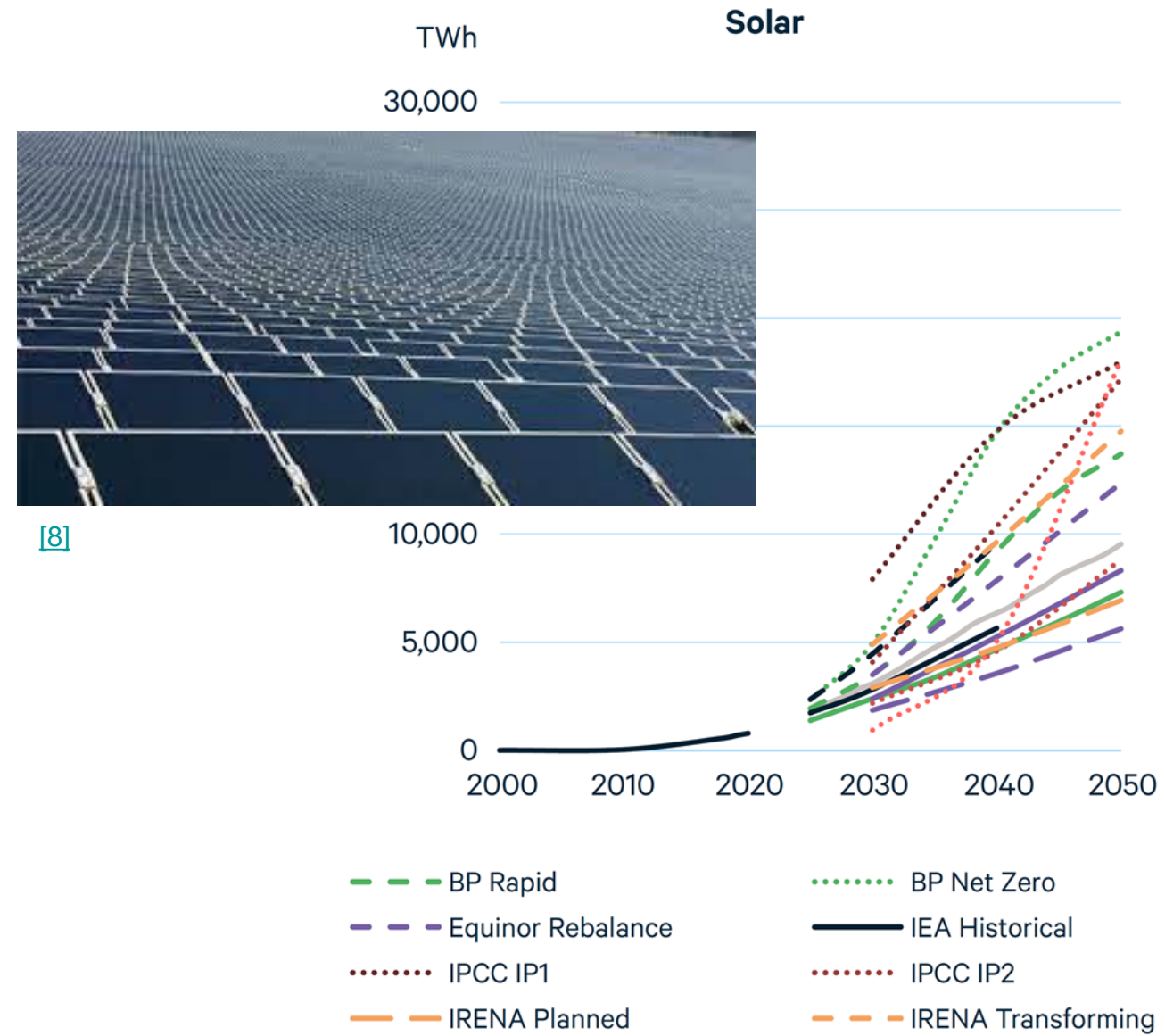
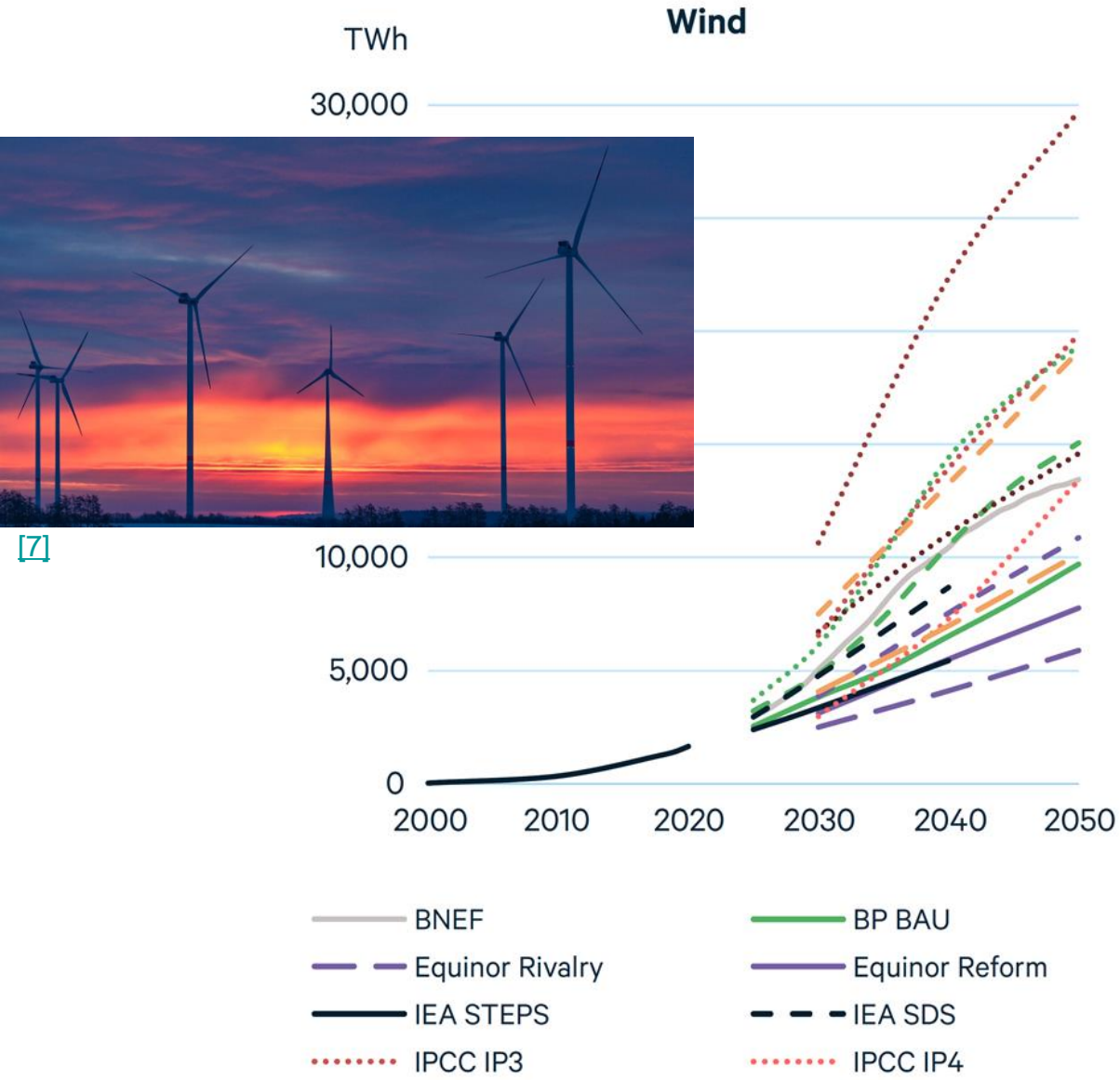

Global availability of renewable energies – Wind

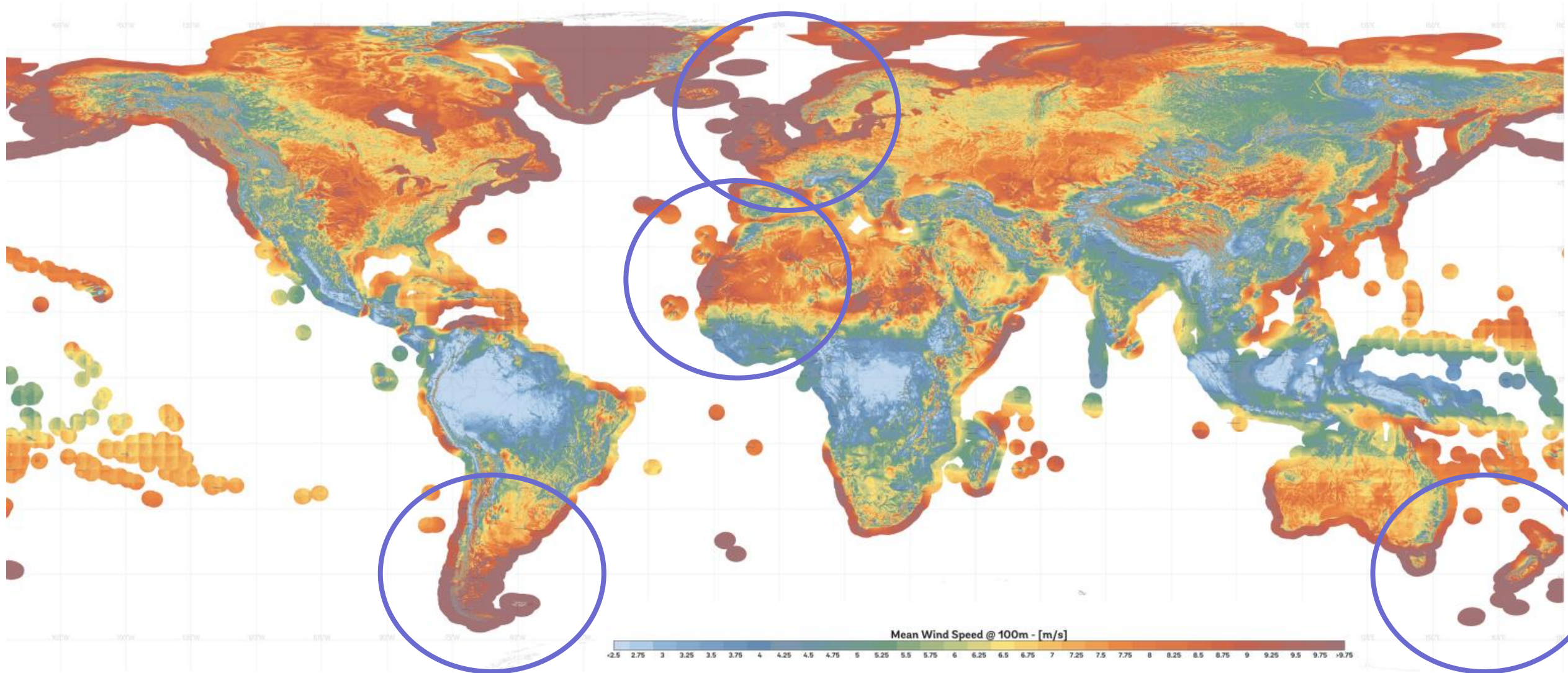

Global availability of renewable energies – Solar radiation

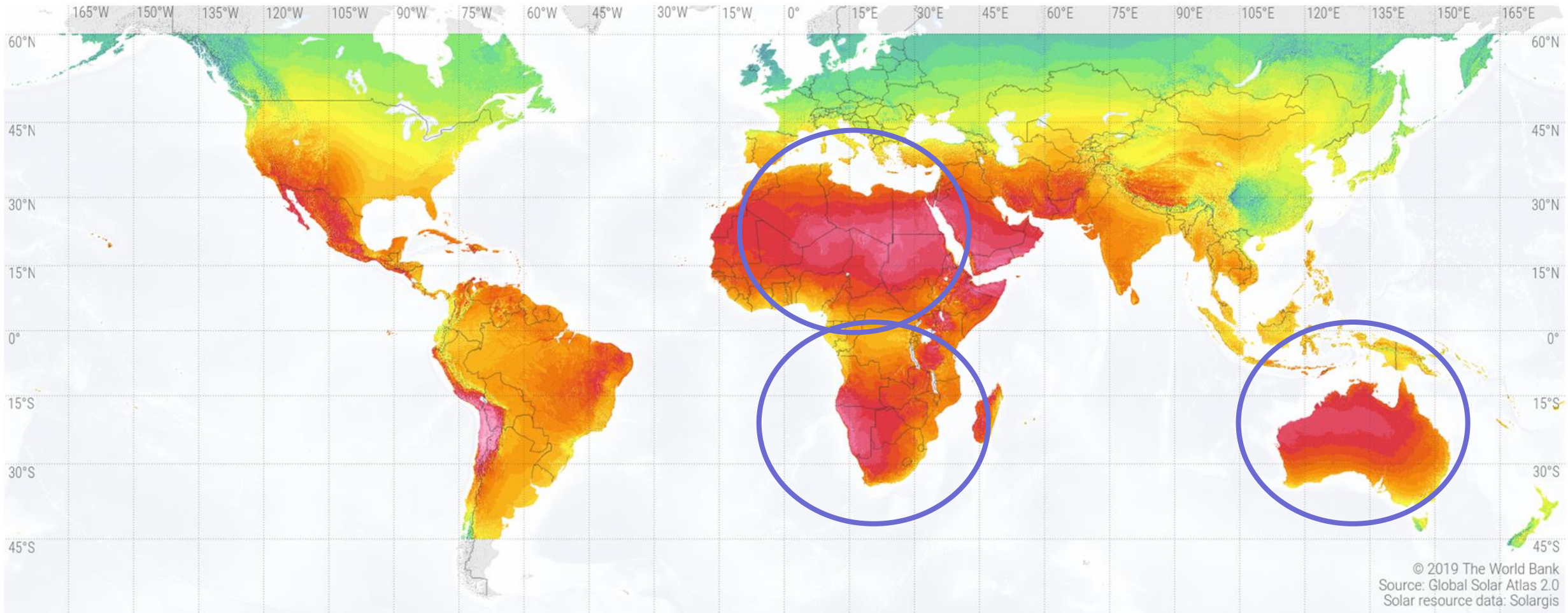

© 2019 The World Bank
Source: Global Solar Atlas 2.0
Solar resource data: Solargis

Long-term average of global horizontal irradiation (GHI)

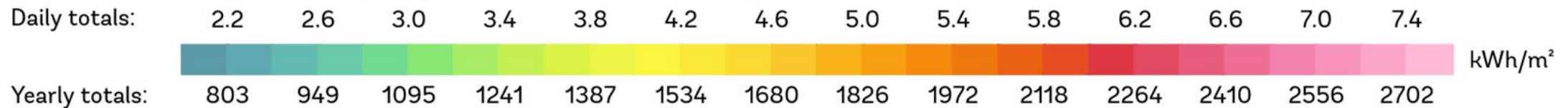

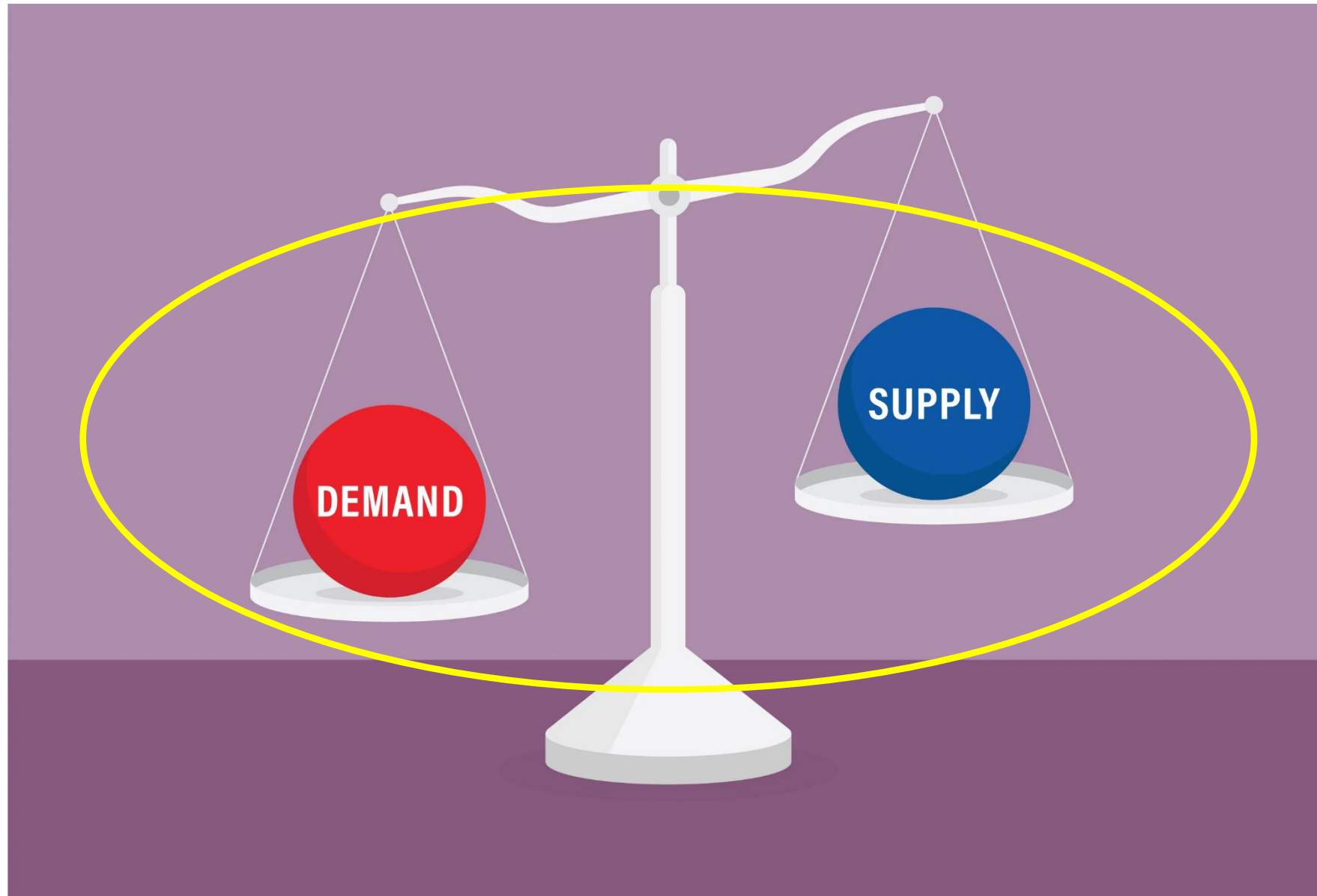

Energy demand centers – Energy use per person

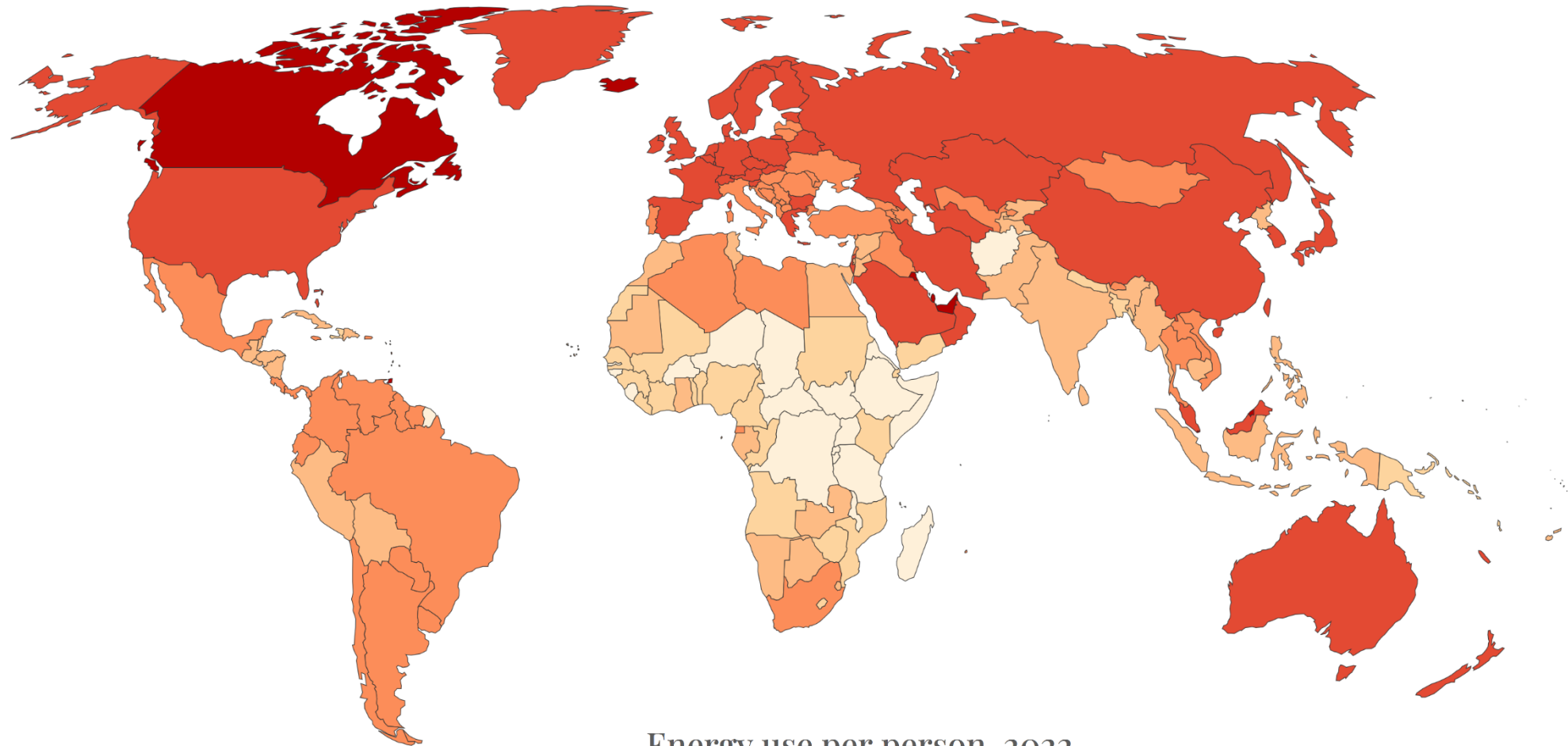

Energy use per person, 2022

Measured in kilowatt-hours¹ per person. Here, energy refers to primary energy² using the substitution method³.

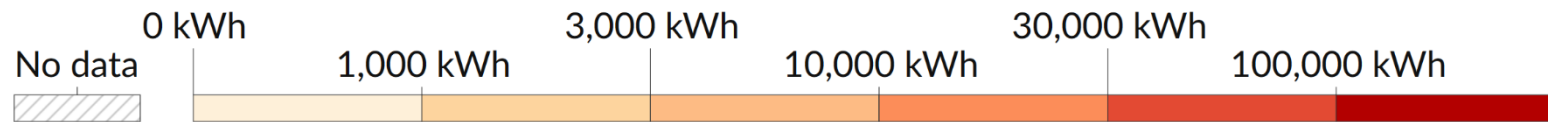

Energy demand centers – Overall primary energy consumption

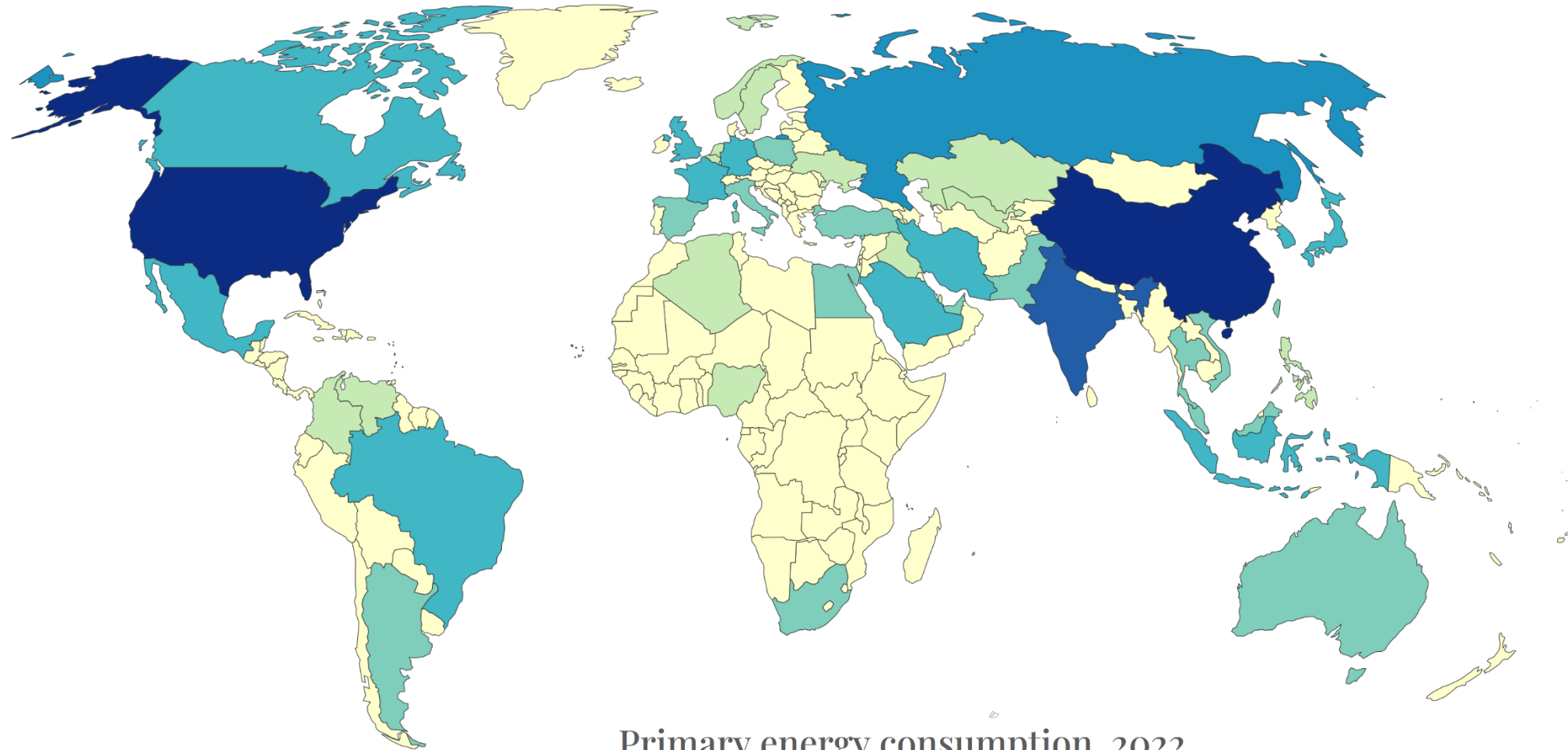

Primary energy consumption, 2022

Primary energy¹ consumption is measured in terawatt-hours², using the substitution method³.

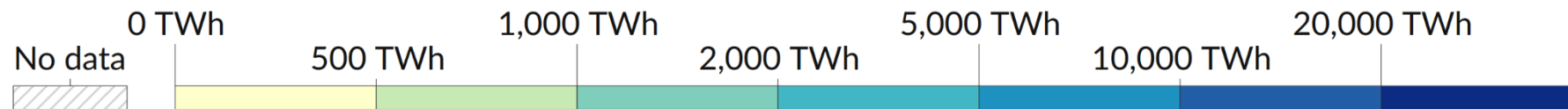

- ❖ Most likely, on a global scale the energy demand will continue to grow; if climate protection is taken serious the use of fossil fuels have to be substituted by renewable energy sources.
- ❖ The use of wind power and solar radiation contributes more and more to cover the given energy demand on a global scale – but still on a relative low level.
- ❖ From a potential point of view, technology wise and related to economics there is not “show stopper” preventing a fast expansion of an electricity provision from wind and solar. But, promising potentials are regionally not congruent with the main global energy demand centers.
- ❖ The highest energy demand correlates with the population density and the industrialization level; i.e. China, India, US and Canada as well as Europe show a high & increasing energy demand – and limited easy accessible and economically usable wind and solar resources.
- ❖ Thus, like today, also in the years to come a global energy trade will be necessary to connect areas with a promising renewable energy supply and areas with a high energy demand – but in the future “green” energy need to be traded.
- ❖ Thus, the arising key question is how this “green” energy (basically “green” electricity provided from wind turbines and from photovoltaic systems) can be transported (and stored) in a most promising way.

Webinar Series
Hydrogen and Hydrogen Derivates - Possibilities and Constraints

10.01.2024

The significance of hydrogen derivates
Part 2 - Hydrogen transport options

Fabian Carels, Martin Kaltschmitt

„Green“ electricity

Benefits

- ❖ No / very low conversion losses
- ❖ All technology components available on a large scale

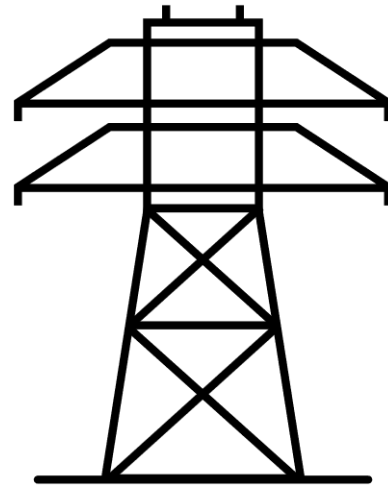

Limitations & Challenges

- ❖ Bound to inflexible infrastructure (power lines), → overseas transport not/barely possible
- ❖ Some sectors can't be electrified (e.g., aviation, steel)
- ❖ Large-scale storage technology not yet available (except pumped storage power plants)

„Green“ molecules

Benefits

- ❖ Easy integration of large-scale energy storage
- ❖ Development of flexible, global markets possible
- ❖ Use of hydrogen and/or hydrogen derivatives is potentially in (nearly) all sectors possible

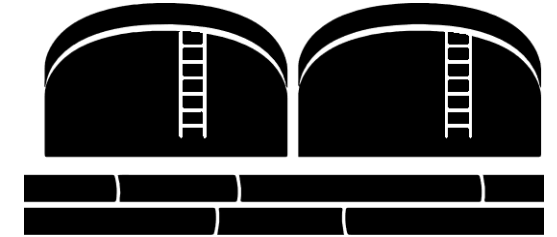

Limitations & Challenges

- ❖ Necessarily losses due to conversion from electrical energy into hydrogen and/or hydrogen derivatives
- ❖ Technological readiness and/or availability of some components currently not yet given

Transport options for molecules



Ships

Benefits

- ❖ Development of flexible, global markets possible
- ❖ Minimization of dependency on single



[14]

Pipeline

Benefits

- ❖ Minimal conditioning effort
- ❖ Low energy losses for pure hydrogen supply



[15]

Typically, both options do not compete and complement each other. Nevertheless, the basic precondition for cost-efficient transport of “green” molecules is an adequate conditioning of these molecules.

Limitations & Challenges

- ❖ Unavoidable losses due to conditioning
- ❖ Technological readiness and/or availability of some components currently not yet given

Limitations & Challenges

- ❖ Bound to inflexible infrastructure
→ overseas transport not/barely possible
- ❖ Potentially vulnerable to malfunctions, e.g. through sabotage

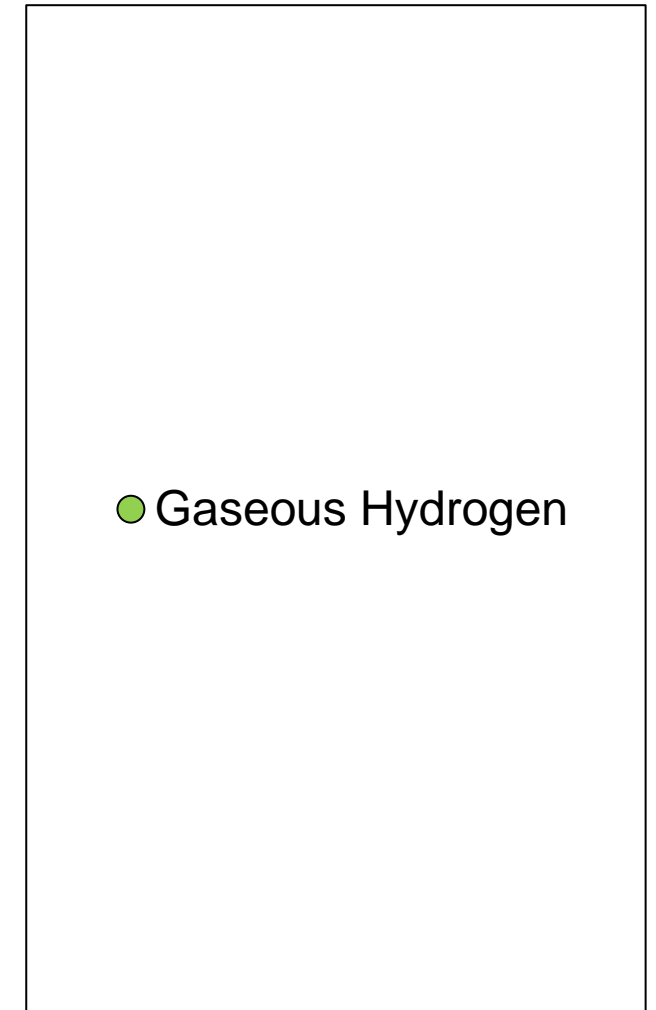
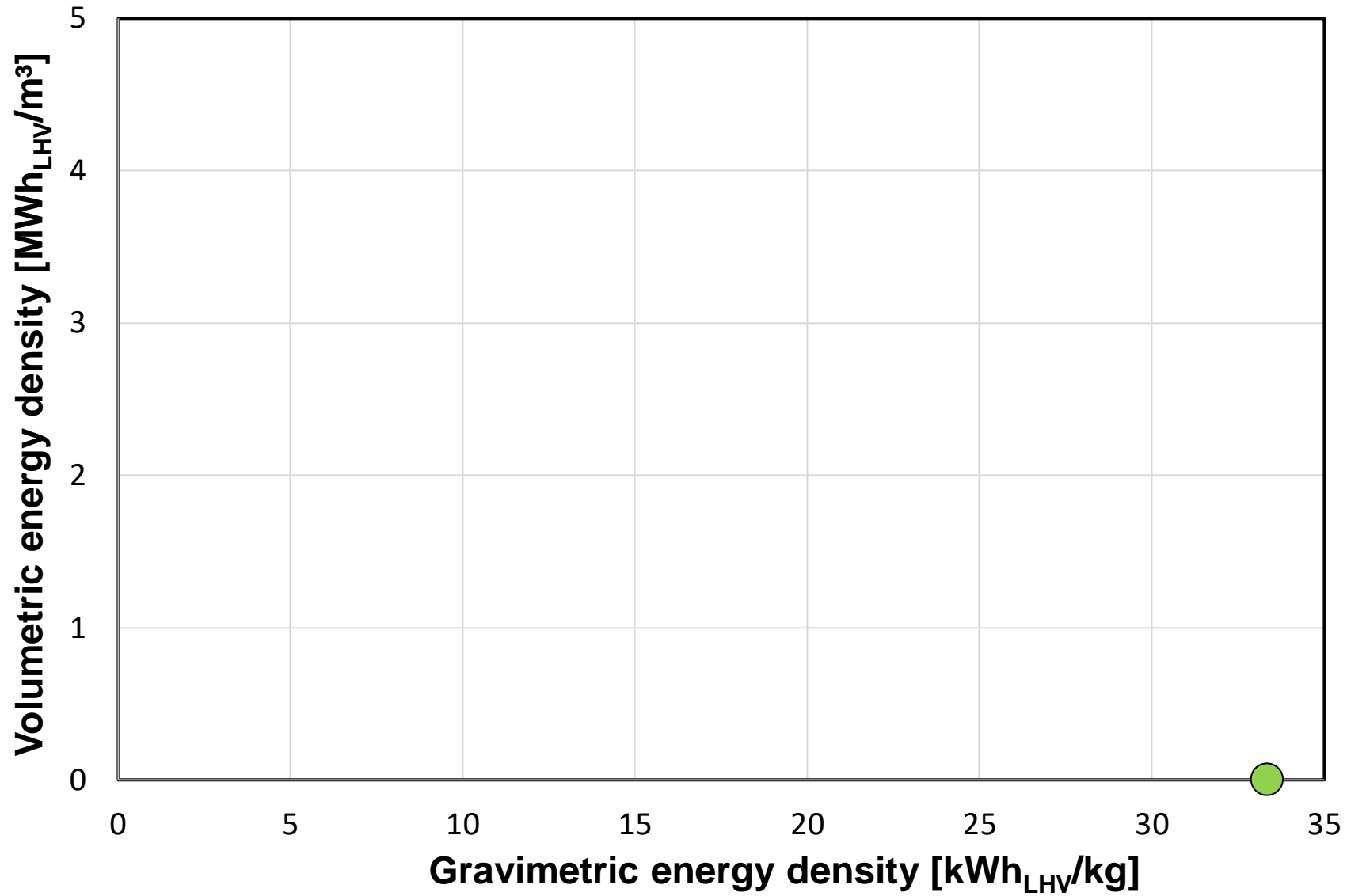

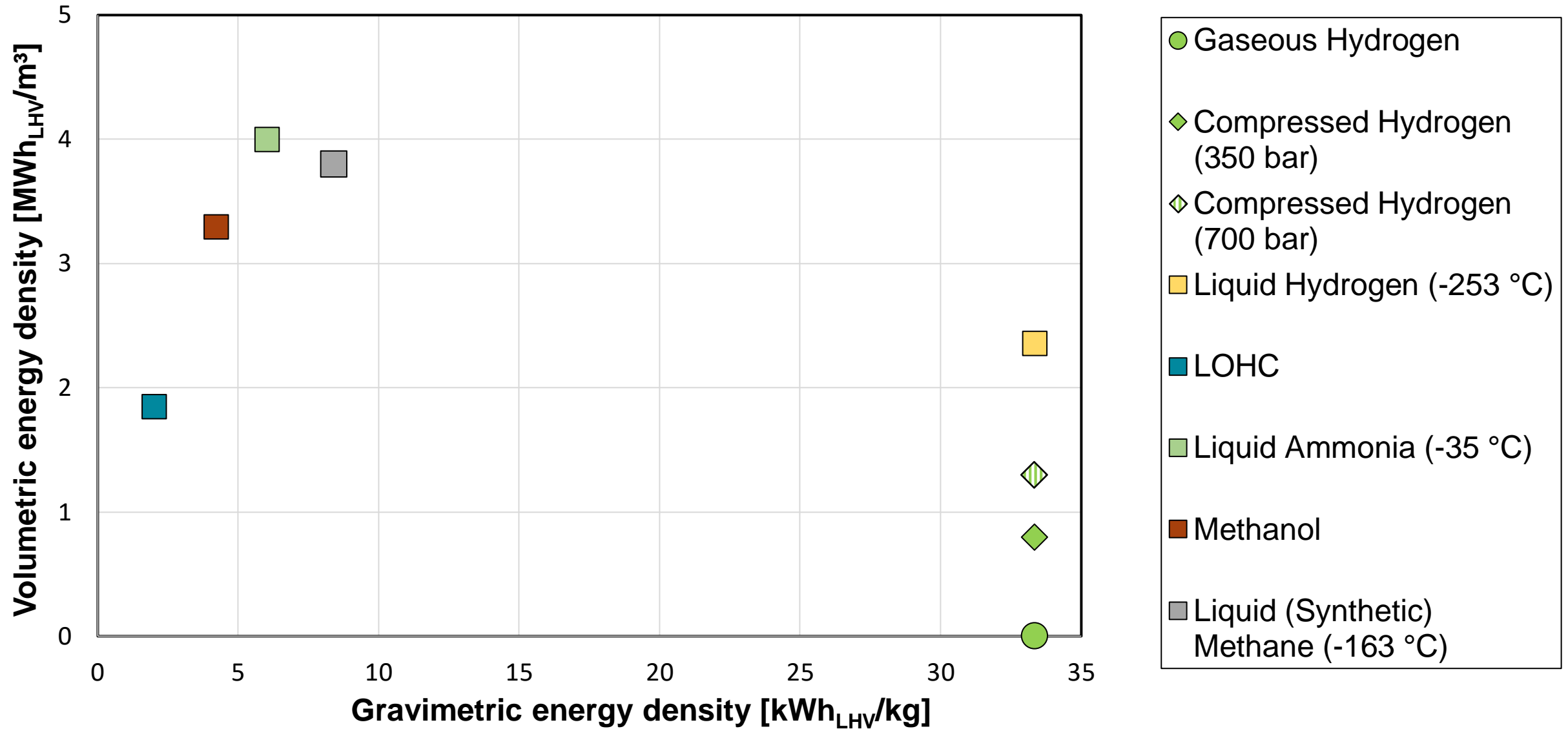

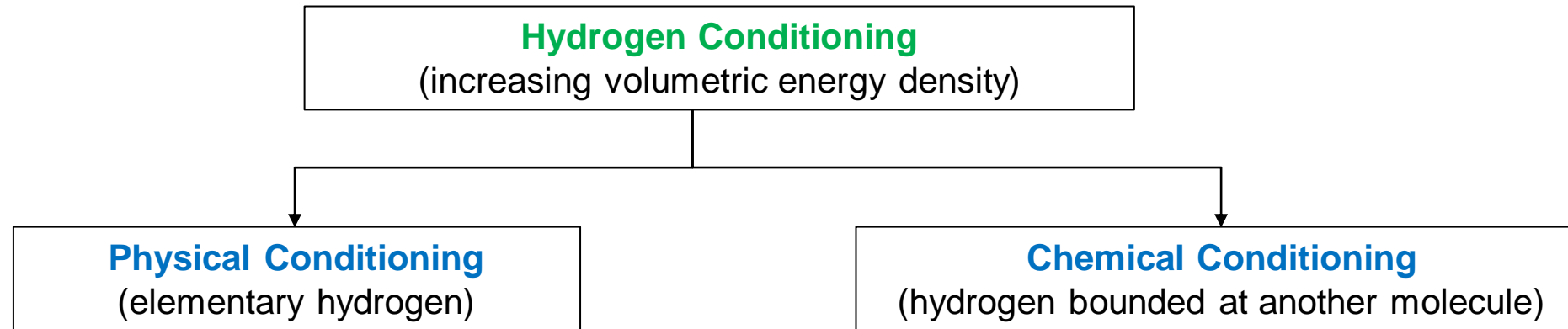

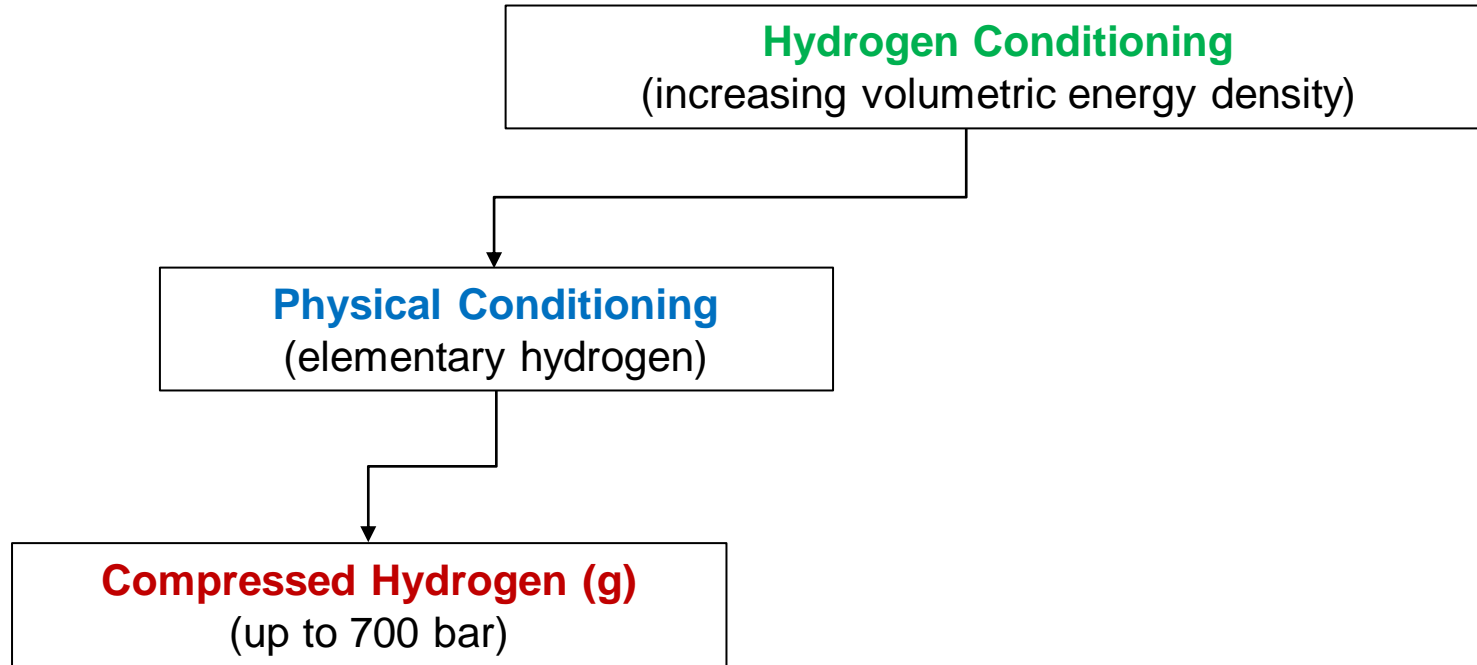

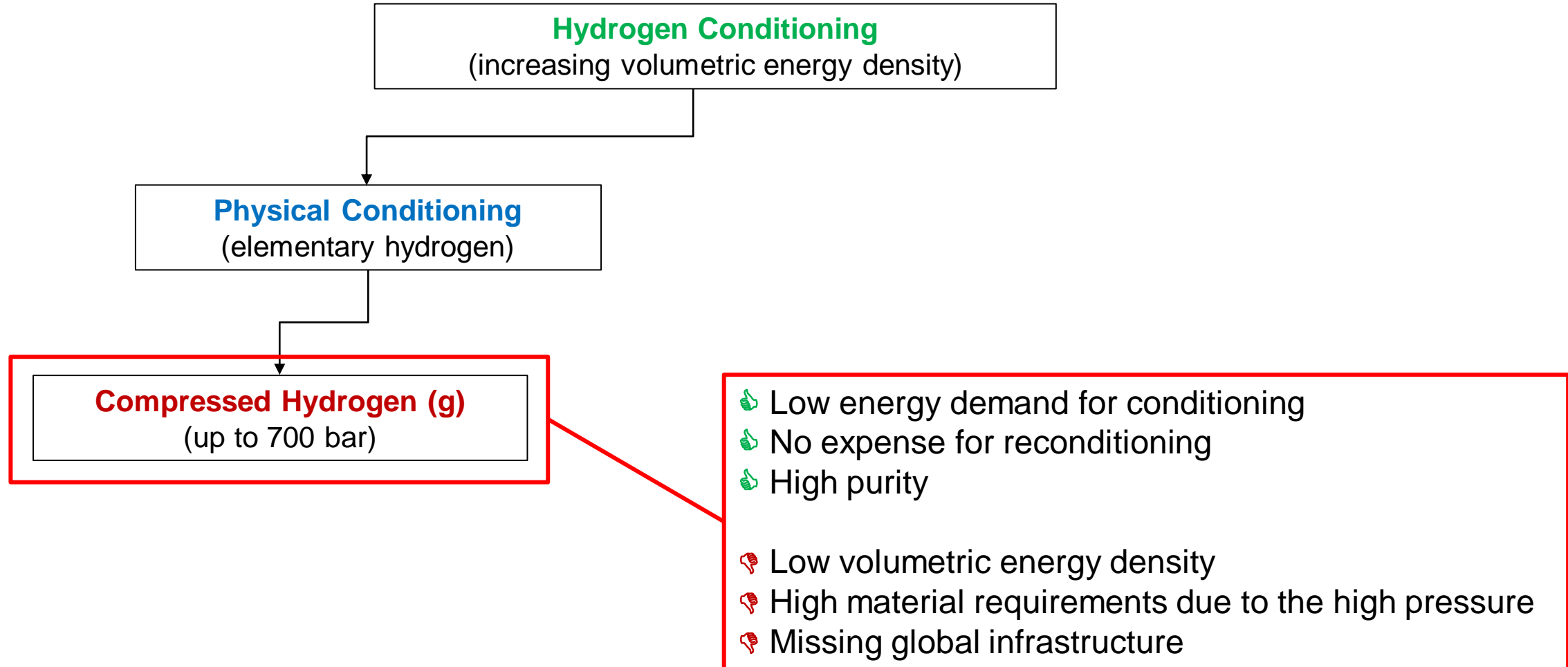

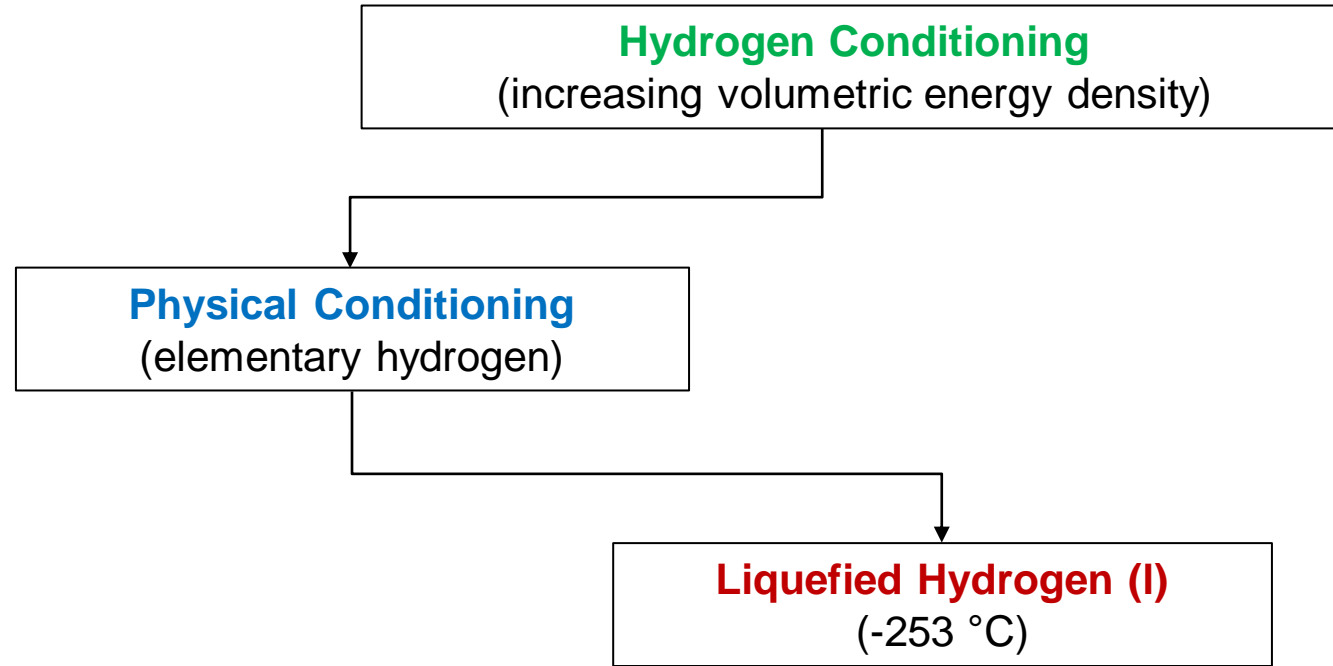

➔ Hydrogen needs to be cooled to 20 K (-253.15 °C) to become liquid.

Energy demand

- Theoretical minimum: 3.92 kWh/kg_{H2}
- State of the art: 10-13 kWh/kg_{H2}
- Long-term goal: 6.5 kWh/kg_{H2}

[17]

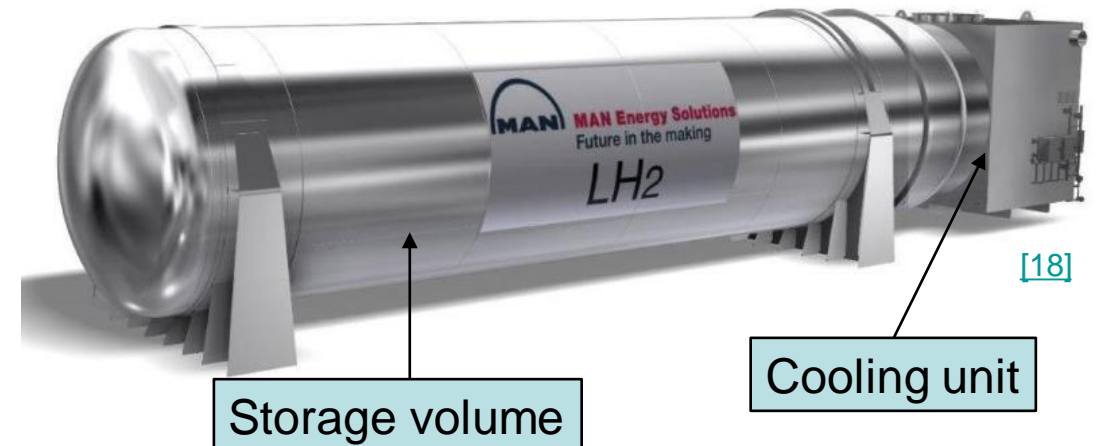
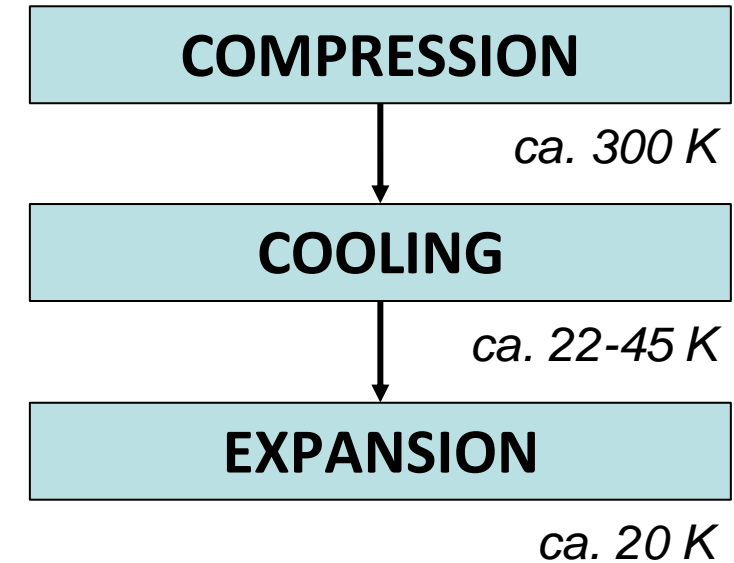

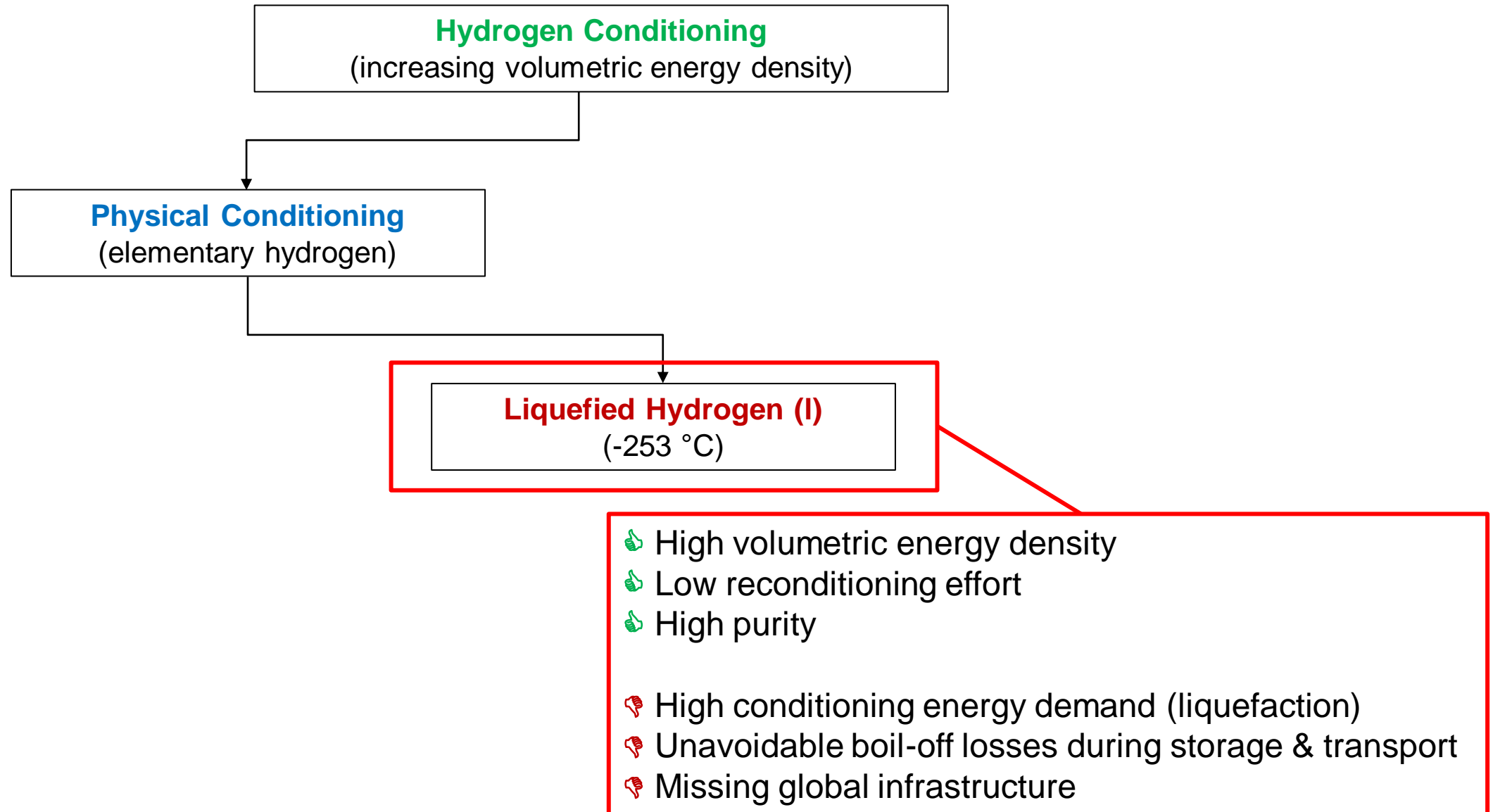

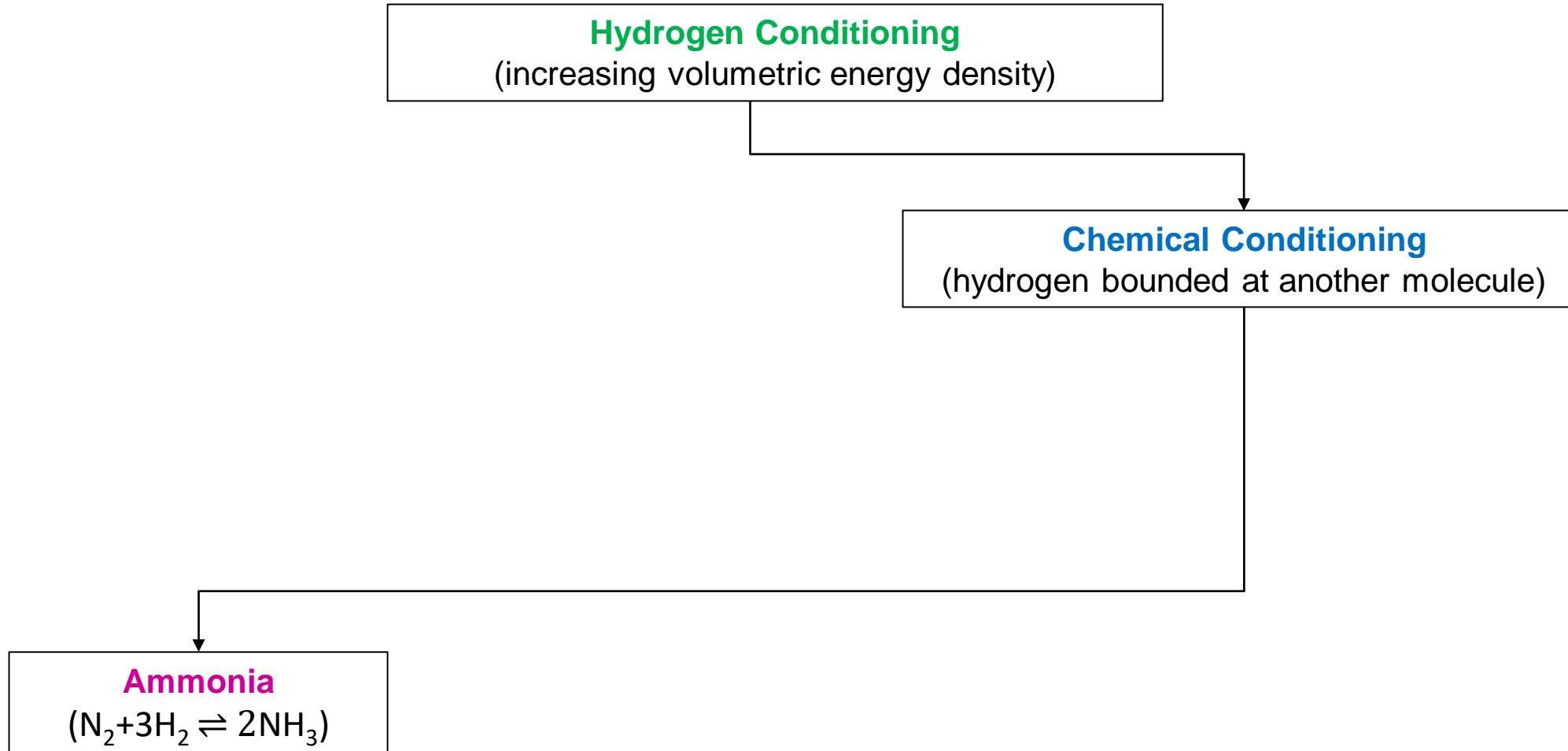

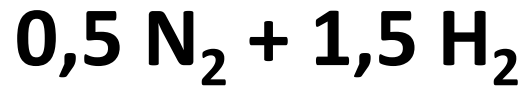

[19]

Haber-Bosch Synthesis

Exotherm $46 \text{ kJ/mol}_{\text{NH}_3}$
 $300 - 500 \text{ }^\circ\text{C}, 150 - 350 \text{ bar}$

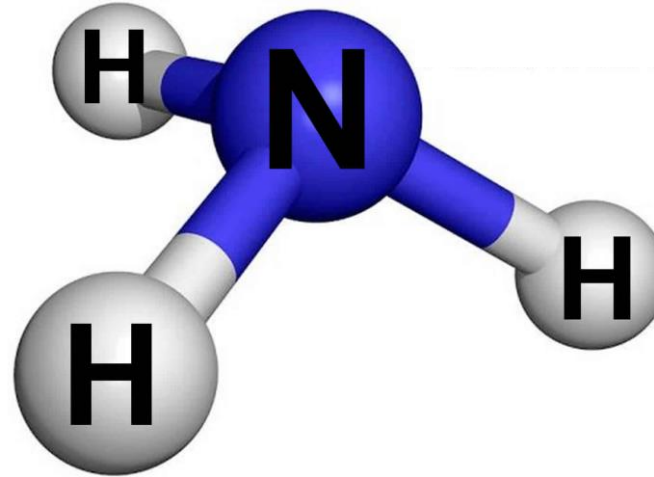

[20]

Ammoniak Cracking

Endotherm $46 \text{ kJ/mol}_{\text{NH}_3}$
 $500 \text{ }^\circ\text{C}, < 2 \text{ bar}$

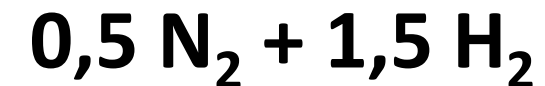

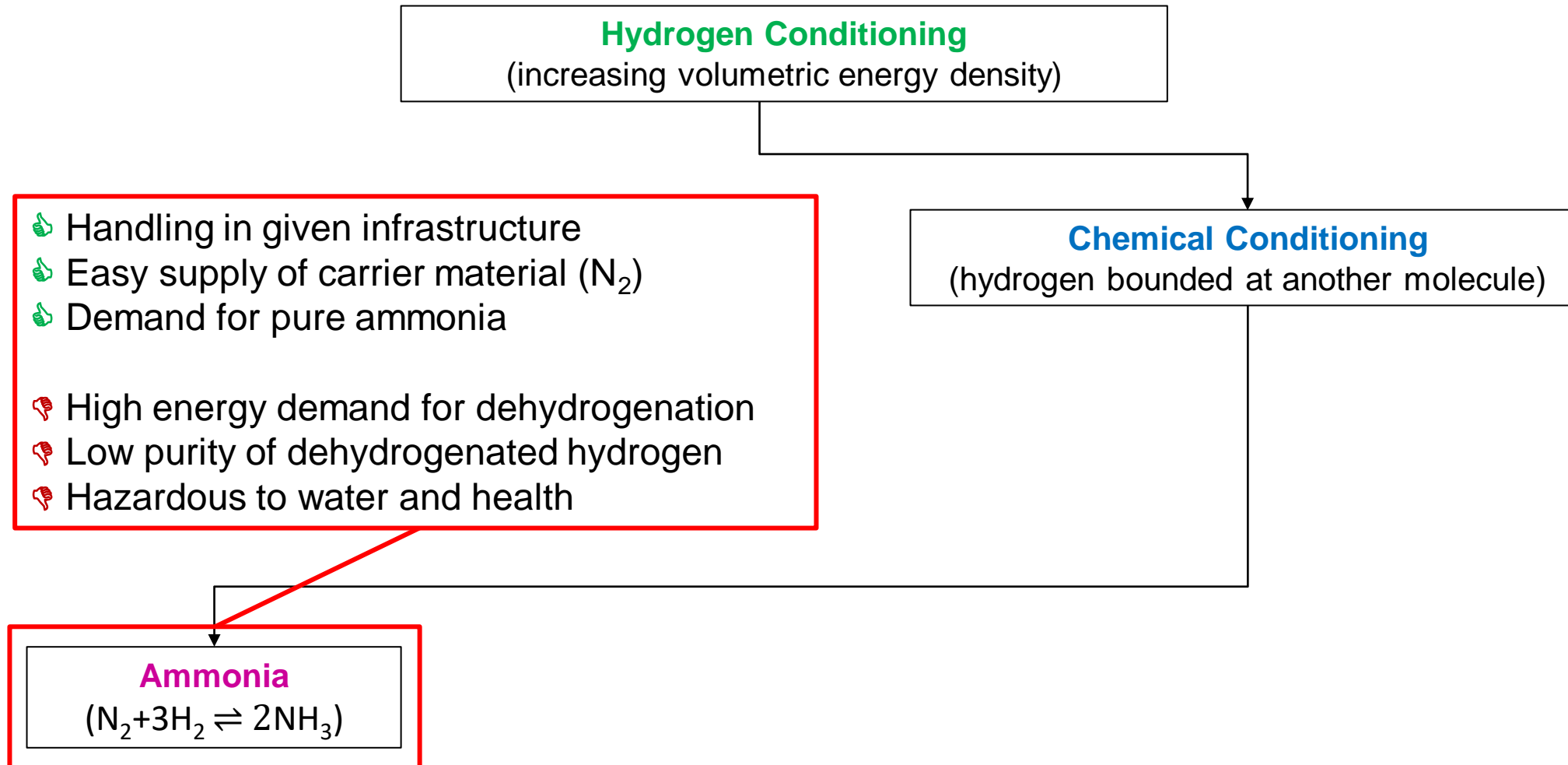

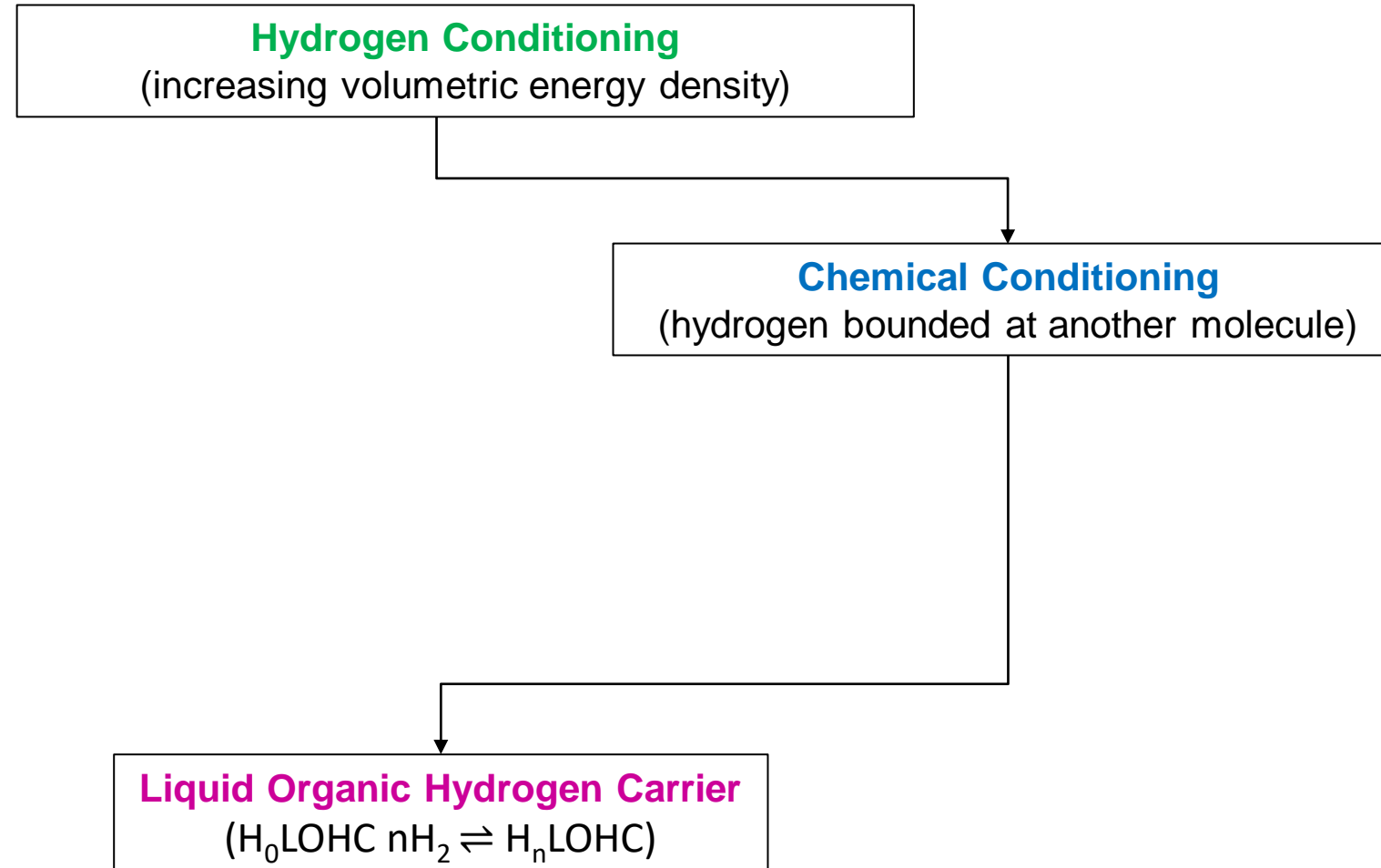

Dehydrogenated LOHC

Hydrogenated LOHC



[21]

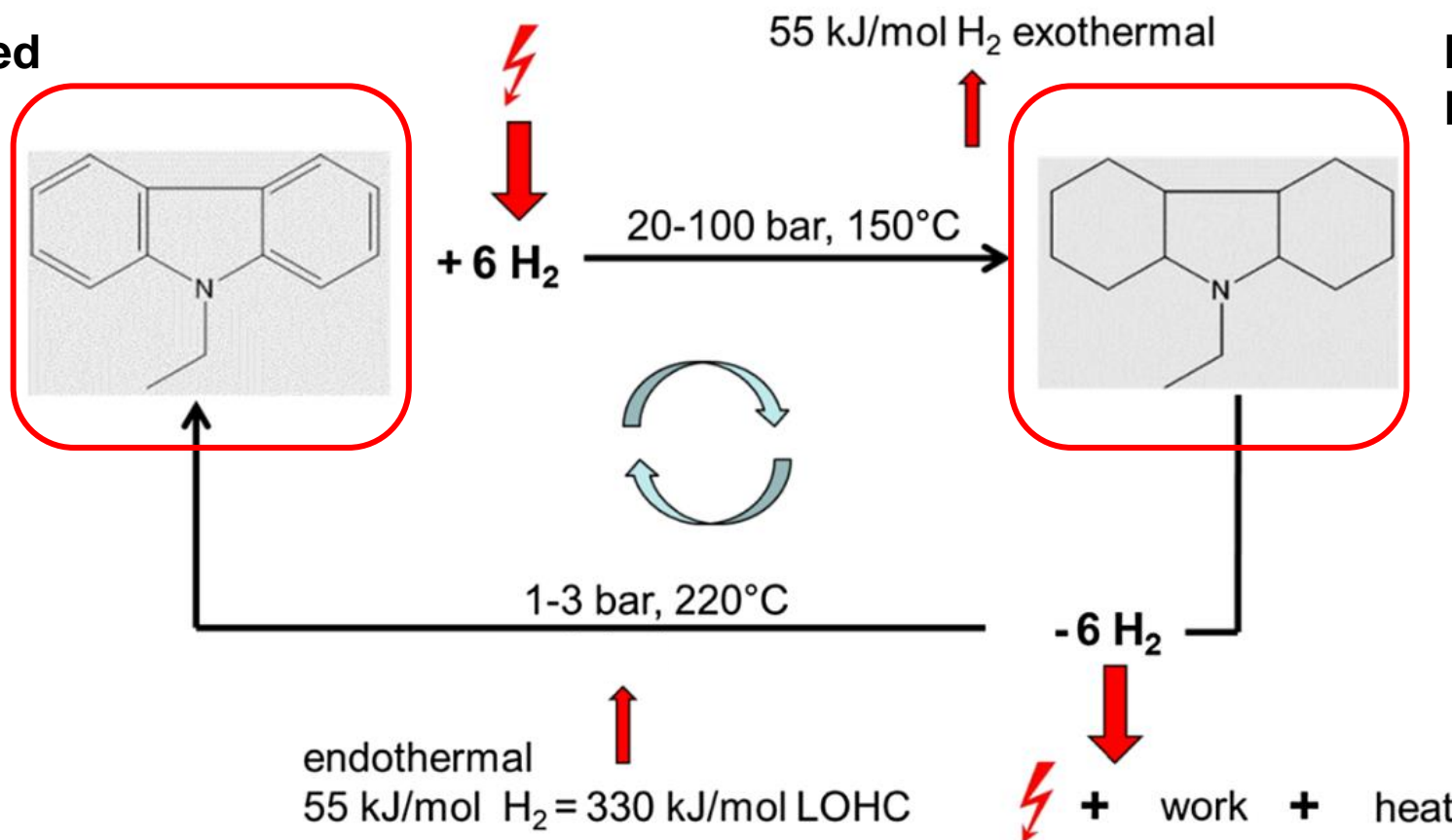

[21]

Hydrogen Conditioning
(increasing volumetric energy density)

- 👍 Easy handling in given infrastructure
- 👍 Transport & storage at ambient conditions
- 👍 Not flammable / explosive
- 👎 Very high energy demand for dehydrogenation
- 👎 High cost for carrier material
- 👎 Large-scale hydrogenation & dehydr. plants unproven

Chemical Conditioning
(hydrogen bounded at another molecule)

Liquid Organic Hydrogen Carrier
($H_0LOHC + nH_2 \rightleftharpoons H_nLOHC$)

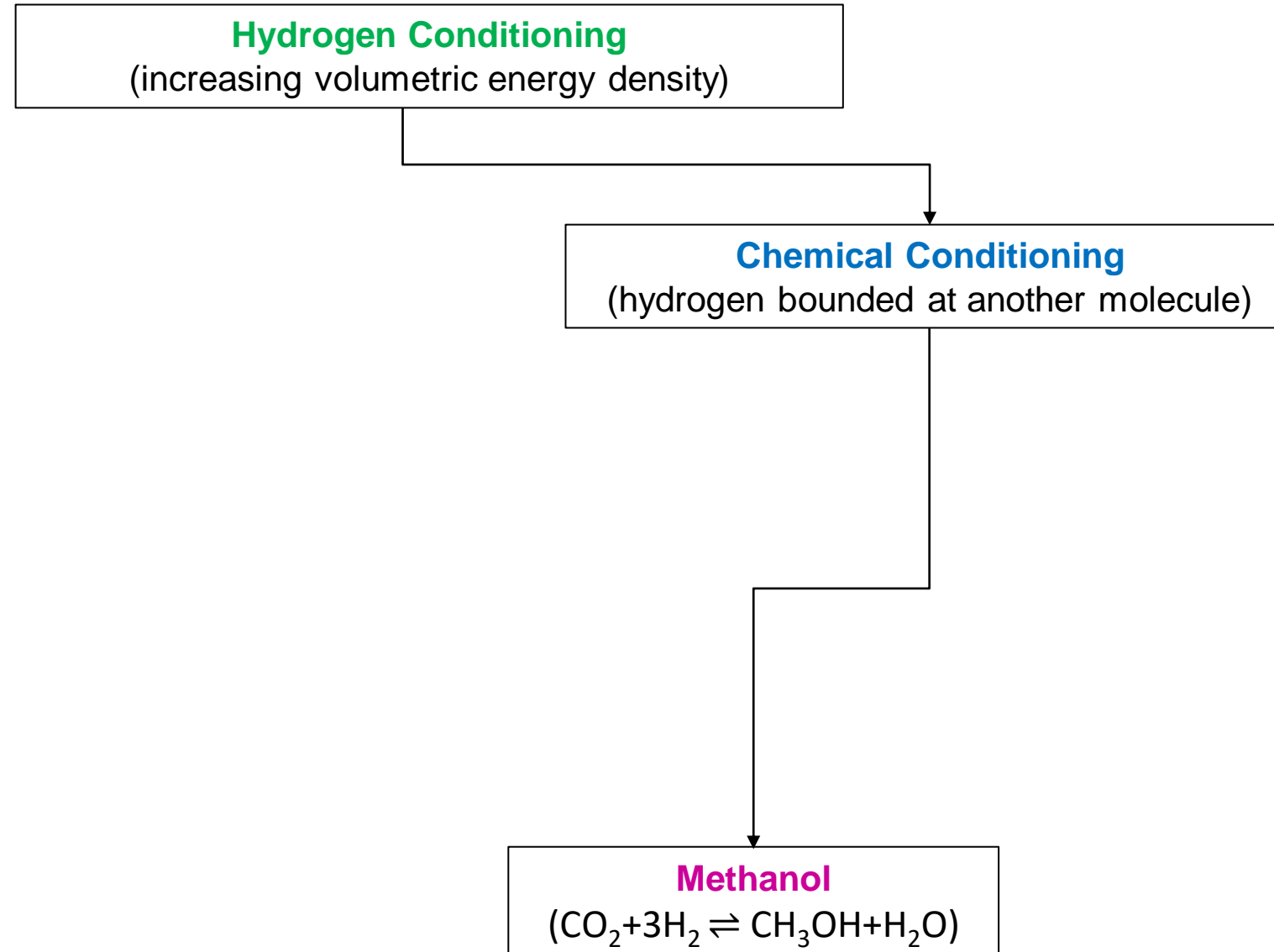

Methanol Synthesis

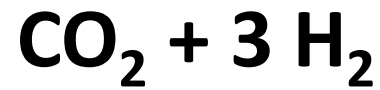

[22]

Exothermal
200 – 300 °C, 30 – 120 bar

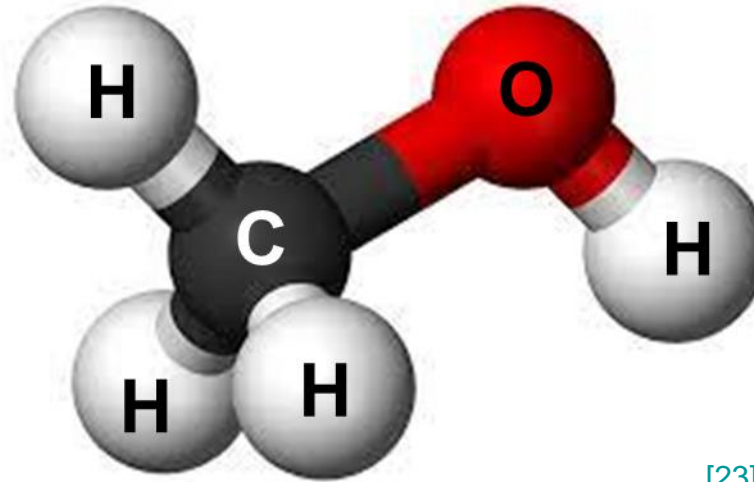

[23]

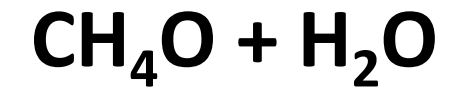

[24]

Methanol Reforming (e.g. Steam Reforming)

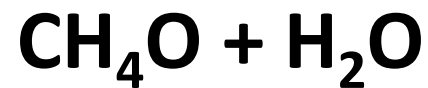

Endothermal
250 – 300 °C, < 20 bar

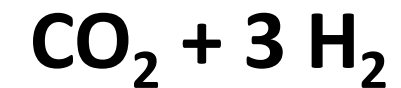

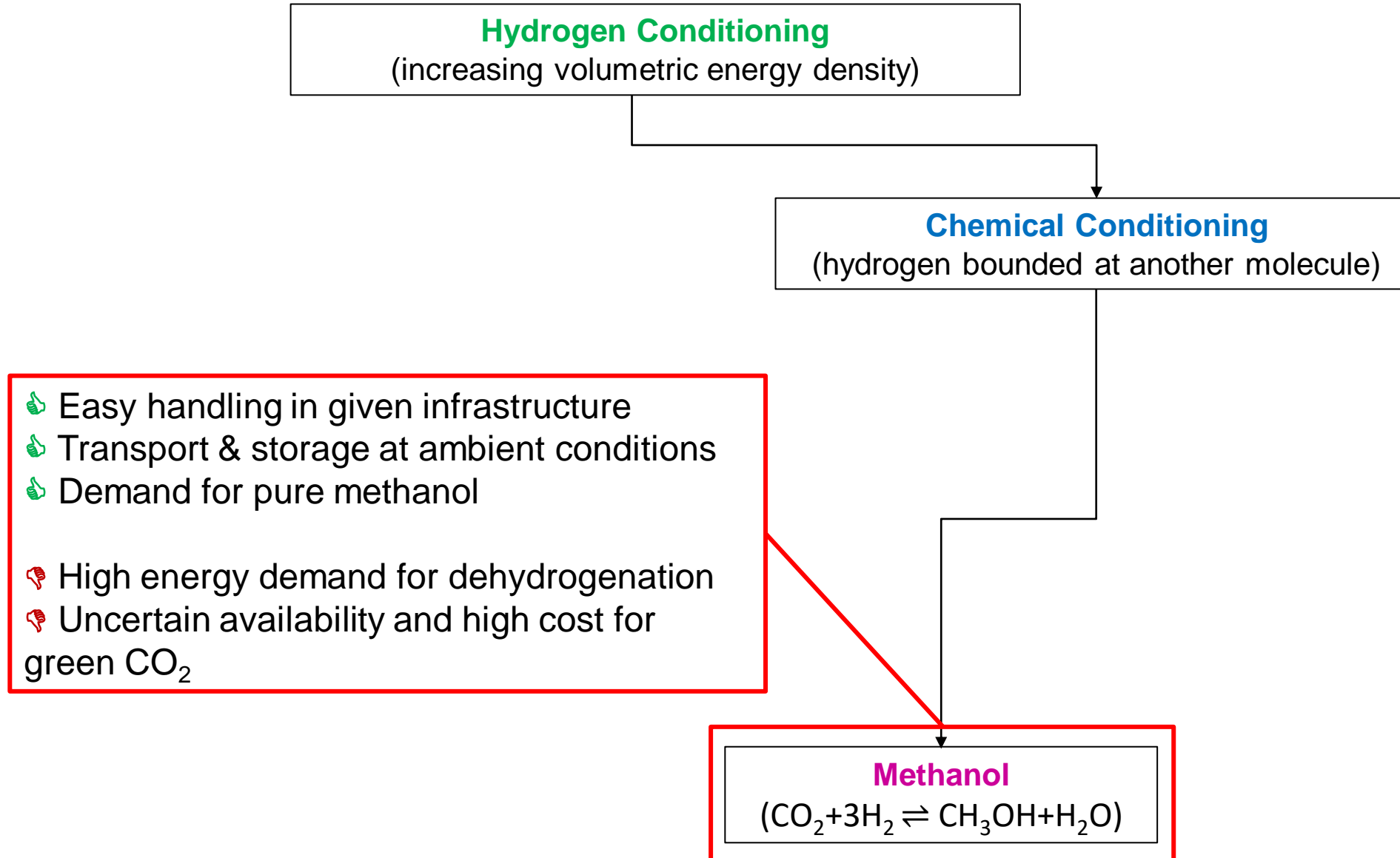

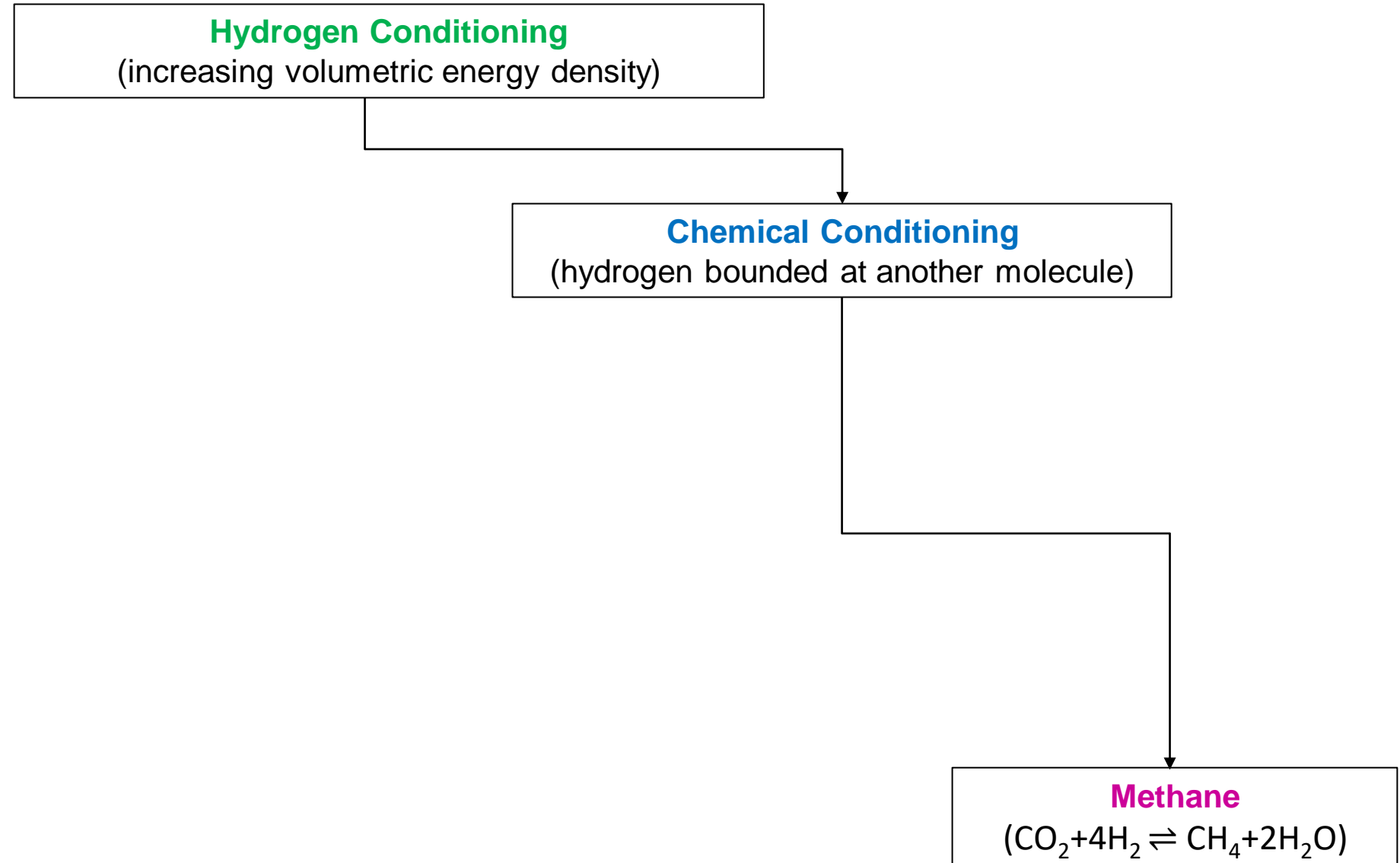

Methanation

Exothermal
250 – 550 °C, > 10 bar

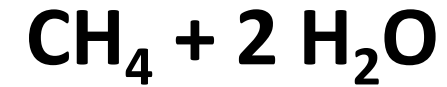
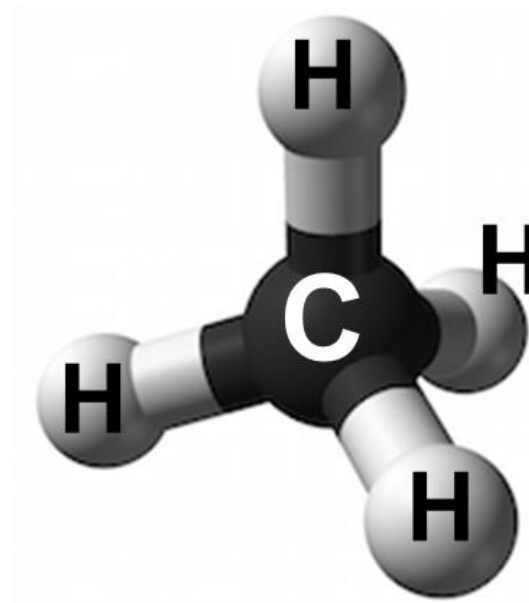
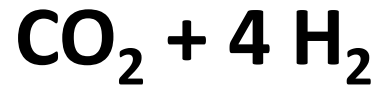

Methan Reforming (e.g., Steam Methane Reforming)

Endothermal
650 – 1000 °C, 5 – 40 bar

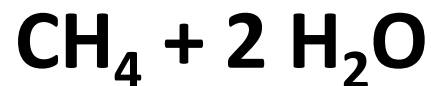

Hydrogen Conditioning
(increasing volumetric energy density)

Chemical Conditioning
(hydrogen bounded at another molecule)

- 👍 Easy handling in given infrastructure
- 👍 Very high demand for pure methane
- 👍 Flexible use of methane in various applications
- 👎 High energy demand for dehydrogenation
- 👎 Uncertain availability and high cost for green CO₂
- 👎 Climate impact due to methane leakage

Methane
($\text{CO}_2 + 4\text{H}_2 \rightleftharpoons \text{CH}_4 + 2\text{H}_2\text{O}$)

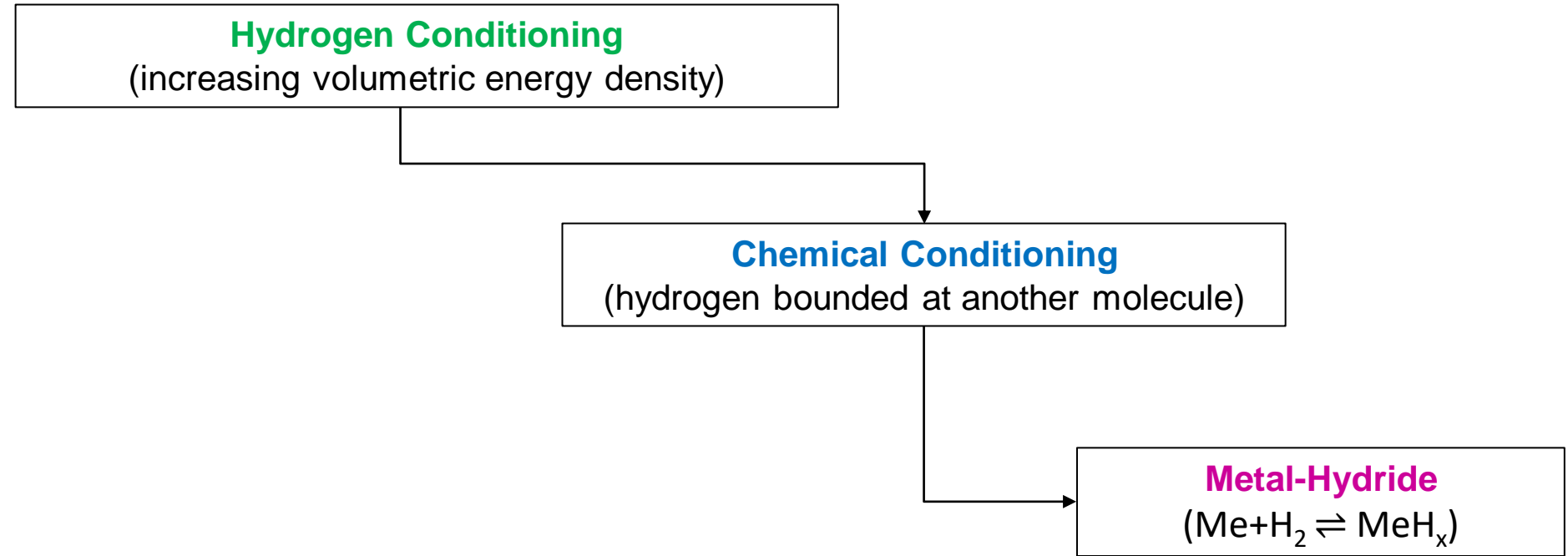

Metal hydride loaded with hydrogen

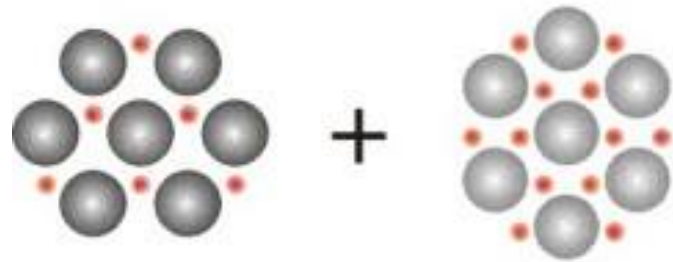

Hydrid I

Hydrid II

Hydrogen release from metal-hydride

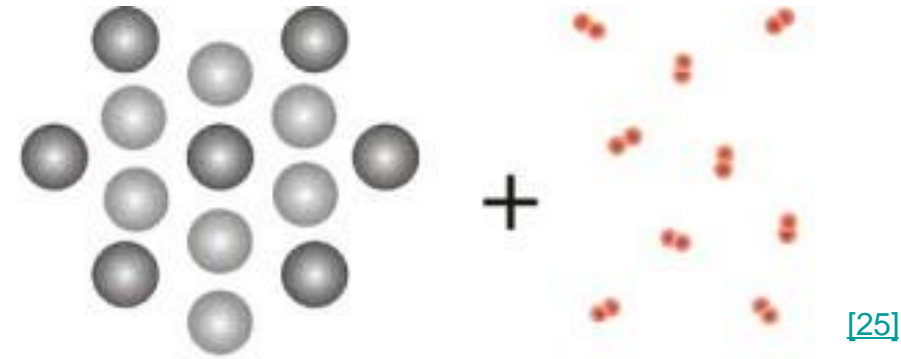

**Stabile
Verbindung**

Wasserstoff

[25]



[25]

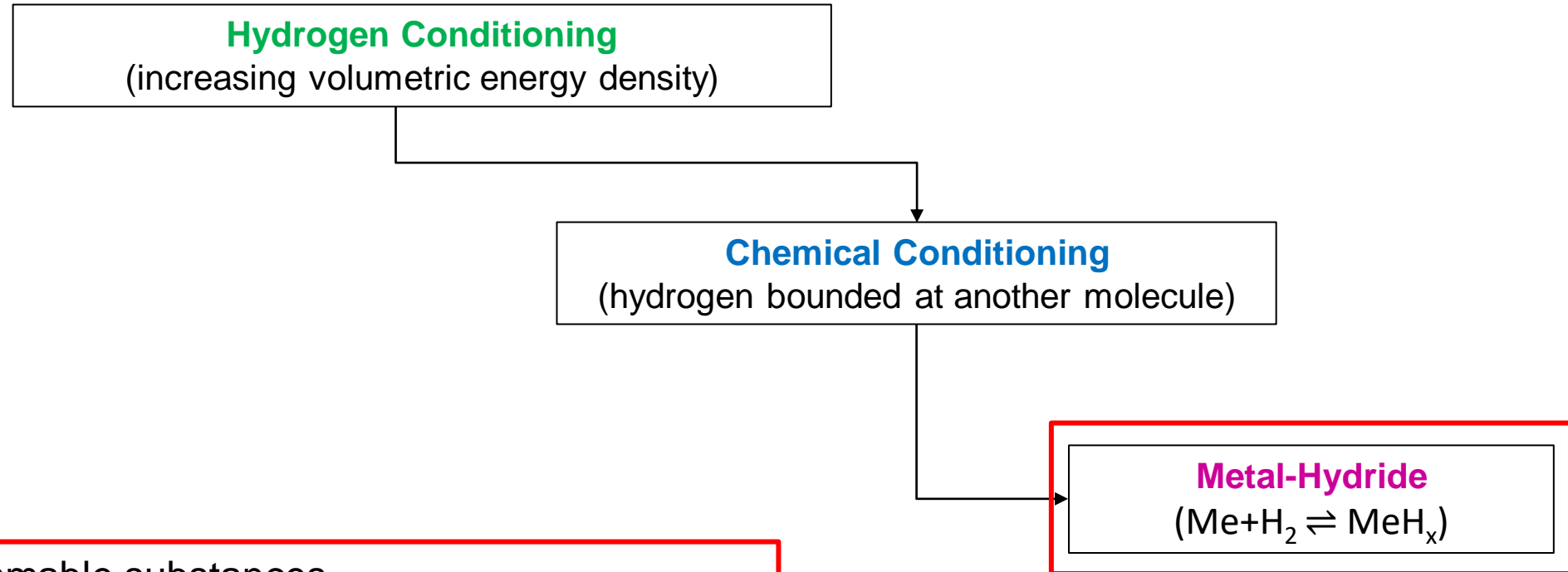

- 👍 No hazardous or flammable substances
- 👍 Very high volumetric energy density
- 👍 Long-term safe hydrogen storage at ambient conditions
- 👎 High weight and material requirement
- 👎 High technical effort for loading & unloading
- 👎 High energy demand for hydrogen recovery

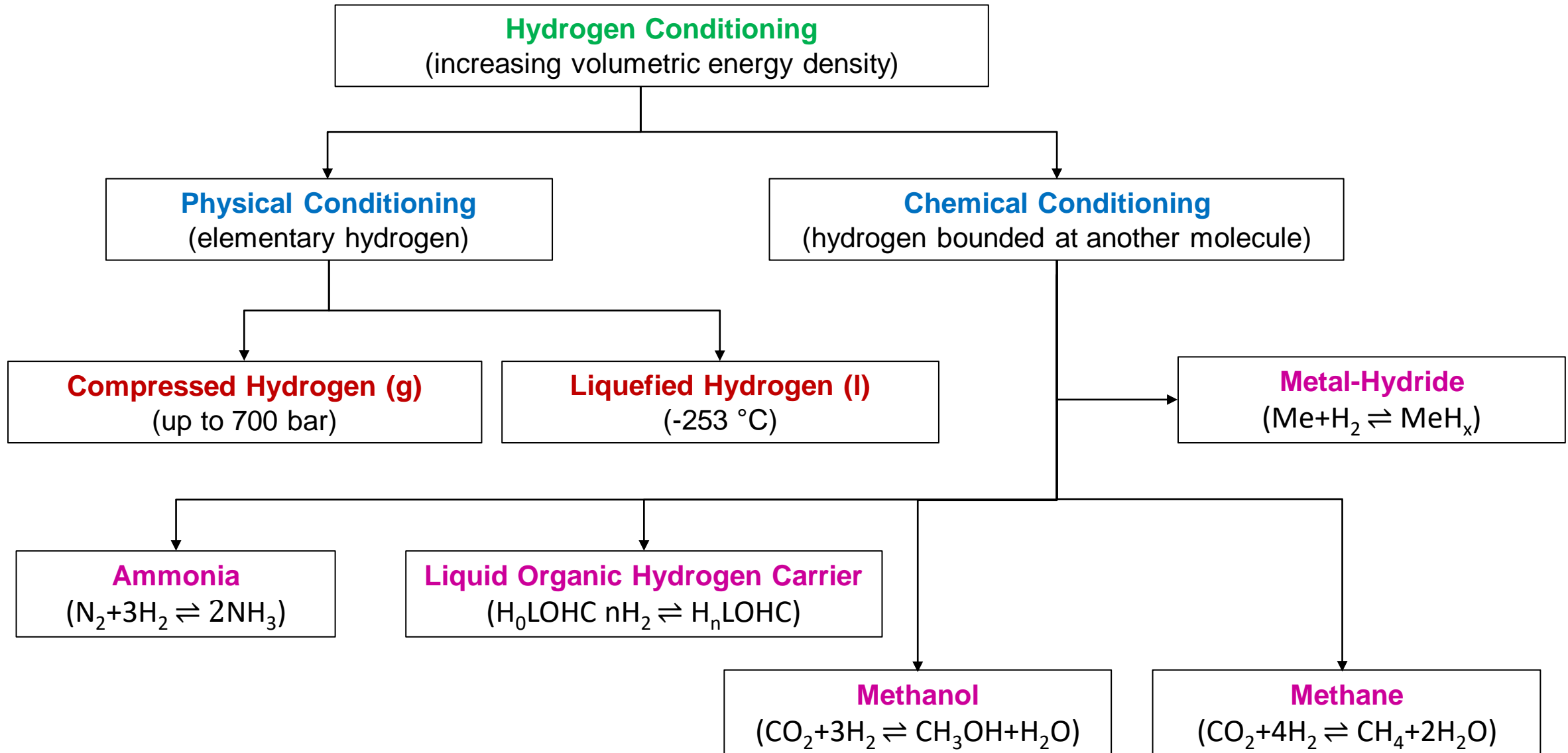

Energy supply chains based on hydrogen

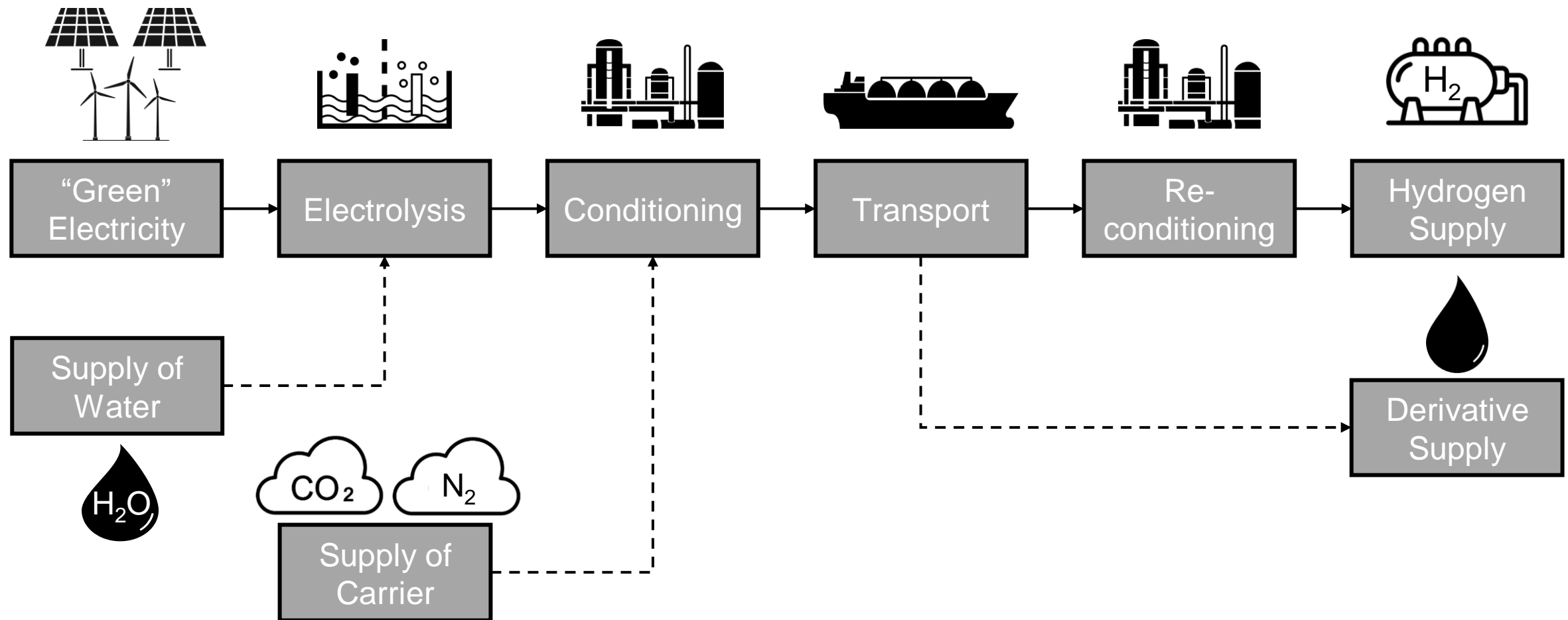

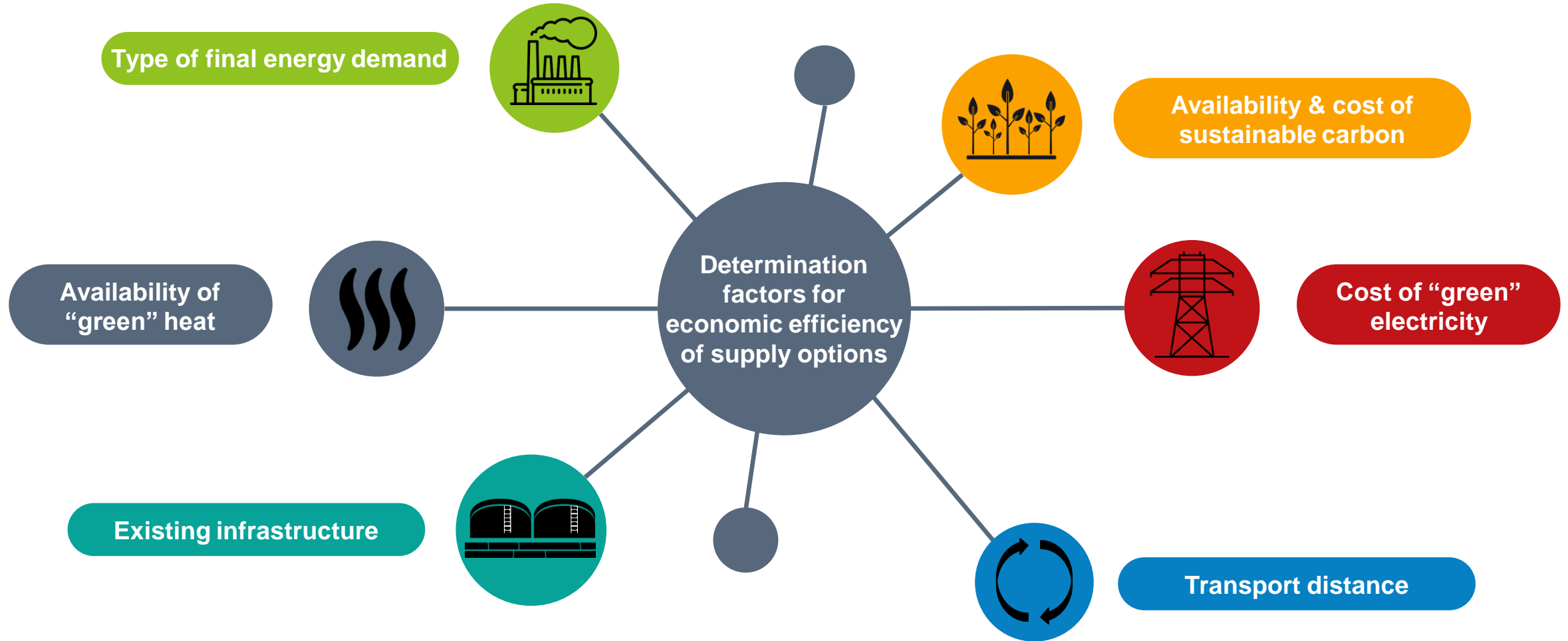

- ❖ Due to the limitations in electricity transportation (inflexible infrastructure, large-scale storage), most likely the international transport of “green” molecules will, like the trade of fossil fuel energy today, play an important role within a defossilized energy system.
- ❖ “Green” molecules can be transported via ships and pipelines; both options characterized by supplementing pros and cons are needed. Besides the typically “cheap” transport of “green” molecules by pipeline, ship-based transport of these molecules is likely to gain relevance due to its high flexibility and the longer distances to overcome under commercial conditions.
- ❖ Hydrogen as a “green” gas is characterized by a low gravimetric and a low volumetric density making a ship transport economically challenging. Thus, options to transform hydrogen into a another gas or into a liquid produced allow for more promising material characteristics related to a cost-efficient ship transport.
- ❖ All forms of such a hydrogen transformation into derivatives are associated with specific advantages and disadvantages. So far, especially the hydrogen derivatives ammonia, methanol and synthetic natural gas (SNG) are particularly promising for the transportation of “green” molecules due to existing technological solutions.
- ❖ But the economic advantage of a specific derivate is additionally determined by the requirements of the final customer.

Webinar Series
Hydrogen and Hydrogen Derivates - Possibilities and Constraints

10.01.2024

The significance of hydrogen derivates
Part 3 - Market demands

Fabian Carels, Martin Kaltschmitt

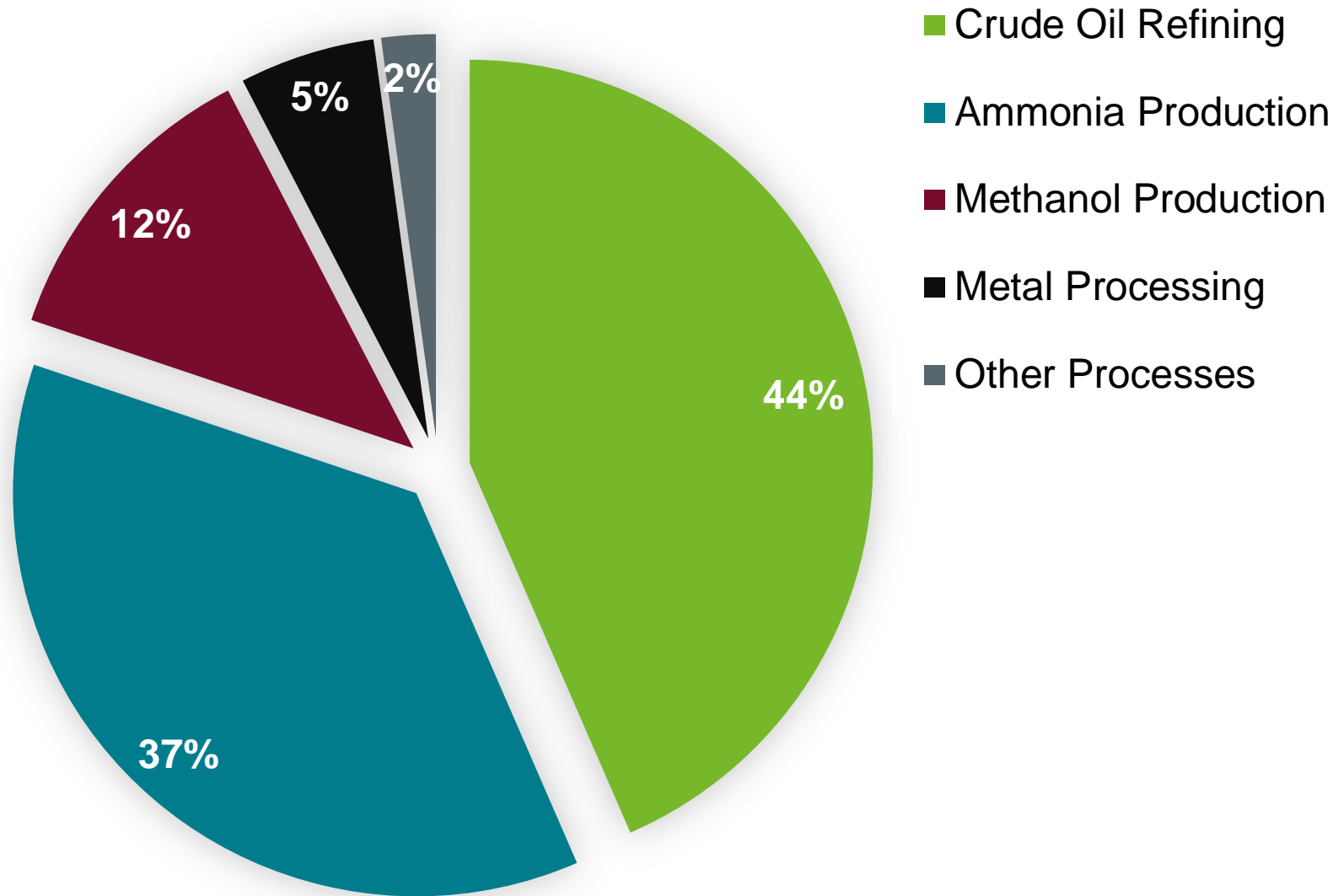

- Current global hydrogen demand of 75 Mt_{H₂}/a and additional 45 Mt_{H₂-Mix}/a (synthesis gas)
- H₂ almost entirely used in various industrial applications
- Largest share of demand covered by fossil based hydrogen (mainly from Steam Methane Reforming)

Potential markets for hydrogen in the future

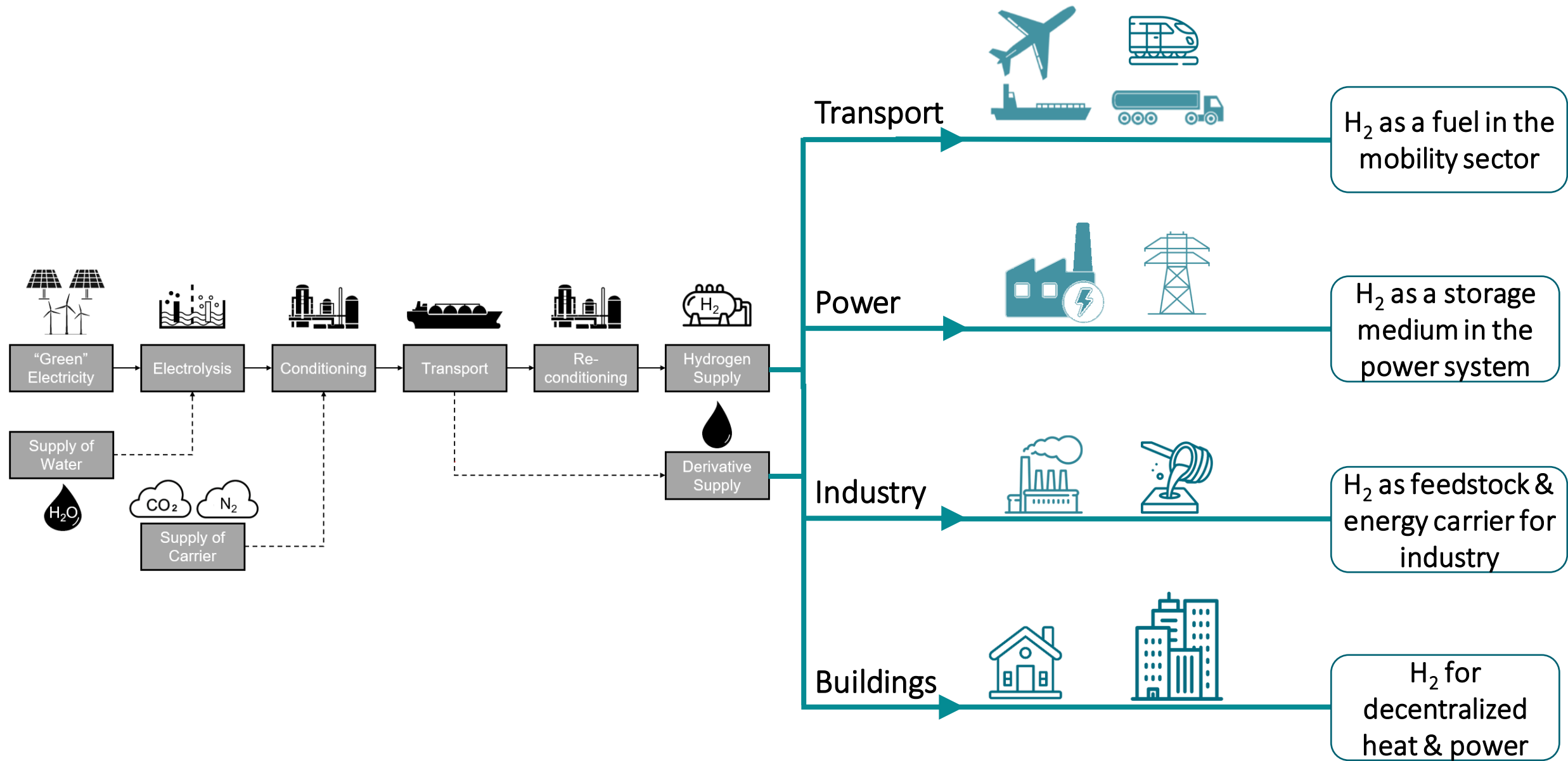

Potential use cases for hydrogen in the future – Industry

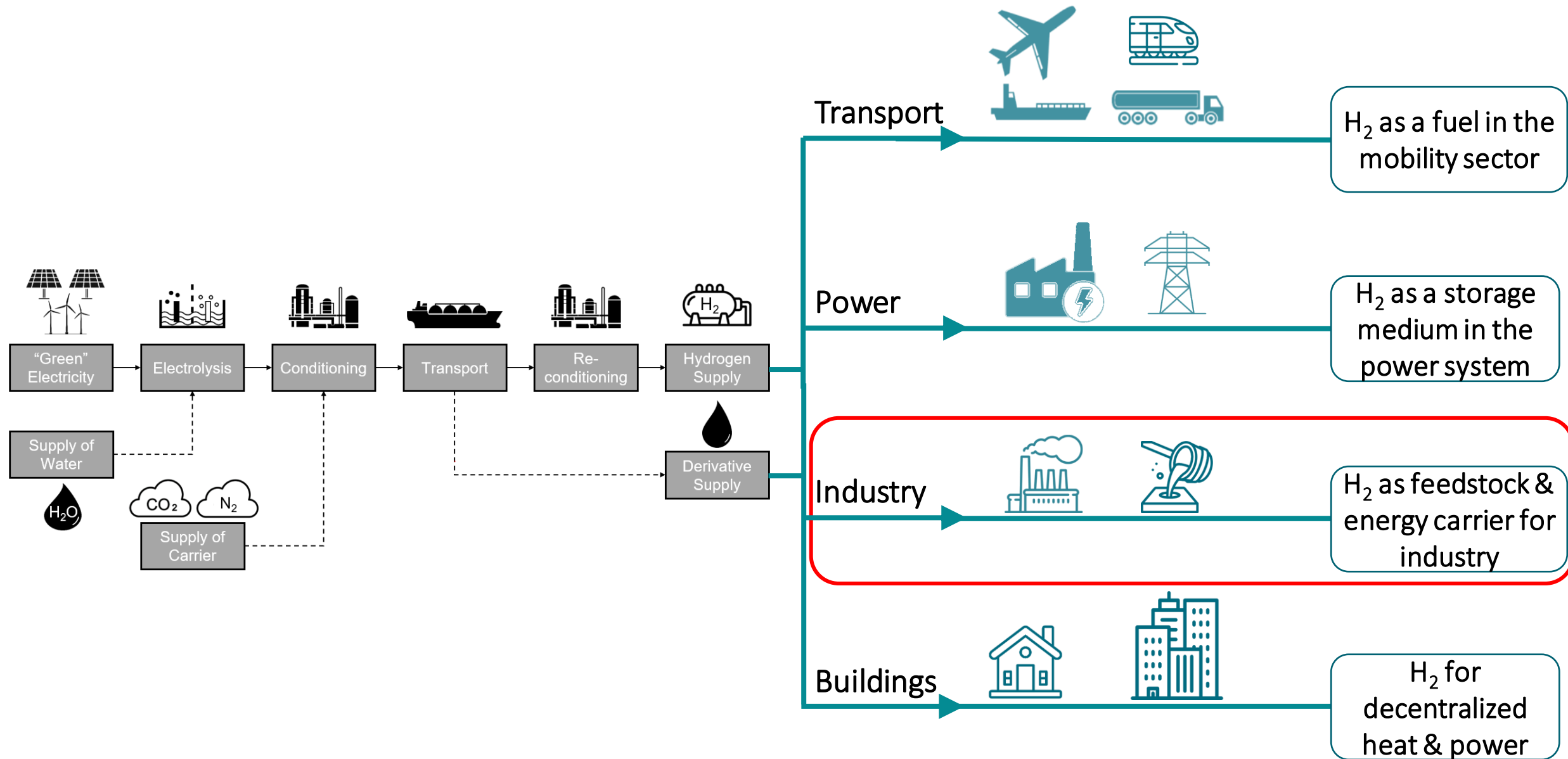

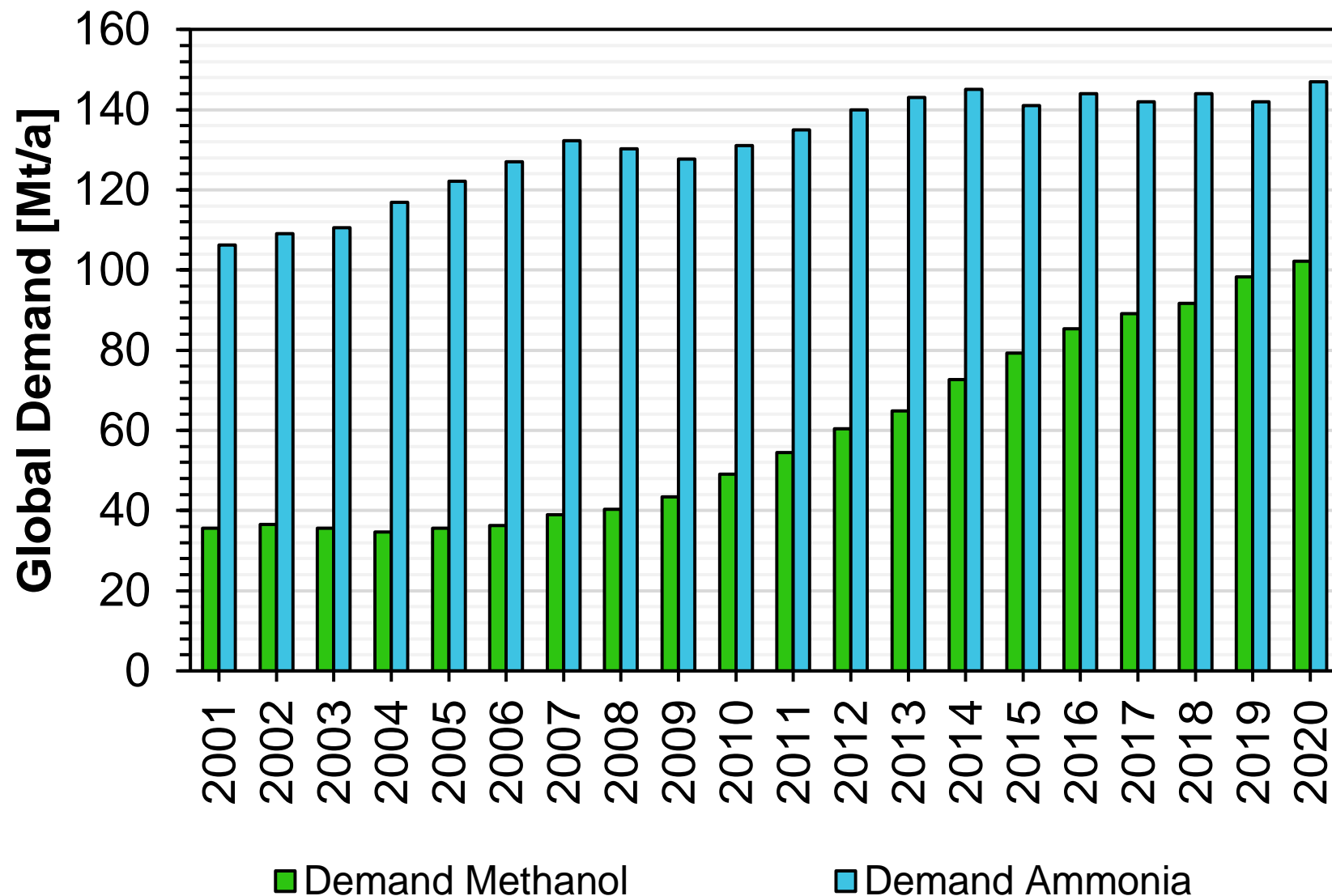

Ammonia > 150 Mt/a₂₀₂₀

- Slight growth in demand (12% in last decade)
- Increase broadly in line with rise in population

Methanol > 100 Mt/a₂₀₂₀

- Demand doubled within the last decade
- China's methanol economy is the main driver of this growth
- Very diverse use; mainly through chemical downstream processing

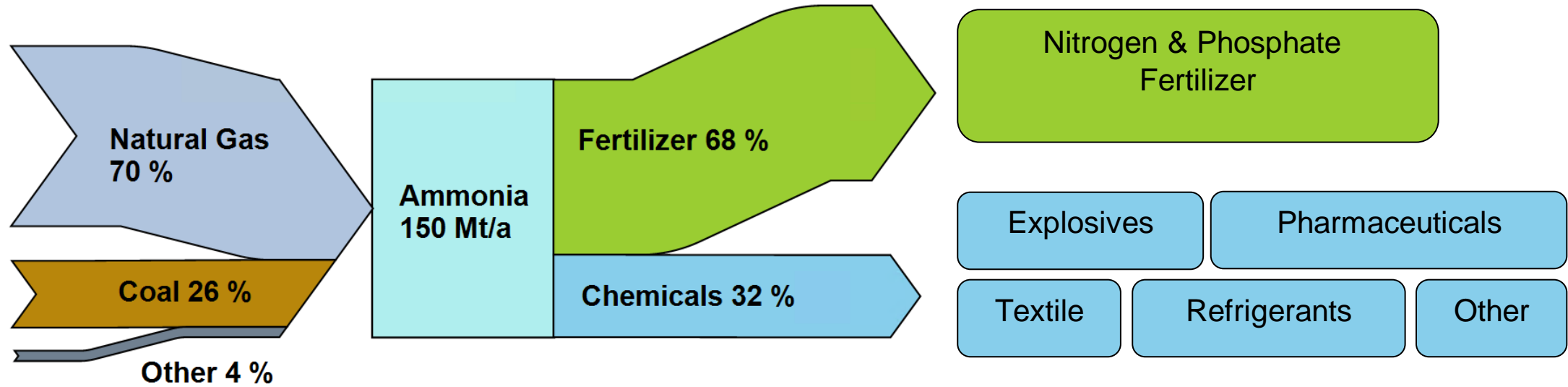

Current and announced projects for near-zero-emission ammonia production

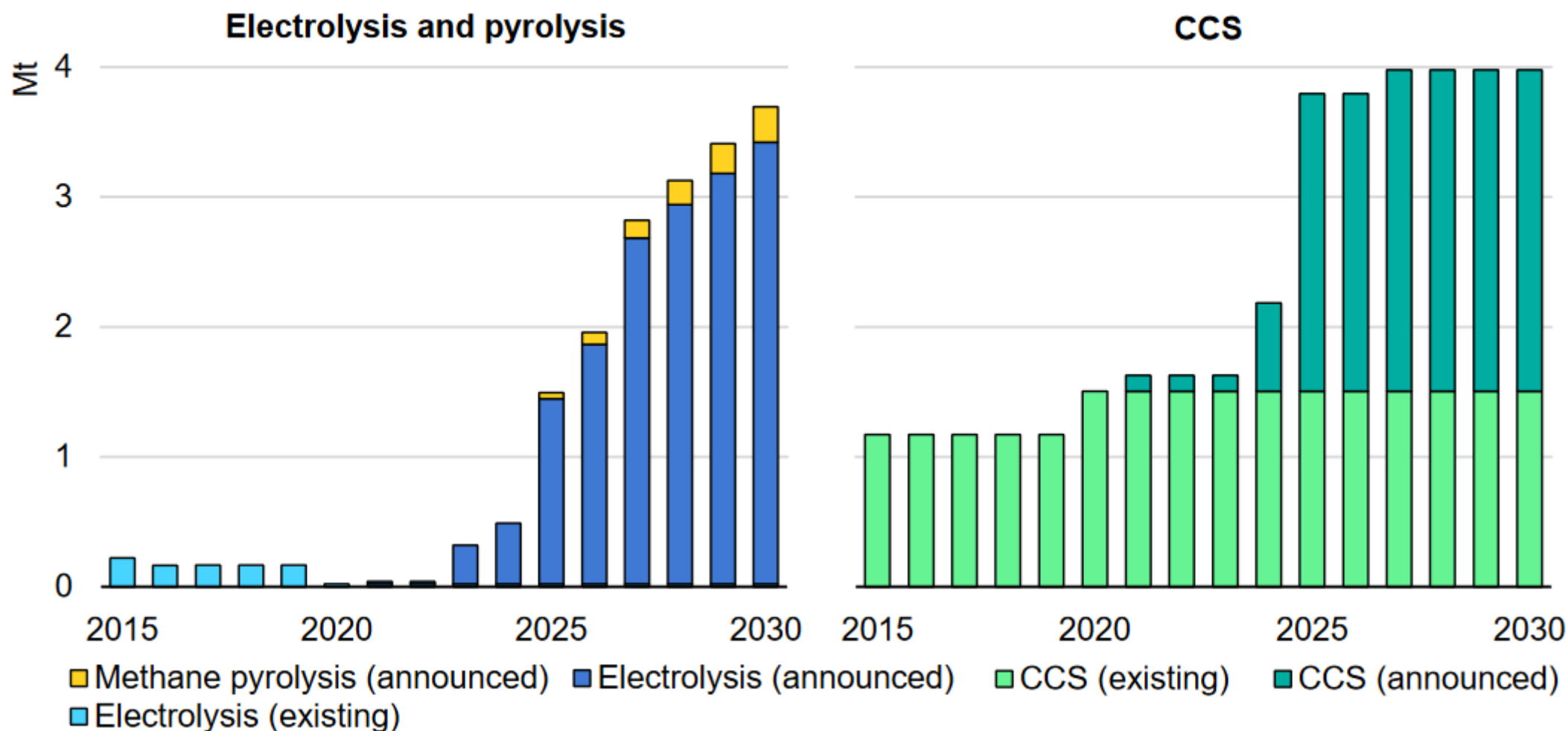

Global Ammonia Supply and Demand, 2020–2030, Thousand Tons

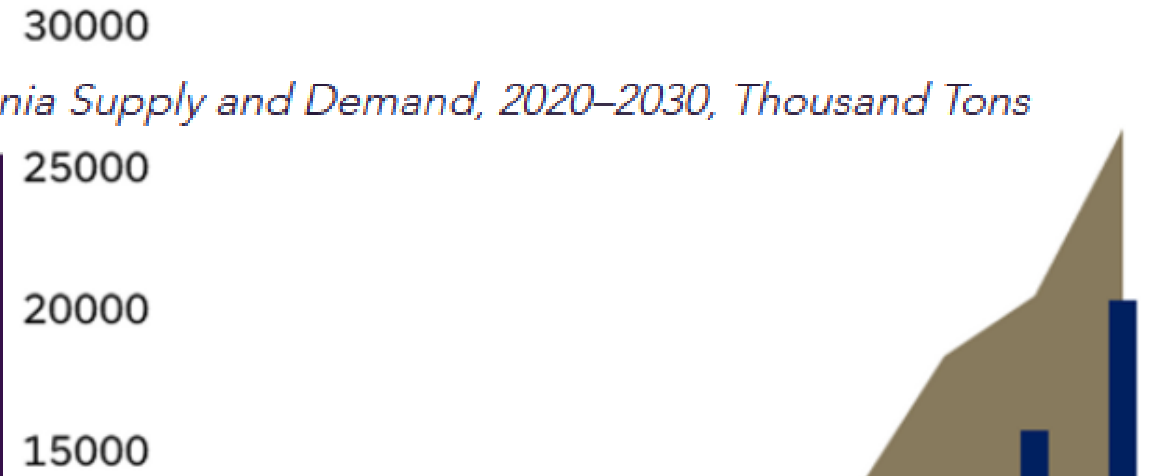

U.S. Green Ammonia Market

Size, by Technology, 2020 - 2030 (USD Million)

\$3.8M \$9.2M

2020 2021 2022 2023 2024 2025 2026 2027 2028 2029 2030

● Solid Oxide Electrolysis ● Proton Exchange Membrane
● Alkaline Water Electrolysis

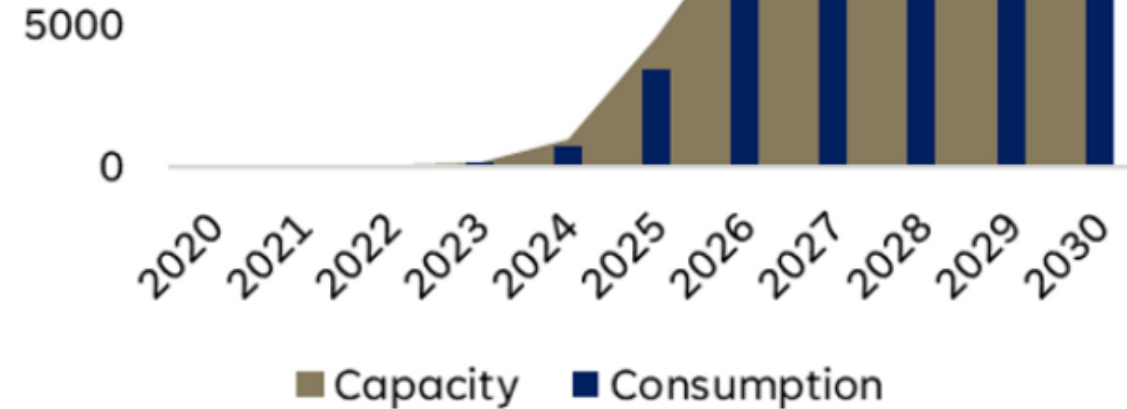
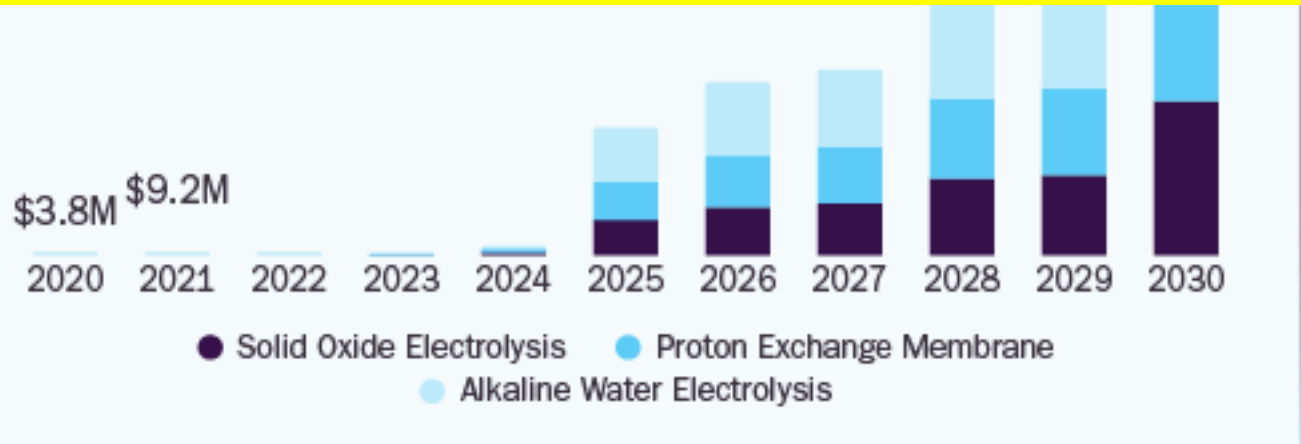

■ Capacity ■ Consumption

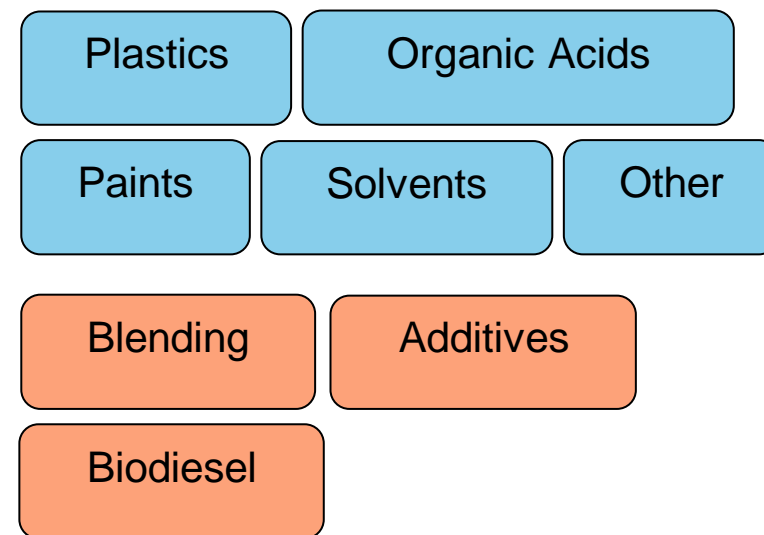
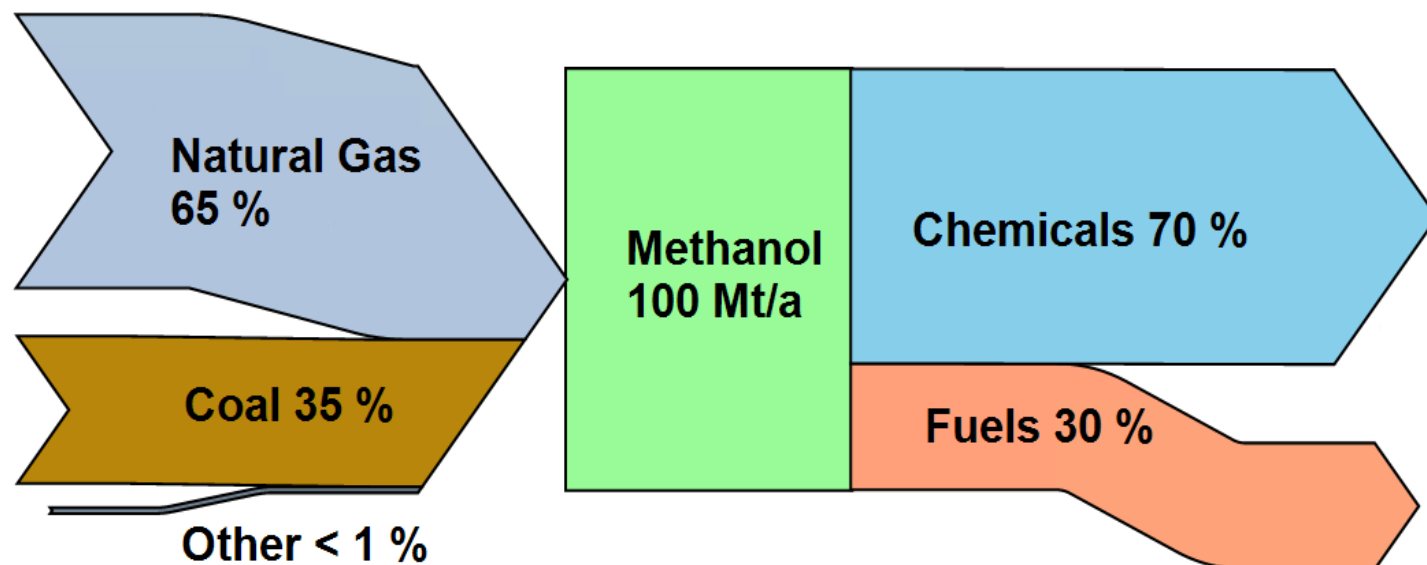

Projections for production of renewable methanol

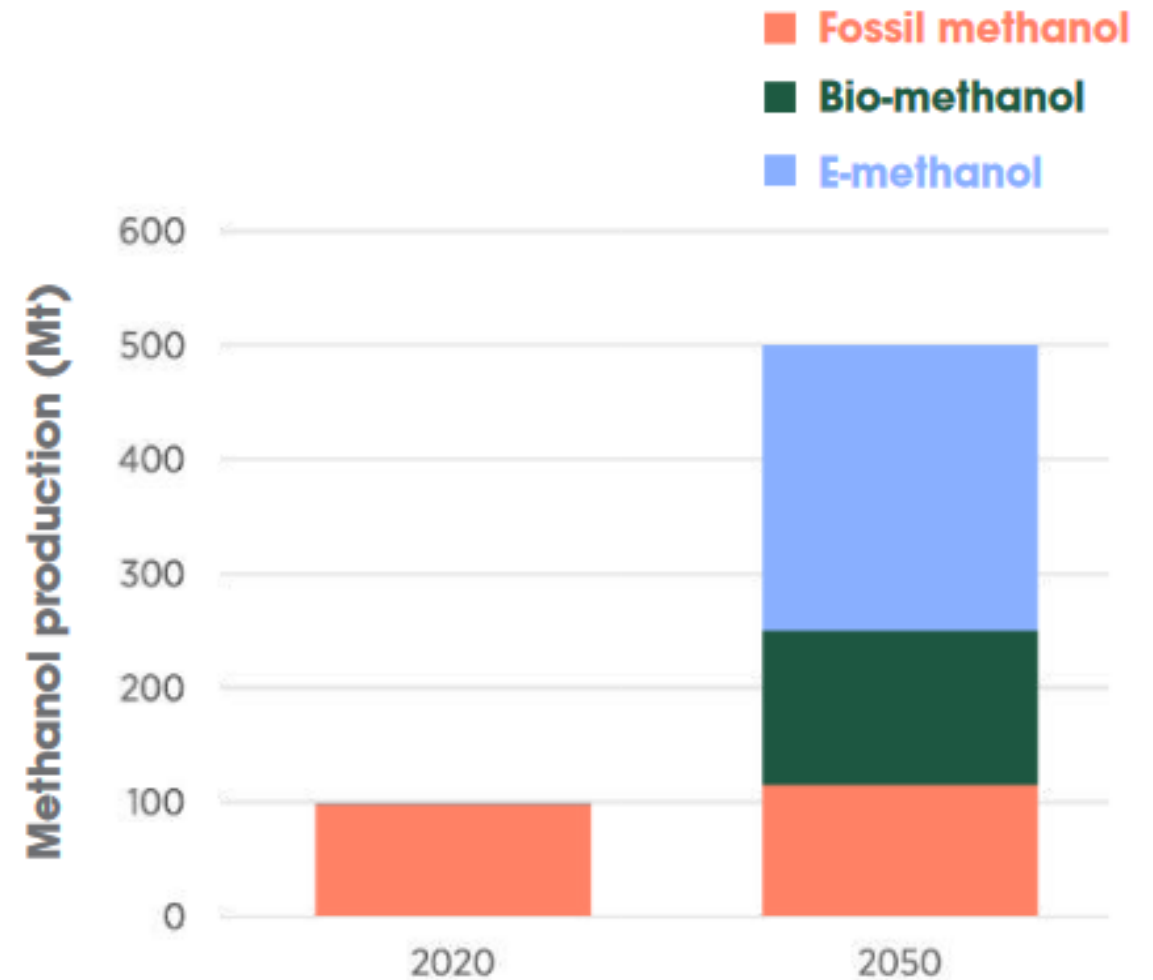
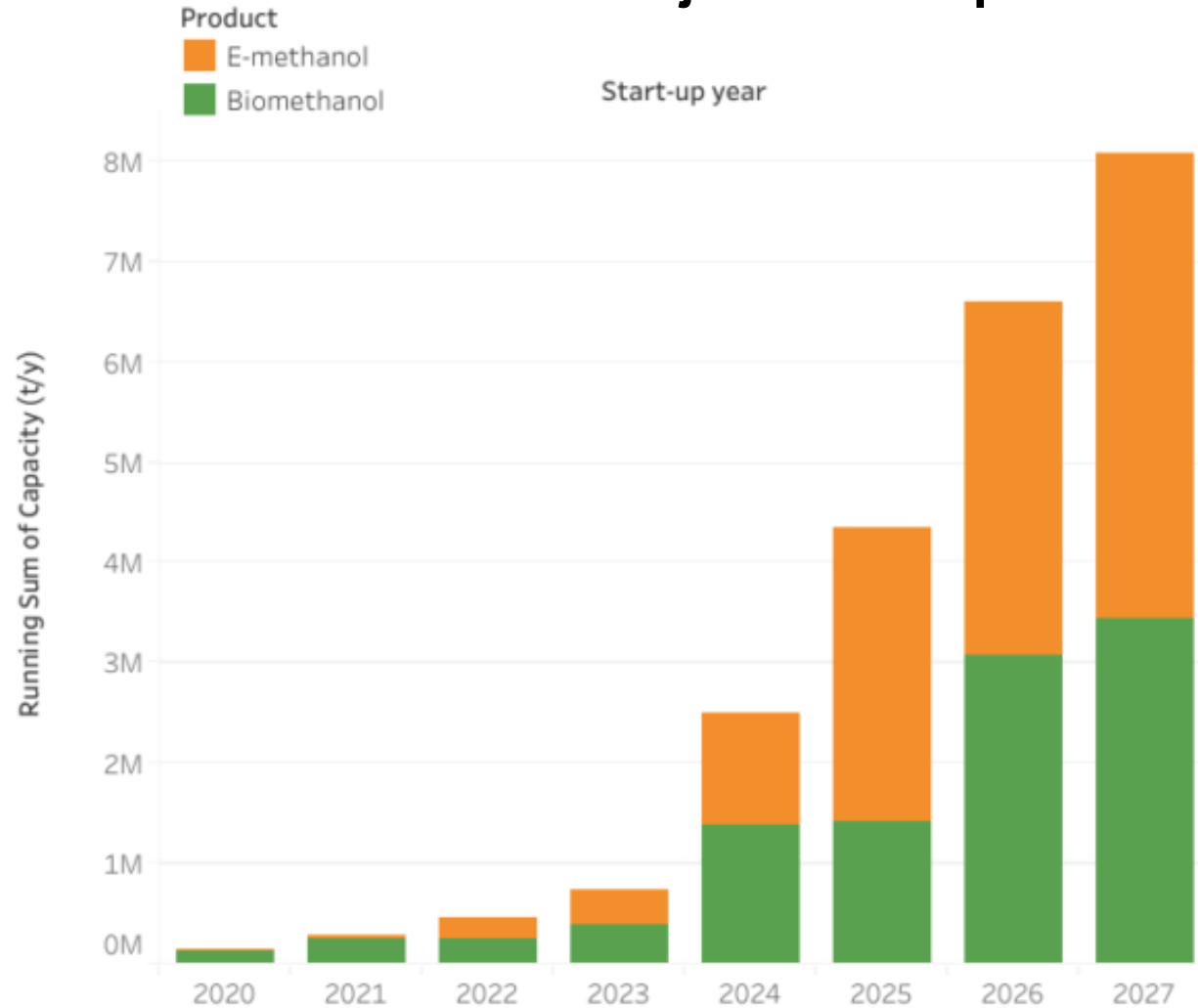

Source : Methanol Institute Renewable Methanol Database of Current/Announced Projects



Green Methanol has already a substantial market and will gain even higher market volumes due to newly emerging additional markets.

Potential use cases for hydrogen – Transport

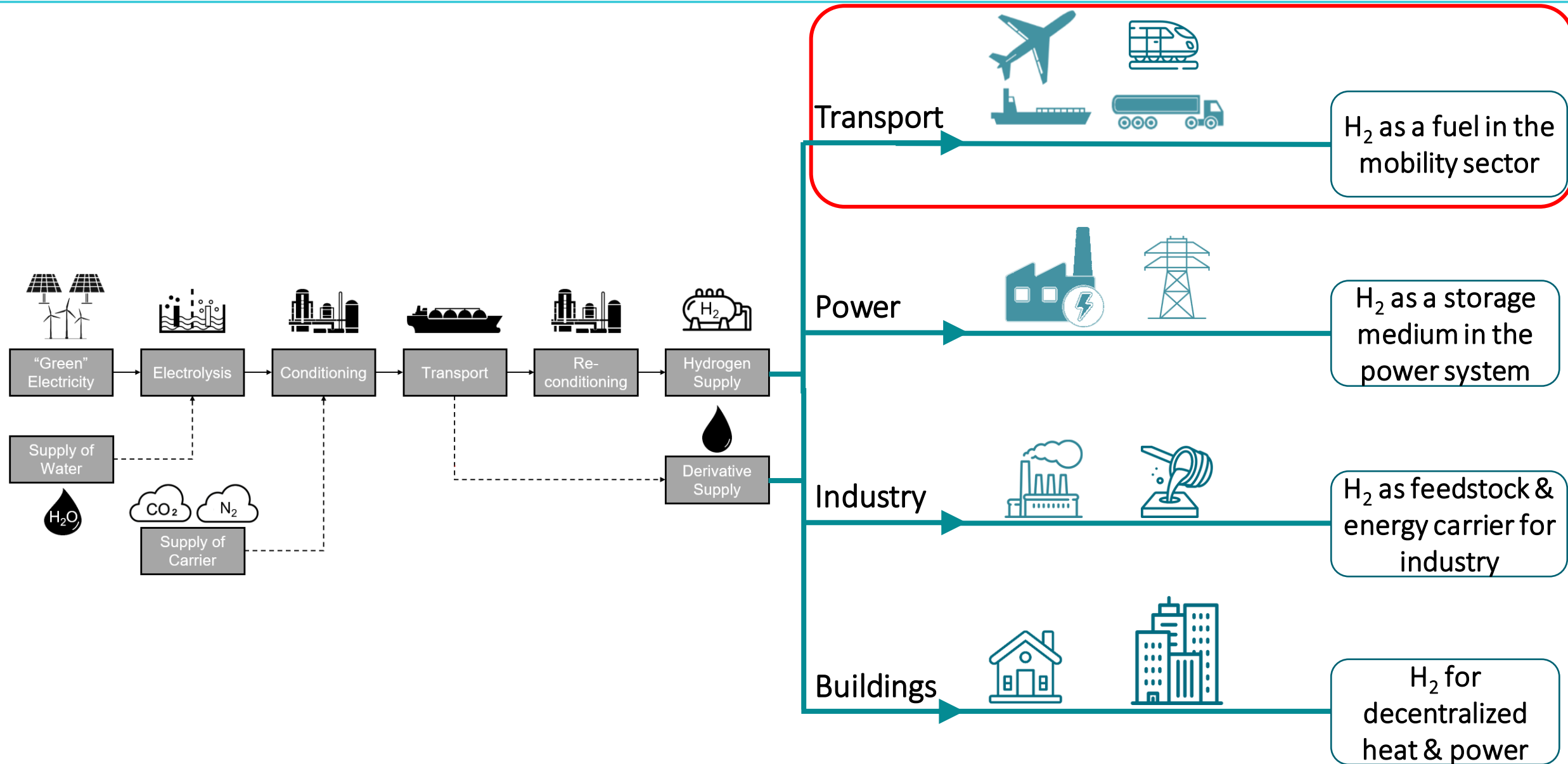

- ❖ The Renewable Energy Directive ("RED") sets binding targets for the Member States that must be achieved by 2030 → Each member state must implement these targets in its national legislation
- ❖ In future, “RED III” (2023/2413) introduces sub-quota(s) for RFNBO in transport sector to be achieved by 2030:
 - 1.0 % of final energy in whole transport sector
 - 1.2 % of final energy in maritime sector*
- ❖ RFNBO can generally be used in the entire transport sector
- ❖ For target “29 % share of renewable energy”: RFNBO incentivised by accounting factors (but: other fuel options as well!)

Possible overall targets	GHG-Quota	Share of Renewable Energies
Target to reach (%)	14.5	29
Sub-Quota for RFNBO (% of final energy consumption)	1	1
Accounting factor (-)	2	2
Accounting factor for RFNBO in maritime or aviation sector (-)	1.5	1.5

* Non-Mandatory; Member states shall “endeavour to ensure“ that the share of RFNBO supplied to the maritime sector is at least 1.2 % in 2030 (Directive 2023/2413 („RED III“))

Battery costs

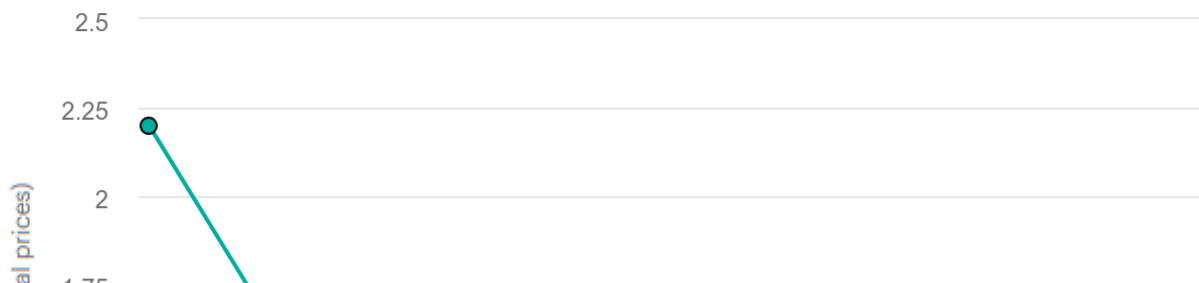

Worldwide sales of battery-electric vehicles

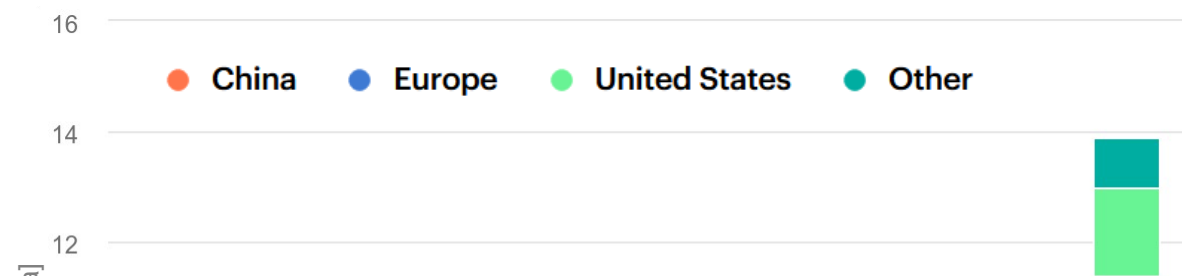

Due to latest technology developments in the field of battery-electric passenger cars and the dynamic market growth on a global scale it is most likely from a current point of view that hydrogen-powered passenger cars will not play a key role in ground-based transportation in the future.

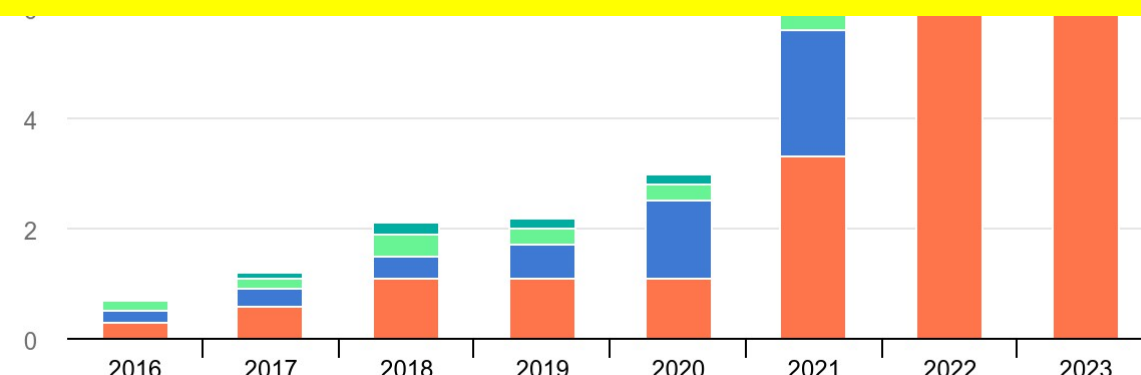
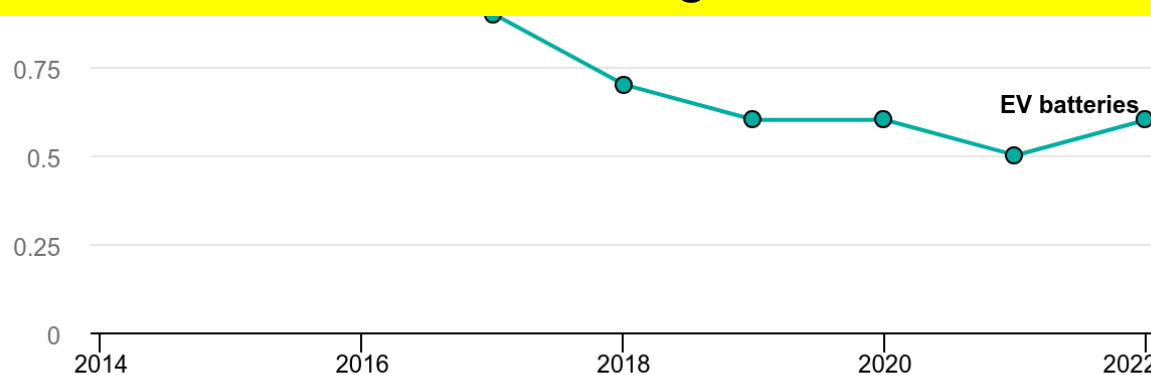

Hydrogen-powered vehicles – Road transport

FINANCIAL TIMES

Northvolt in new sodium-ion battery breakthrough

Swedish start-up has developed an energy storage technology with no critical minerals including lithium which could minimise reliance on China

[26]

Autos & Transportation | Sustainable & EV Supply Chain

VW masters dry-coating battery process with potential to slash cell costs

Reuters

June 16, 2023 3:00 PM GMT+2 · Updated 7 months ago

🔖 Aa ⏪

[27]

[28]

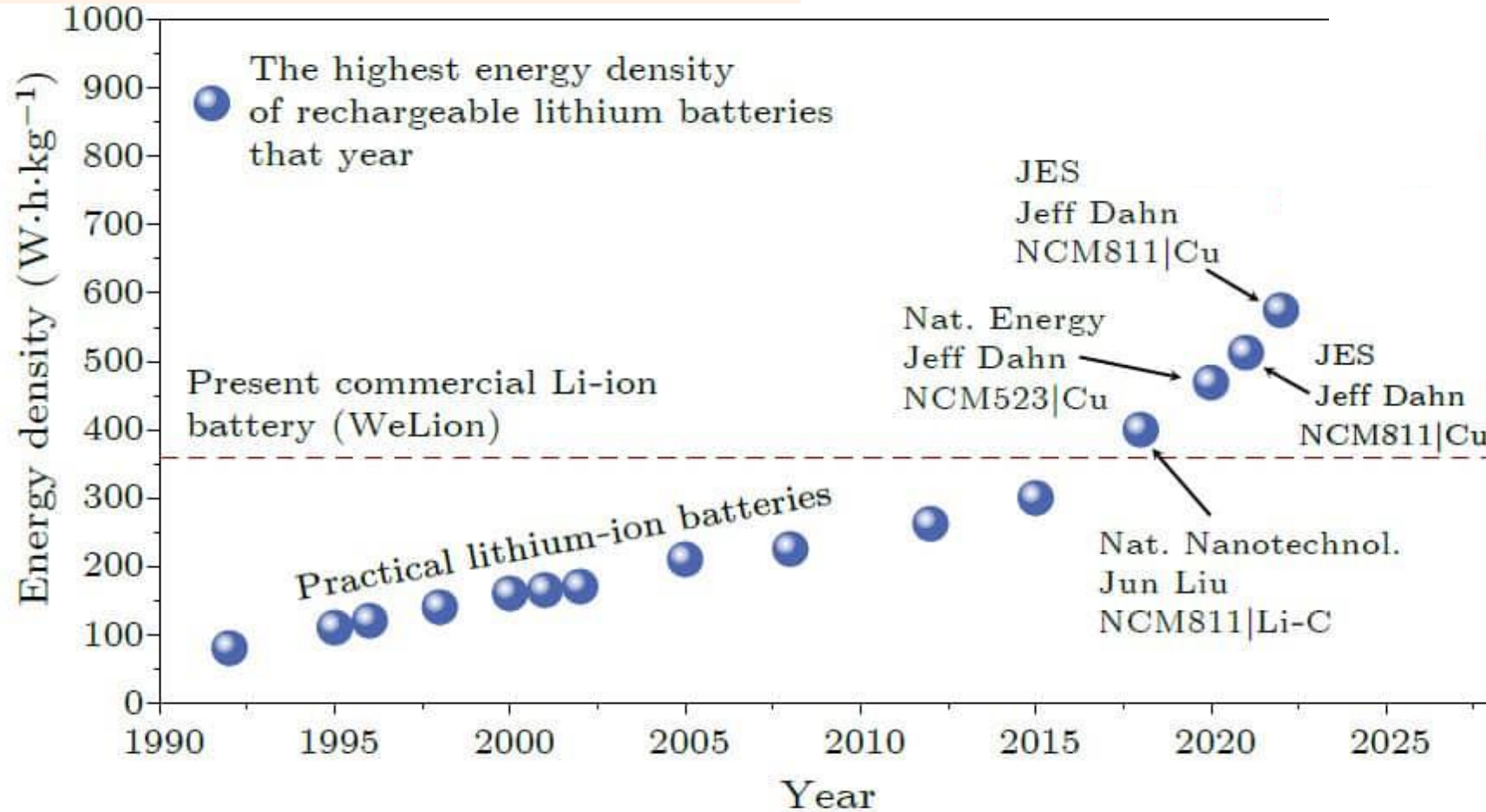

Mercedes-Benz Trucks celebrates world premiere of the battery electric long-haul truck eActros 600

Forecasted sales of heavy duty vehicles (> 12 t) in Europe

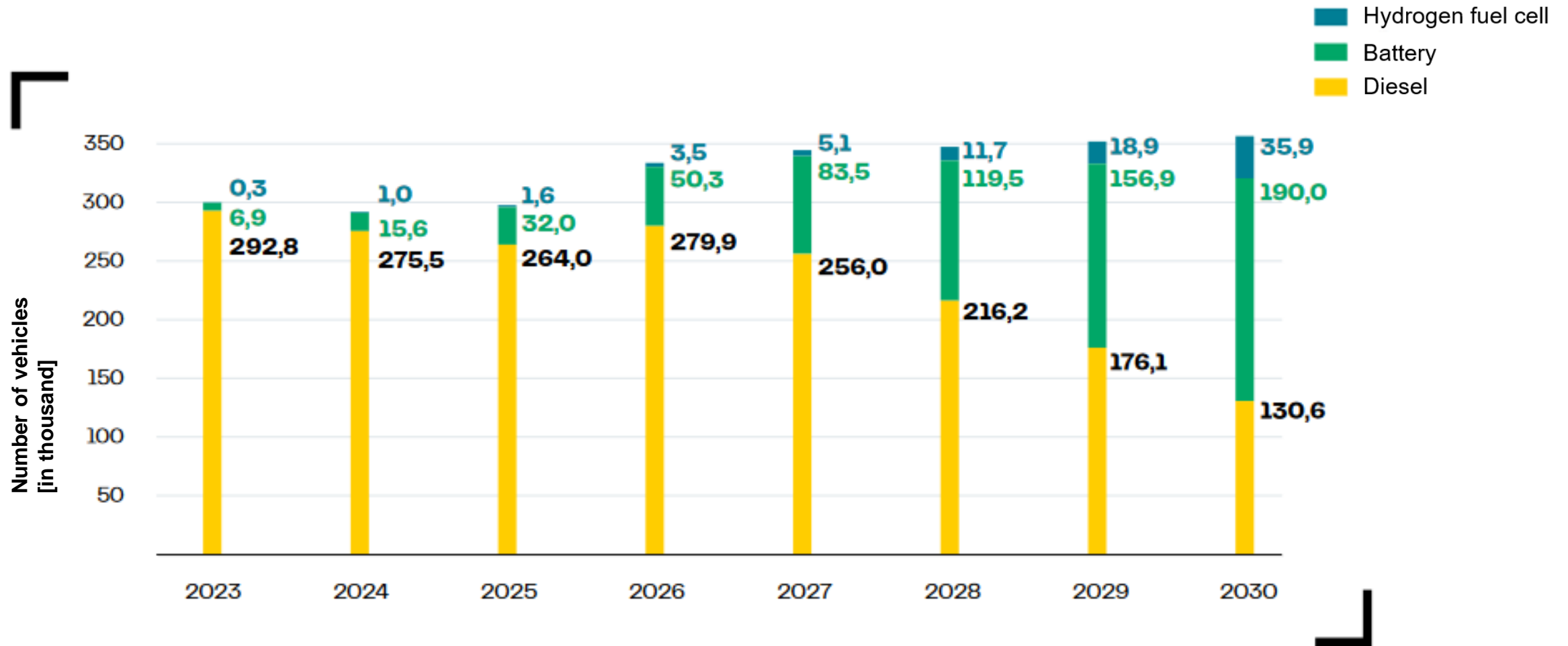

Forecasted demand of hydrogen and hydrogen derivatives in road transport

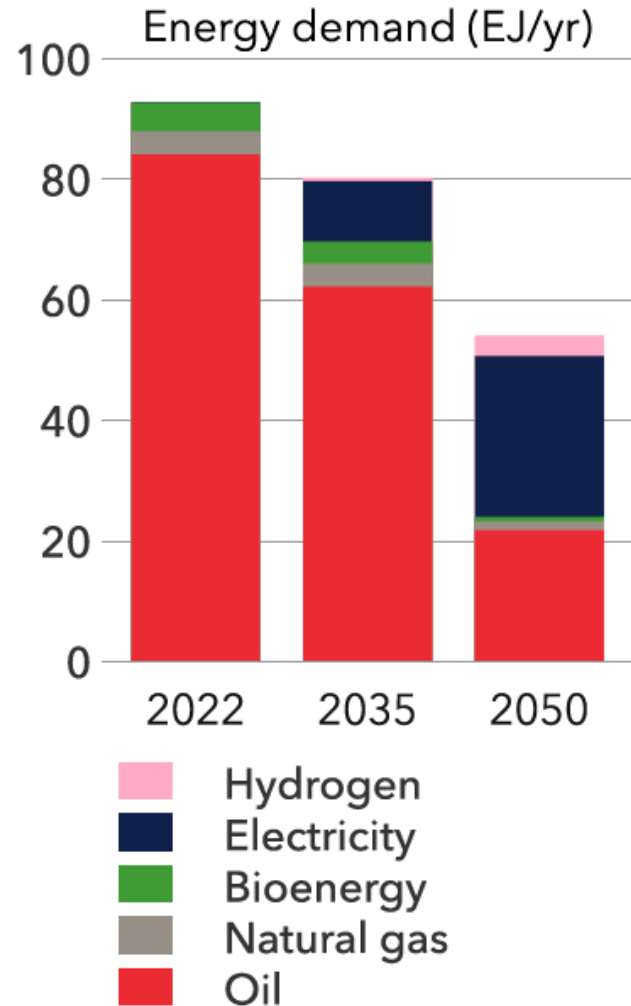

In the defossilized road transport of the future, battery electric vehicles will in all likelihood be predominantly used. Hydrogen and hydrogen derivatives will only be used in niche applications.



The FuelEU maritime regulation will oblige vessels above 5 000 gross tonnes calling at European ports
(with exceptions such as fishing ships):

→ to reduce the greenhouse gas intensity of the energy used on board as follows

Annual average carbon intensity reduction compared to the average in 2020

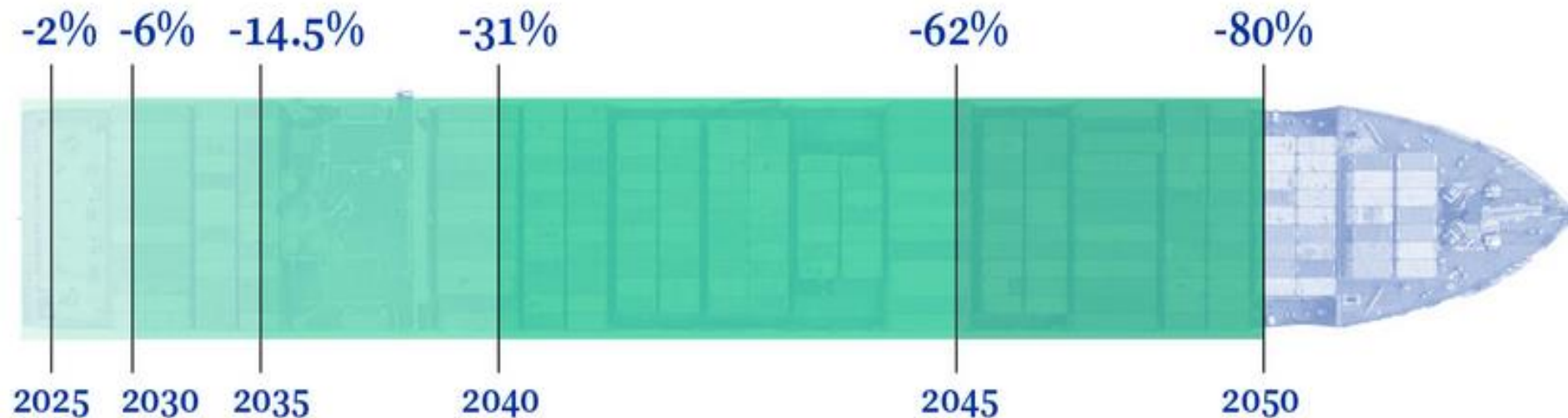

Wärtsilä solutions chosen for world's first methanol fuelled hybrid RoRo vessels

Wärtsilä Corporation, Press release 13 September 2023 at 10:00 UTC+2

Press releases

Maersk to deploy first large methanol-enabled vessel on Asia - Europe trade lane

07 December 2023

Ocean Transport Decarbonisation

Share



COSCO Shipping Energy picks methanol for six new tankers

[29]

[28]



[30]

Forecasted demand of hydrogen and hydrogen derivatives in maritime transport

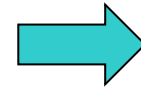
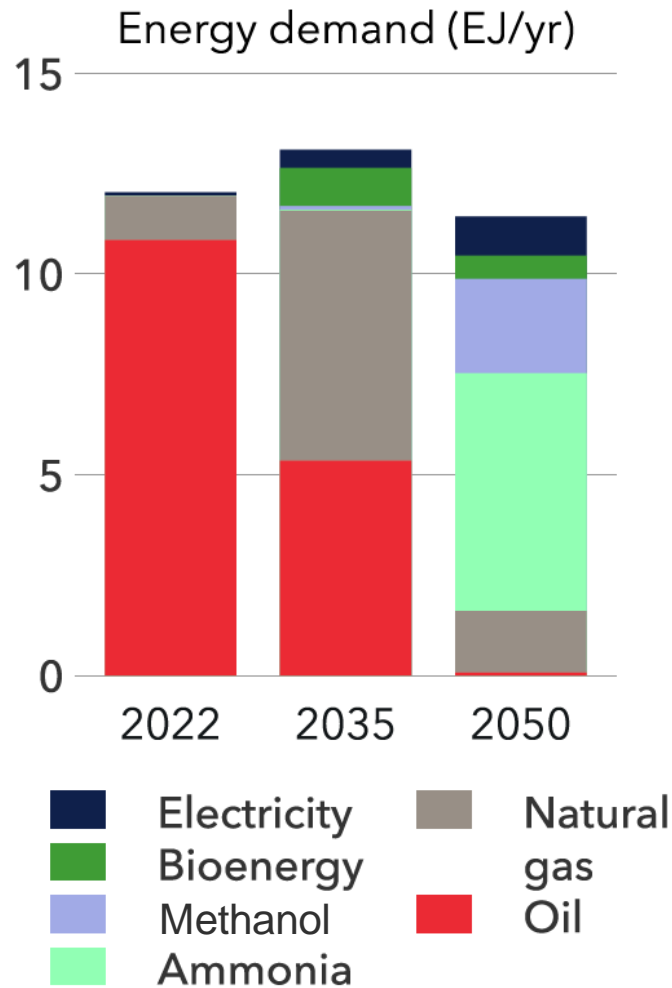

"Green" methanol and/or ammonia are expected to be the predominant renewable marine fuels in the future. The first developments in the market for converting propulsion systems to these fuels can already be seen today.

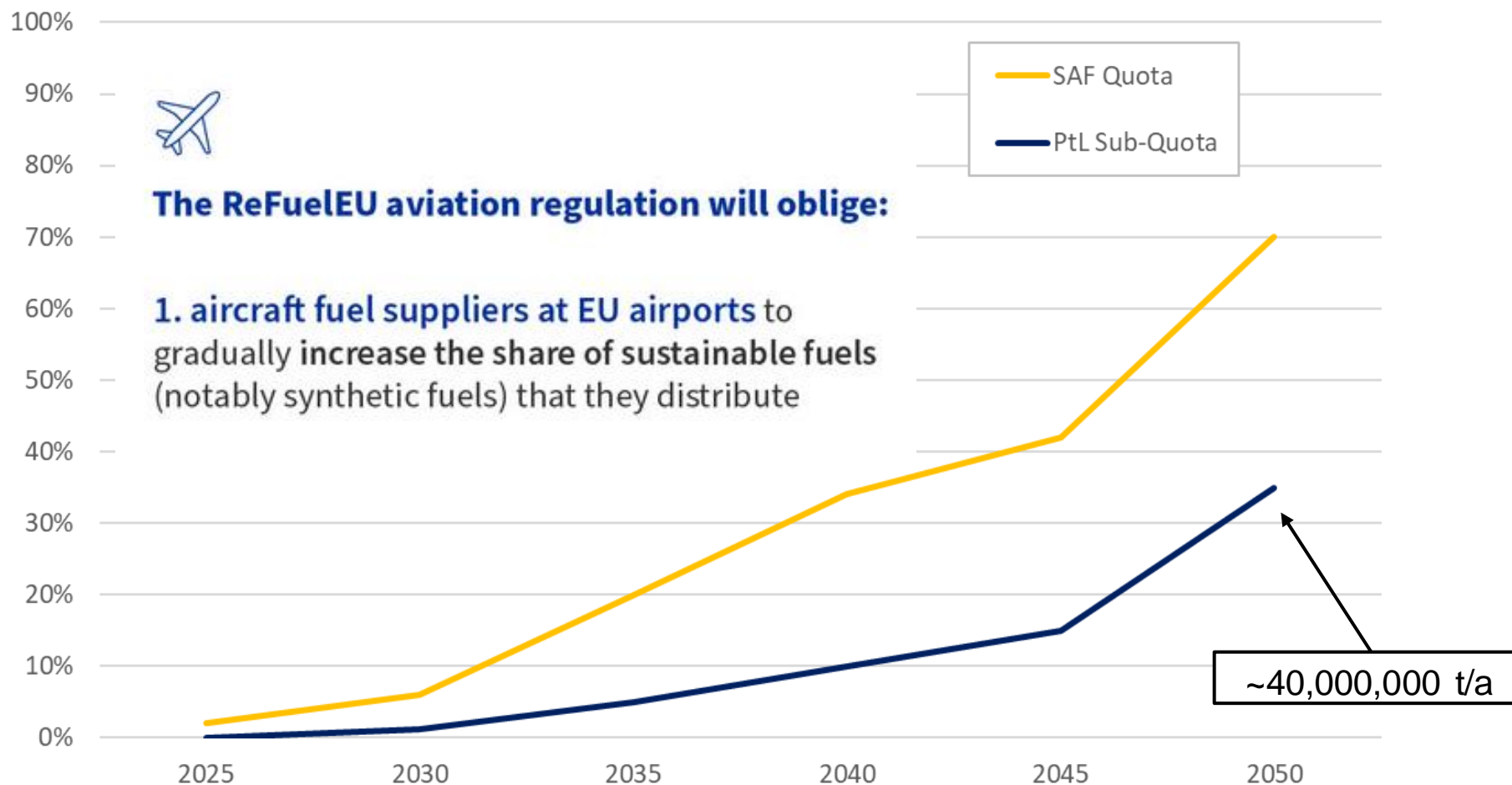

Biogenic or synthetic (PtL) kerosene is the only sustainable option for the foreseeable future to decarbonize aviation. This is especially true for medium- to long-haul flights where novel propulsion systems (e.g., based on liquid hydrogen) are technologically too challenging.

Global → Focus on biogenic kerosene

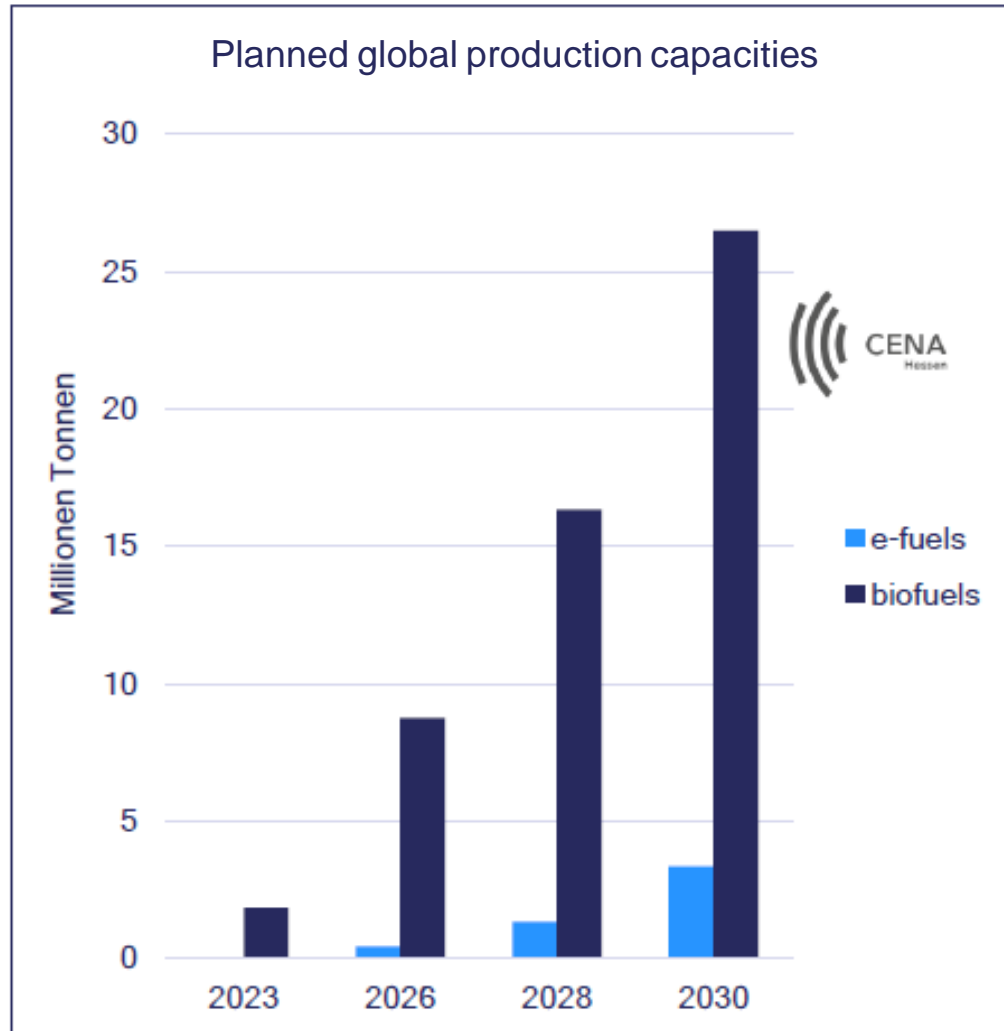

Germany → Focus on PtL kerosene

Announced PtL Produktion

- Berlin 15.000 t/a
- Köln no info
- Cottbus no info
- Dresden 10.000 t/a
- Freiberg no info
- Frankfurt 3.500 t/a
- Jülich lab-scale
- Karlsruhe no info
- Leuna 10.000 t/a
- Leipzig 70.000 t/a
- Steyerberg 2.400 t/a
- Stuttgart feasibility study

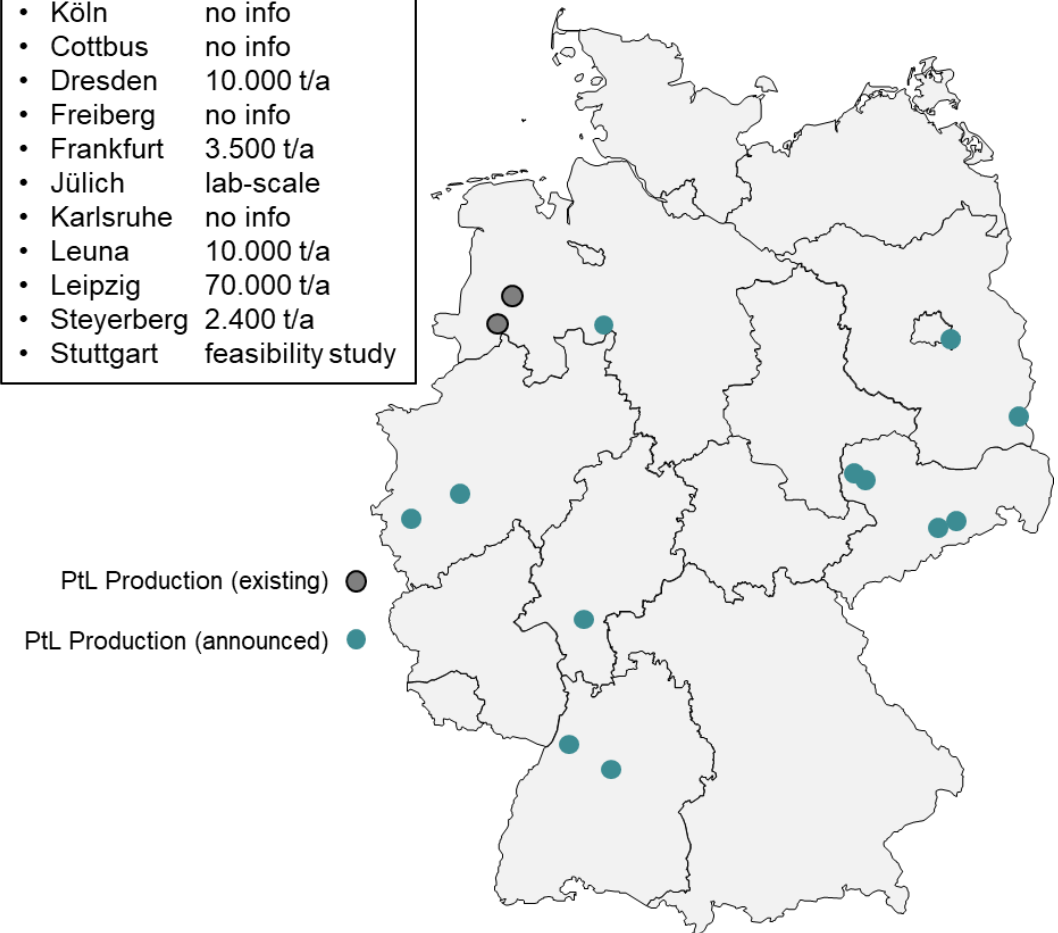

Forecasted demand of hydrogen and hydrogen derivatives in aviation

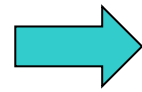
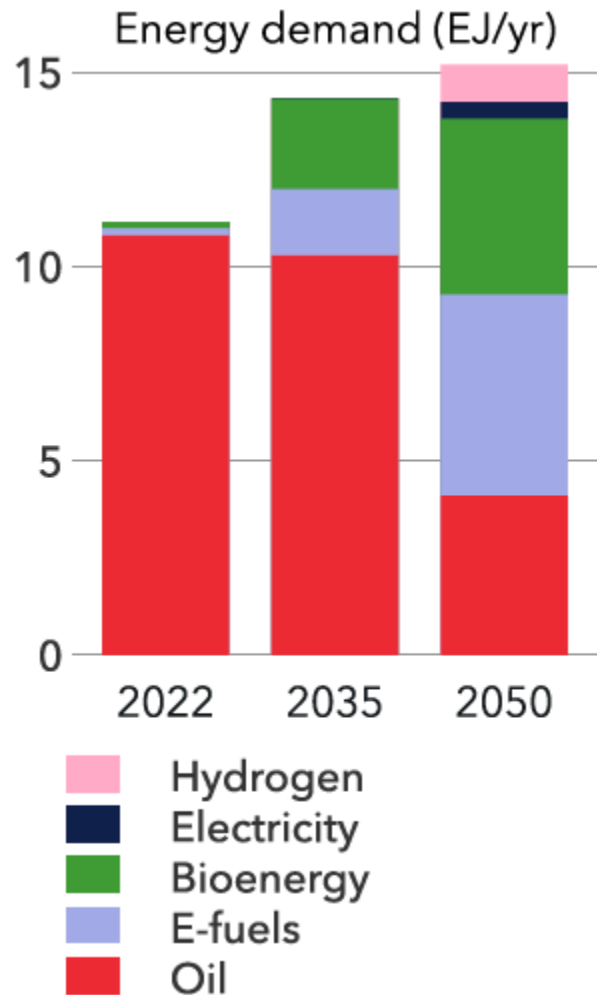

PtL kerosene (*E-fuel*) made from (green) hydrogen will play a pivotal role in the defossilization of aviation. It has almost identical properties to fossil. The emergence of an international market is therefore likely.

Potential use cases for hydrogen in the future – Heat for buildings

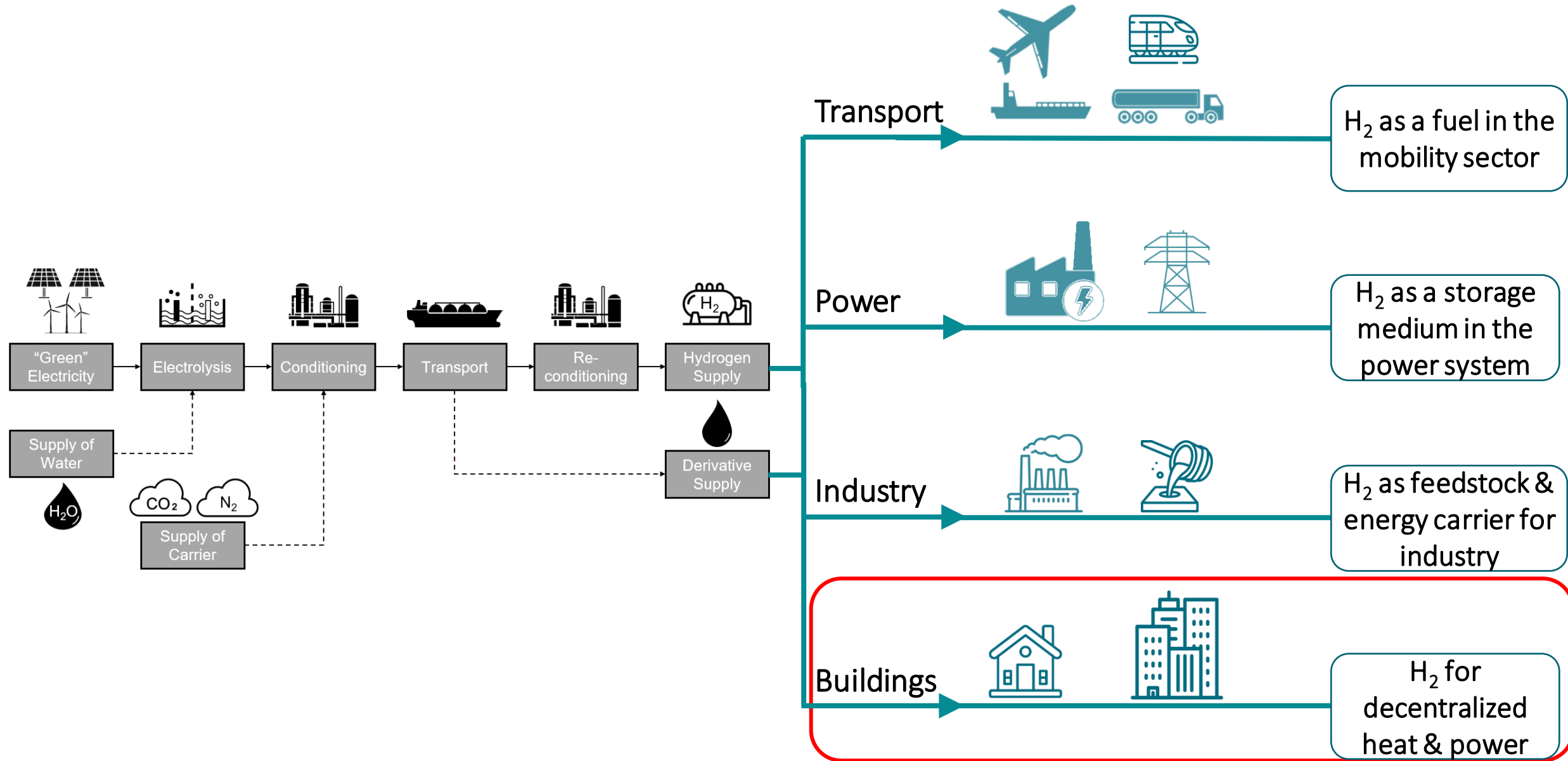

Der Wärmemarkt im Detail: Endenergieverbrauch nach Anwendungsbereichen und Sektoren

Warmwasser 138 Mrd. kWh

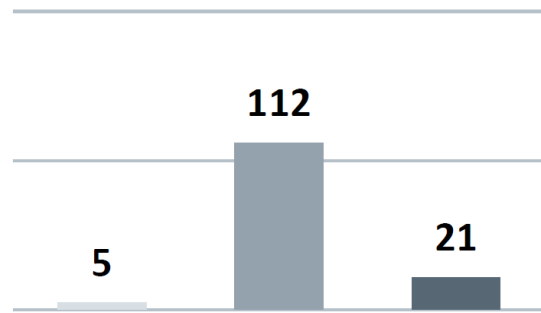

Prozesswärme 598 Mrd. kWh

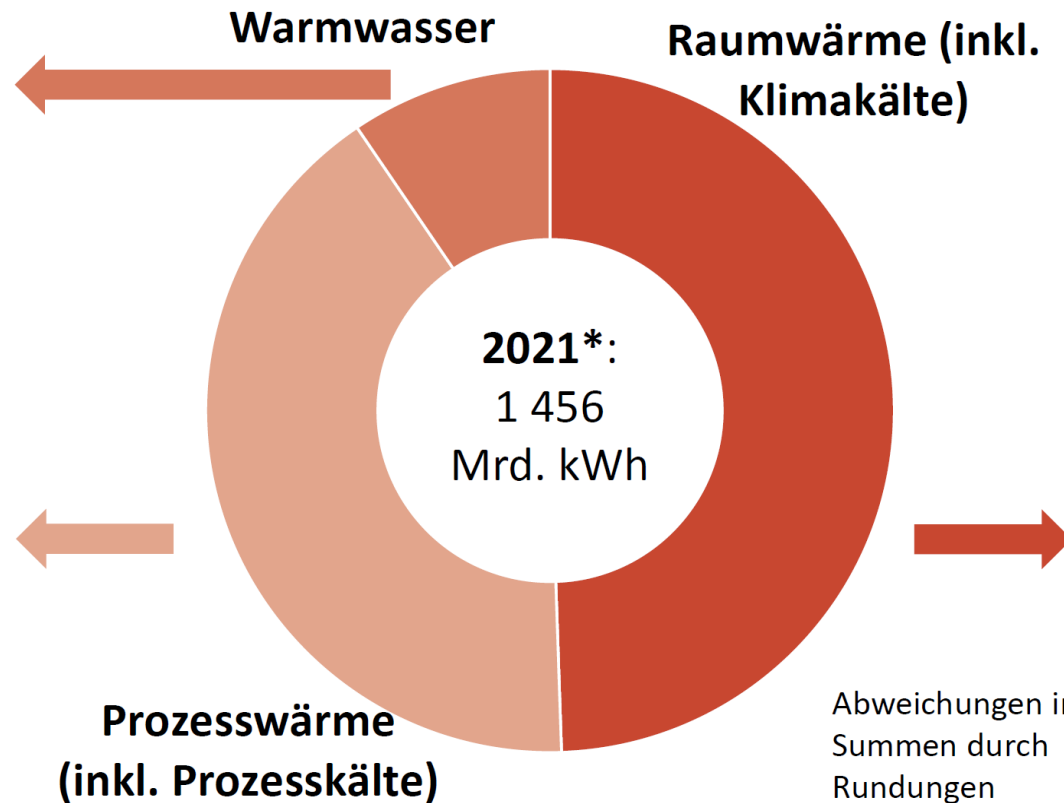
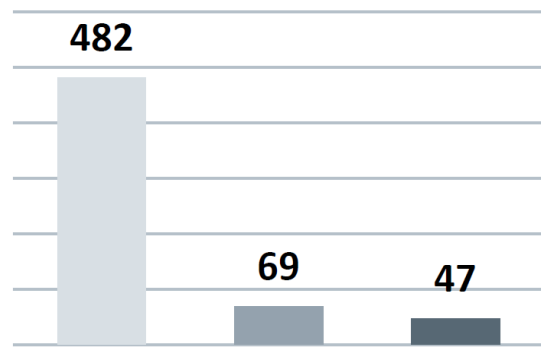

Anwendungsbereiche

- Raumwärme (inkl. Klimakälte) ■
- Prozesswärme (inkl. Prozesskälte) ■
- Warmwasser ■

Sektoren

- Industrie ■
- Haushalte ■
- Gewerbe, Handel, Dienstleistungen ■

Raumwärme 720 Mrd. kWh

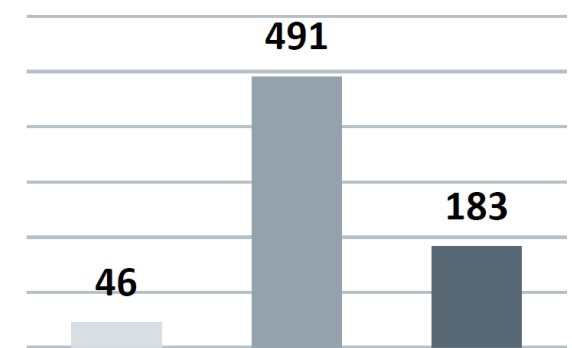

Energy sources for the heat supply of buildings in Germany



Despite the trend towards electric heat pumps, methane will in all likelihood remain a key energy source within the German heat supply for existing residential buildings within the next decades. Synthetic methane (SNG) may be an option for defossilizing the stock.

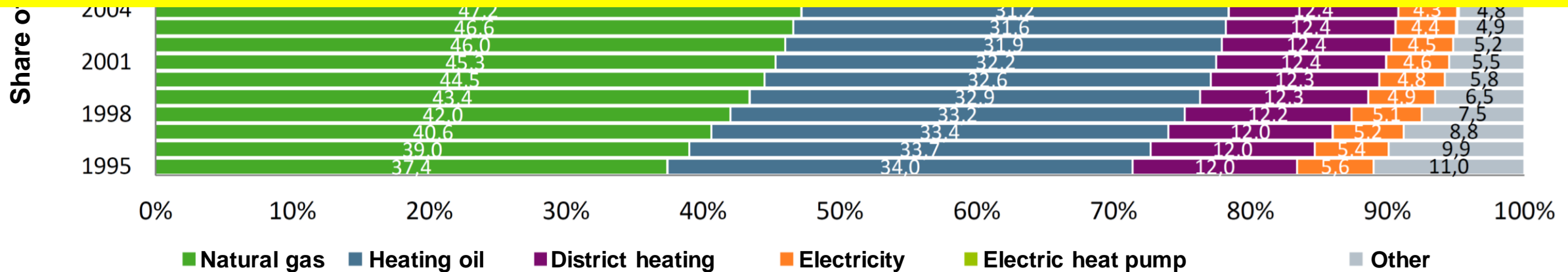

- ❖ Hydrogen-based molecules are an indispensable part of our overall global economy; we use them as a raw material as well as an energy carrier – and so far these molecules are fossil-based.
- ❖ Due to the need to transform our highly integrated global energy system towards more climate-compatibility, “green” molecules must be used. Taking technological, economic and systemic aspects into consideration the following developments can be observed.
 - The chemical industry demands today already substantial amounts of ammonia and methanol; these bulk chemicals will become more increasingly “green”.
 - Within the transport sector mainly the maritime and the aviation sector are demanding “green” molecules; for ship propulsion mainly ammonia and methanol and for long-haul flights FT-based PtL fuels are under discussion. Additionally, minor markets might emerge for special-purpose vehicles.
 - For heat provision within existing residential buildings synthetic natural gas (SNG) might be a promising option due to the extensively developed infrastructure. This is also true for selected applications in industry and commerce.
- ❖ Related to the already existing and most likely emerging markets “green” ammonia, “green” methanol, “green” methane and FT-crude are the most important hydrogen derivatives – and at least for a transition period these end-consumer markets are clearly bigger compared to the pure hydrogen markets.



Hamburg University of Technology (TUHH)
Institute of Environmental Technology and Energy Economics (IUE)
Eissendorfer Str. 40; D-21073 Hamburg