

A Review on Sensor-Integrating Machine Elements

Eckhard Kirchner, Thomas Wallmersperger,* Thomas Gwosch,* Johannes D. M. Menning,* Julian Peters, Richard Breimann, Benjamin Kraus, Peter Welzbacher, Jan Küchenhof, Dieter Krause, Erich Knoll, Michael Otto, Benjamin Muhammedi, Stephanie Seltmann, Alexander Hasse, Günter Schäfer, Armin Lohrengel, Stefan Thielen, Yvo Stiemcke, Oliver Koch, Arthur Ewert, Thomas Rosenlöcher, Berthold Schlecht, Artem Prokopchuk, Ernst-Friedrich Markus Henke, Felix Herbst, Sven Matthiesen, David Riehl, Ferdinand Keil, Klaus Hofmann, Florian Pape, Dennis Konopka, Gerhard Poll, Tobias Steppeler, Rico Ottermann, Folke Dencker, Marc C. Wurz, Steffen Puchtler, Thao Baszenski, Martin Winnertz, Georg Jacobs, Benjamin Lehmann, and Karsten Stahl*

This contribution summarizes the current state of research regarding so-called sensor-integrating machine elements as an enabler of digitalization in mechanical engineering and—if available—their application in industry. The focus is on the methodical aspects of the development of these machine elements in general as well as specific sensor-integrating machine elements that are either already in use or currently under development. Developmental aspects include the robust design of initially evaluated concepts for sensor-integrating machine elements as well as their modularization. Smart materials with sensory functions are included in the analysis as well as the differentiation with regard to add-on sensors. The aim of the authors interlinked by a special research program funded by the German Research Foundation (DFG) is to facilitate the exchange with other researchers with the help of the comprehensive overview given in this contribution. The contribution concludes with a brief discussion of open challenges, such as the energy supply and data transfer in rotating systems and also data security.

1. Introduction

In recent years, the desire for machine elements with sensory capabilities has increased dramatically. However, the methodical aspects are different for the various machine elements. Therefore, the aim of the present paper is to give a general overview of sensor-integrating machine elements, which are still in development or already in use.

The present, introductory section familiarizes the reader after a brief motivation in Section 1.1 with a basic understanding of the underlying idea of (standardized) machine elements and their differences from purpose-build design elements in Section 1.2. Next, the understanding of sensor-integrating machine

E. Kirchner, R. Breimann, B. Kraus, P. Welzbacher, S. Puchtler
 Institute for Product Development and Machine Elements
 Technical University of Darmstadt
 64287 Darmstadt, Germany
 E-mail: kirchner@pmd.tu-darmstadt.de

T. Wallmersperger, J. D. M. Menning
 Institute of Solid Mechanics
 TU Dresden
 01069 Dresden, Germany
 E-mail: Thomas.Wallmersperger@tu-dresden.de;
johannes.menning@tu-dresden.de

 The ORCID identification number(s) for the author(s) of this article can be found under <https://doi.org/10.1002/adsr.202300113>

© 2024 The Authors. Advanced Sensor Research published by Wiley-VCH GmbH. This is an open access article under the terms of the [Creative Commons Attribution](https://creativecommons.org/licenses/by/4.0/) License, which permits use, distribution and reproduction in any medium, provided the original work is properly cited.

DOI: 10.1002/adsr.202300113

T. Gwosch, J. Peters, S. Matthiesen
 IPEK – Institute of Product Engineering
 Karlsruhe Institute of Technology (KIT)
 76131 Karlsruhe, Germany
 E-mail: thomas.gwosch@kit.edu

T. Gwosch
 Product Development Group Zurich, Department of Mechanical and Process Engineering
 ETH Zurich
 Zurich 8092, Switzerland

J. Küchenhof, D. Krause
 Institute of Product Development and Mechanical Engineering Design
 Hamburg University of Technology
 21073 Hamburg, Germany

E. Knoll, M. Otto, K. Stahl
 Institute of Machine Elements, Gear Research Center (FZG)
 TUM School of Engineering and Design
 85748 Garching, Germany

elements used in the (German dominated) research community is outlined, see Section 1.3. During recent research activities, it has become obvious that a clear terminology is required to allow for instance designers and metrologists to talk about the same topics, see Section 1.4. Finally, it is rated helpful to provide a common understanding of the sub-functions of sensor-integrating machine elements (SiME) in the electronic or sensory domain which need to be provided in order to allow the sensor-integrating machine element to capture, process, and distribute measured signals, see Section 1.5.

1.1. Sensor-Integrating Machine Elements Pave the Way for Widespread Digitization

It has become obvious during the last few years, that the availability of high quality information on production processes and the respective machinery is the Achilles' heel of the digitization of engineering. One major reason for the lack of measured data out of production processes is the limited availability of compact and autonomous sensors at a reasonable cost. Whereas the automotive sector can evolve by the respective economy of scale purpose-build solutions for their products, many small and medium size

B. Muhammedi, S. Seltmann, A. Hasse
Institute of Design Engineering and Drive Technology (IKAT)
Chemnitz University of Technology
09107 Chemnitz, Germany

G. Schäfer, A. Lohrengel
Institute of Mechanical Engineering
Clausthal University of Technology
38678 Clausthal-Zellerfeld, Germany

S. Thielen, Y. Stiemcke, O. Koch
Chair of Machine Elements, Gears & Tribology
RPTU Kaiserslautern
67663 Kaiserslautern, Germany

A. Ewert, T. Rosenlöcher, B. Schlecht
Institute of Machine Elements and Machine Design
TU Dresden
01069 Dresden, Germany

A. Prokopchuk, E.-F. M. Henke
Institute of Semiconductors and Microsystems
TU Dresden
01069 Dresden, Germany

D. Riehl, F. Keil, K. Hofmann
Integrated Electronic Systems Lab
Technical University of Darmstadt
64283 Darmstadt, Germany

F. Herbst
Measurement and Sensor Technology Group
Technical University Darmstadt
64289 Darmstadt, Germany

F. Pape, D. Konopka, G. Poll
Institute of Machine Design and Tribology (IMKT)
Leibniz University Hannover
30823 Garbsen, Germany

T. Steppeler, R. Ottermann, F. Dencker, M. C. Wurz
Institute of Micro Production Technology (IMPT)
Leibniz University Hannover
30823 Garbsen, Germany

T. Baszenski, M. Winnertz, G. Jacobs, B. Lehmann
Institute for Machine Elements and Systems Engineering
RWTH Aachen University
52062 Aachen, Germany

companies with world-wide leading products suffer due to the described lack of compact and inexpensive autonomous sensors that are easy to integrate on the system level. Addressing this open need, a special research program (DFG Priority Programme 2305^[1]) was initiated by the German Research Foundation with the clear vision to develop compact and autonomous sensor solutions using machine elements as hosts to facilitate the implementation of sensors close to or even in the mechanical process, which provides benefits for the measurement quality. The machine element carries a sensor. Due to the integrated sensory functions, the machine elements are called Sensor-integrating Machine Elements. The authors of this paper are interlinked with each other within this special research program, their goal is to provide a comprehensive overview of the current state of research in this particular area. The headline of this introductory section matches the title of the research program.

However, due to the integration of sensor modules into the mechanical load-carrying structure of the machine element additional stress concentrations arise which lead in general to a reduced load-carrying capacity and stiffness of the machine elements. Hence, methods need to be provided for both researchers and practitioners to take this change in mechanical properties into account, which is a current research topic of the authors in the Priority Program mentioned above. Until now, there are, however, no dimensioning rules available on how to include the negative effects of the sensor integration into the equations for stiffness, strength, and other properties. Future research will address these topics and work on the open challenges described in Section 5.

1.2. Understanding of Machine Elements and Their Differentiation from Design Elements

The differentiation of machine elements from the more general group of design elements is motivated by the degree of standardization.^[2] *Machine elements* such as for example, screws, fasteners, and rolling element bearings are provided by many suppliers, with their interfaces being standardized, allowing for exchangeability, which is a mandatory requirement, especially for purpose-built, highly individualized machines. Cylindrical involute gears can be produced in a vast variety using standardized cutters. The same holds for shafts and axles and many different kinds of joints. All these are machine elements with standardized interfaces or production tools that allow for highly and internationally standardized dimensioning and optimization calculus. This understanding is common in research and education, especially in Germany, see for example, Kloos, Lechner, Schlecht, Schaeffler Technologies AG & Co. KG, Linke, Niemann et al., Sauer.^[3–11] However, the understanding might be slightly different on a global scale. The reader may consult the following text books by Rao, Ugural,^[12,13] and Childs.^[14]

On the other hand, *design elements* often come along with application specific design interfaces, they do not follow the before mentioned standards in calculus, production tools or interfaces.^[15] Design elements are understood to provide a certain function when applied into a machine context.^[16] A standardized deep groove ball bearing, being a machine element with no particular function, transfers into a design element

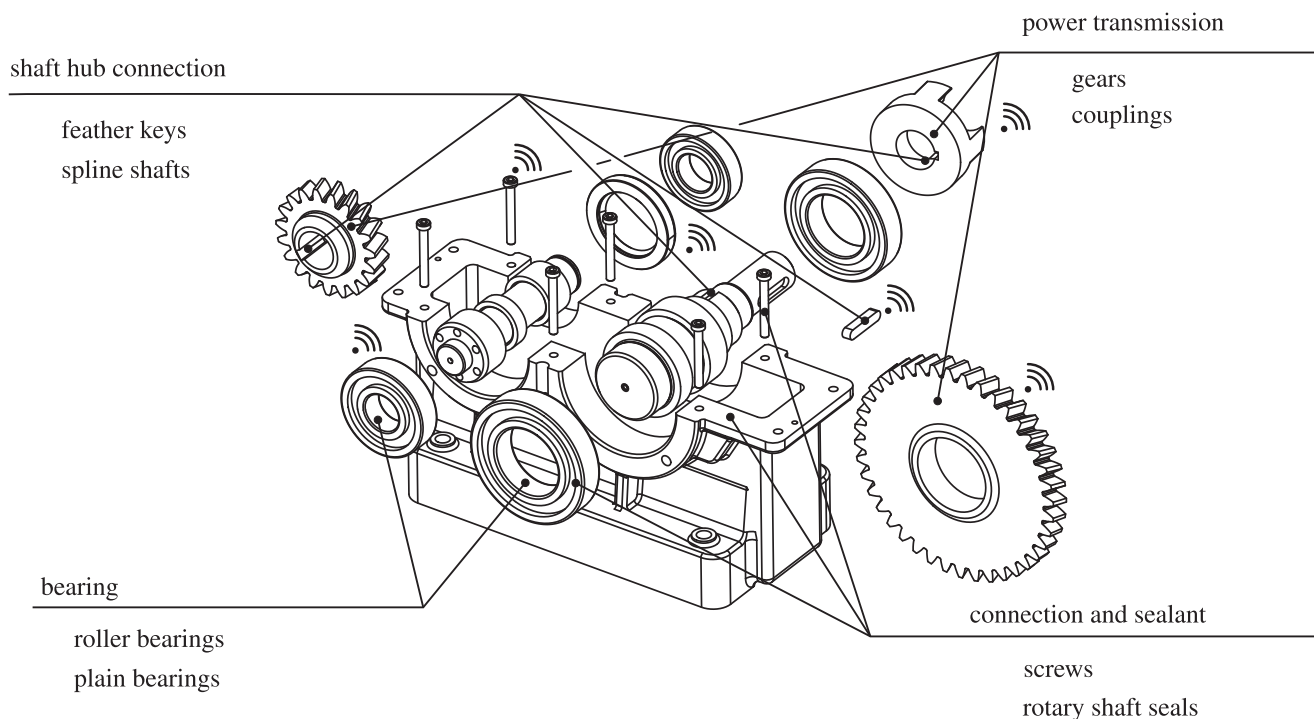

Figure 1. Generic gearbox with the main components shaft-hub connection, power transmission, bearing and connection and sealing, and their specific sensor-integrating machine elements that are the focus of research in the DFG SPP 2305 sub projects.

when integrated for instance as a fixed bearing of a fix-loose-bearing arrangement carrying a shaft; the fixed bearing enables the rotation of the shaft and transmits radial and axial forces during operation.

The importance of continuous research in the area of machine elements as an enabler for new technologies at the system level through innovation on the component level was recently described by Kirchner et al.^[16]

1.3. Classification of Sensor-Integrating Machine Elements

The classification of sensor-integrating machine elements is based on the sensor output^[17] or the functional structure of the sensor and way of integration in machine elements. The functional structure uses the elements *channel*, *transform*, *connect*, and *change*.^[18] Based on Vorwerk–Handing et al.,^[18] sensor-integrating machine elements must have a direct relationship between the channeled, transformed mechanical energy and the relevant sensor signals. Sensor-integrating machine elements are characterized by the fact that the function of the machine element is directly related to the measured variable, for example, the measurement of forces on a bearing or the temperature of the used lubricant. Often, measuring or predicting operating loads or damage to the machine element based on the flow of force through the machine element is also of interest.

The sensor output categorizes sensor-integrating machine elements by the physical parameters being measured or derived from the measurement, like pressure, force, temperature, or wear condition. From the perspective of the sensor function, the sensor system covers the partial functions that will be intro-

duced in Section 1.5. The main function is the supply of condition data of the machine element, for example, in order to evaluate the health condition of the machine or measure process parameters. Preliminary work in this field focused primarily on the measuring path and its associated disturbances.^[19,20] Therefore, sensor-integrating machine elements can be categorized on the one hand on the function of the sensor, but also on the other hand on the elements used for the sensor functions.

Alternatively, there exist sensing machine elements where the measurand has no relation to the quantity to be measured, such as for instance, a screw carrying a thermocouple; hence, these concepts are called *sensor-carrying* machine elements.^[18] Sensor-carrying machine elements require, in most cases additional designed space, such as for the VarioSense concept.^[21]

Finally, some machine elements comprise physical effects that can themselves be used as sensors as for instance the lubricating film in hydrodynamically operated rolling element bearings; hence, we talk about *sensory utilizable* machine elements.^[22–24] The extension from machine elements to the more general case of design elements is discussed in Harder et al.^[2] and Kraus et al.^[25]

Figure 1 shows a schematic representation of a gearbox using sensor-integrating machine elements, which are discussed in the present work.

1.4. Terminology: From Sensor Principles to Measuring Procedures

The research topic of sensor-integrating machine elements and their development is an interdisciplinary challenge by definition

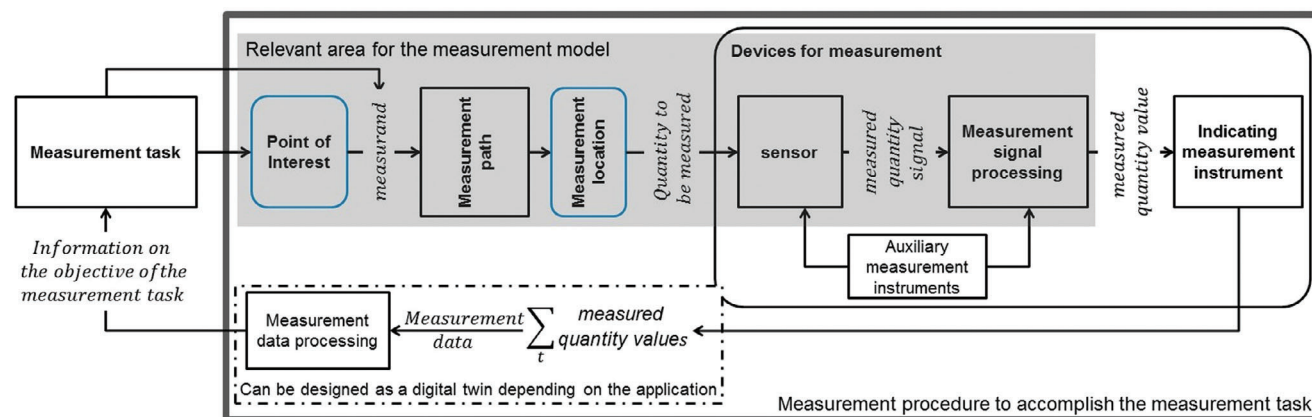

Figure 2. Structure of a measurement procedure based on Hausmann et al., Löpelt et al., Brinkmann, DIN 1319-1, Czichos & Daum, Czichos, and Anderl.^[26–32]

touching basic machine elements, mechatronic product development, as well as metrology. Hence, the terminology may be initially ambiguous and controversial; a definition of the most important idioms is required. The point of departure is the international dictionary on metrology.^[26] Relevant idioms and their relations for the following review are depicted in **Figure 2** and explained in this section.

The *measuring task* is the superordinate goal of a measurement using sensor-integrating machine elements. As an example, one may consider to capture the stress level of a component along its individual product life cycle. The measuring task is usually translated into capturing a specific quantity, the *measurand*, at the so-called *point of interest*. A distinction between the *measurement chain* for signal conversion inside the measuring device, which is explicitly defined in metrology, and the undefined *measurement path*, that is, the conversions outside the measuring device, is not made.^[26] From a metrological point of view, a measurement model is built starting from the measurand, which describes the effects of the changing measurand along the measurement path to the measurement location, that is usually converted into a measurable, electrical signal by the sensor.^[26] Depending on the length of the measurement path, further variables must be considered in the measurement model. To continue the example, one can measure the strain level at the component surface in a cross section considered critical and use a material law, for example, Hooke's law, to calculate the stress level as the quantity of interest.^[28]

In product development, the measurement chain reflected in the measurement model is divided into two areas: the area within a measuring device and the area within the system. The devices of measurement comprise the sensor and the measurement signal processing unit, an example of this are load cells. The area within the system describes the propagation of the signals, such as force flows or vibrations within the system components to the sensor. The transmission path between the point of interest and the input to the measurement system is referred to as the *measurement path* in the following. The measurement path is interesting from the point of view of product development as it can be heavily influenced by the positioning of the measurement equipment and by the design of the system components. The measurement path thus distinguishes between *in situ* and *ex situ* measurements.^[27]

If the measured variable and the input variable of the measuring equipment are identical or if the point of interest and the measuring location are very close to each other, the usual terminology is *in situ measurements*. Depending on the length and complexity of the measurement path, the complexity of the measurement model between the measured and the input variable increases, and more disturbance variables can have an influence, which increases the uncertainty,^[27] as will be discussed in Section 3.2.

In order to mitigate the effect of uncertainties, the state of the art of research uses the Guide to the Expression of Uncertainty in Measurement (GUM).^[33,34] The measuring device itself consists, as will be discussed in Section 1.5 of the measured variable acquisition, the measurement signal processing, the measured value output and any auxiliary devices.^[26,29,30] The measured variable acquisition proceeds according to the selected measurement principle, which usually leads to a domain transition from mechanical to electrical engineering and thus generates a measurement signal. The measurement signal is then transformed within the measurement signal processing unit by applying a measurement method to the actual measurement value.^[26,29] This is the output by a display or a data transfer unit from the measuring device. The measurement data generated by the individual measurement values can then be processed externally to obtain information on the actual measurement task. Depending on the measurement task, this can be done by post-processing steps and implemented for example, in a digital twin.^[32,35] The measurement procedure thus represents the sum of all the facilities and work steps that are necessary to fulfill the higher-level measurement task.^[26]

1.5. Sub-Functions of Sensor-Integrating Machine Elements—A Methodological Perspective

To enable a sensor-integrating machine element to gather information, it has to be able to perform several sub-functions on top of their standard mechanical functions, cf. **Figure 3**. First, a signal needs to be captured by the interaction of a sensor element or sensor principle with the base functionality of the machine element as per the definition of the class of sensor-integrating machine elements given in Section 1.3.

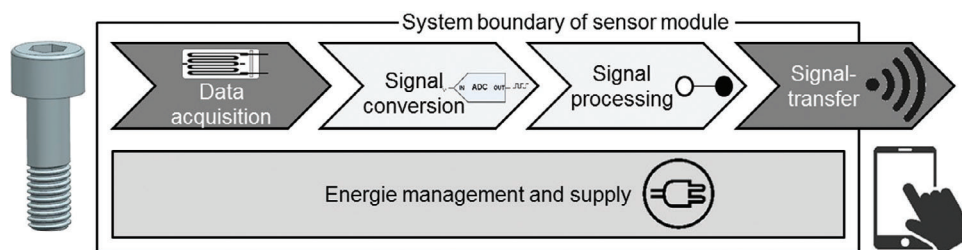

Figure 3. Sub-functions of sensor-integrating machine elements in the electronic-informational domain.

The signal is, in the most simple case, some resistance change that is proportional to for example, the mechanical tension applied. The signal is transformed, for example, by amplification or filtering, for better signal handling, cf. Figure 3. Afterward, the signal is processed, to separate for example, background noise from the signal of interest or to identify characteristic patterns such as governing orders in an acceleration spectrum. Finally, the signal is transmitted to a remote receiver outside of the machine element and its direct design vicinity. Concluding, the sensory functions have to be provided with electric energy to enable all the sub-functions. Hence, the sensor system hosted in the machine element needs to allow for these five sub-functions, given in Figure 3. Please note that the differentiation is not unambiguous and the sequence can vary depending on the specific design.

The differentiation of these sub-functions is motivated by the cognition of the fact that mechanical engineers most often consider only the capture of a signal and not its way from the sensor to some remote controller without a cable in between them. In order to be able to discuss about autonomous sensor nodes, it is important to consider all these particular functions. However, in the literature, this differentiation is in most cases neglected and the analysis of the signal processing chain is incomplete.^[18,27]

2. Sensor Materials and Sensor Principles

In the present section, first, a short overview of smart (sensor) materials and their multi-field interaction properties are given, see Section 2.1. Then, in Section 2.2, the sensory effects in machine elements are explained. Finally, in Section 2.3 the principles of sensor elements added to machine elements are briefly reviewed.

2.1. Sensory Materials

In order to realize machine elements or other structures with actuator or sensor functionalities, smart (or active) materials are often required.

These materials are able to reversibly change for example, their physical or chemical properties in reaction to an external stimulus and thus involve multi-field couplings, for example, electro-magneto-mechanical, thermo-chemo-electrical, etc.

In order to get an overview of existing smart materials, a categorization of some of the most important smart materials is given in the following:

- i) Thermostrictive materials;
- ii) Electrostrictive materials;
- iii) Magnetostrictive or magnetoelastic materials;
- iv) Piezoelectric materials;
- v) Electroactive polymers;
- vi) Electro- or magnetorheological fluids;
- vii) Photochromic materials;
- viii) Thermochromic materials; and
- ix) Electrochromic and electrooptical materials.

One exemplary representative of electroactive polymers are dielectric elastomers (DEs). DEs possess mechanical characteristics similar to biological muscles.^[36] Their mechanism is electromechanical, offering the opportunity for rapid and fully integrated control of actuation, sensing, signal processing, and energy harvesting. In their simplest embodiment, DEs are flexible capacitors consisting of thin, soft, dielectric membranes, such as acrylic tape or silicone rubber. A membrane typically having a thickness of 20 to 100 μm is sandwiched between two stretchable electrodes. This simple setup already represents a multi-functional device. Due to their multi-functionality, DEs are very promising candidates to design novel, fully integrated, autonomous sensor-actuator systems^[37] for machine elements, see for example, Section 4.4, with embedded signal-processing capability and internal energy harvesting to transform mechanical into electrical energy and vice versa, see for example, Han et al., Priya and Inman, Vullers et al., Beeby et al.^[38–41] There is an enormous potential of fully integrated and miniaturized, multi-functional DE sensor-actuator systems. This makes them perfect candidates for the development of intelligent machine elements of the future.

More details on smart materials and their specific characteristics can be found, for example, in Grohmann et al., Chopra & Sirohi, Leo, Sobczyk et al.^[42–45] In the following, the focus is on smart materials applied to sensor-integrating machine elements. Their specific properties are summarized in Table 1. An active strain versus stiffness plot for selected smart materials is given in Figure 4.

2.2. Sensory Effects

Sensory effects in machine elements typically use the basic physical principles of electrical resistance, capacity, or inductivity in combination with properties directly linked to the primary mechanical function of the machine element. When sensory effects offer a promising signal-to-noise ratio, they can be used as a point

Table 1. Overview over smart sensor materials.

Smart material	Specific representative	Multi-field interaction	Stimulus properties	Reaction properties	Stiffness	Active frequency
Piezoelectric ceramics	Lead zirconate titanate (PZT), barium titanate, lead titanate, etc.	Electro-mechanical	Strain gauges (\Rightarrow shaft-hub, screws), acceleration (\Rightarrow gears, plain bearings), mechanical force (\Rightarrow shaft-hub, screws)	Surface charge, electric field	60–93 GPa	Up to 1 MHz
Piezoelectric polymers	Poly(vinylidene difluoride) (PVDF), etc.	(Thermo-) electro-mechanical	Mechanical stress	Excellent sensor, surface charge	2 GPa (PVDF)	Up to 100 kHz
Electrostrictive materials	Lead magnesium niobate (PMN) lead magnesium niobate-lead titanate (PMN-PT) lead lanthanum zirconate titanate (PLZT)	Electro-mechanical	Pressure, acceleration, stress, strain	Surface charge, electric field	20 – 97 GPa	Up to 10 kHz
Magnetostrictives	Terfenol D	Magneto-mechanical	Force, torque	Magnetic field	25–35 GPa	Up to 1 MHz
Shape memory alloys	Copper-aluminum-nickel and nickel-titanium (NiTi) alloys, etc.	Thermo-mechanical	Strain gauges, temperature (\Rightarrow couplings)	Thermal field	25–80 GPa	1 Hz up to 10 Hz
Ionic electroactive polymers	Polyelectrolyte gels (PNIPAAm, etc.), Polymer-metal composites	Chemo-electro-mechanical	Mechanical strains, stresses, temperature	Electric field	Up to 100 kPa 15–130 MPa	0.01 mHz–1 Hz Up to 30 Hz
Electric electroactive polymers	Dielectric elastomers (silicone)	Electro-mechanical	Mechanical strains, stresses (\Rightarrow couplings)	Surface charge, electric field, capacity	10–100 MPa	Up to 1 kHz

of departure to develop a concept for a sensory utilizable machine element, cf. Section 1.3.

Resistive effects use the dependency of the electrical resistance on the deformation of the material. The effect is small for instance in tensile steel members of high performance tooth belts,^[46] and offers sensory potential when combined with additively manufactured plastics.^[47] On a large scale, the resistive effect is the basis for strain gauges as well as for thermocouples which are used as add-on sensors, see Section 2.3.

Capacitive effects are the basis of the sensory concept for rolling element bearings, in which the isolating lubrication film thickness depends on temperature, relative speed, and bearing load and can be used to calculate the current load and speed as described by Martin et al.,^[22] Schirra et al.^[23,24] and Kirchner et al.^[48] Similarly, the capacitive effect can also be detected in hydrodynamic journal bearings,^[2,49] and even in dry lubricated sliding

bearings.^[50] The idea to use the electric property of the (hydrodynamic) lubrication film as such was used even earlier to estimate the lubrication film thickness as an application in machine elements.

The inductive effect is used in coil springs, as described in Harder et al.^[2] Several authors have proposed different models to correlate the change in inductivity with force or displacement applied to the coil spring. The most recent reference for the sensory usage of the inductive effect is given in Van der Weijde.^[51]

2.3. Add-On Sensors

The concept of add-on sensors typically requires additional building space for the sensor one good example is the VarioSense concept,^[21] which is shown in Figure 5. Differing from the class of sensor-carrying machine elements, the sensor unit comes along as an extra component.

As already stated, the additional building space or the additional inertia of for example, a torque measuring flange needs to be considered in the system design. In a developmental setup, add-on sensors can be easily applied, whereas the additional packaging claim is disadvantageous, for instance, in automotive engineering. The added sensor is then most often highly integrated into the structure, which makes re-use difficult.

In addition, the wiring harness of the add-on sensor imposes restrictions on the possible modes of operation, for the example of the VarioSense concept, the outer race must be stationary to protect the cable from damage, cf. Figure 5.

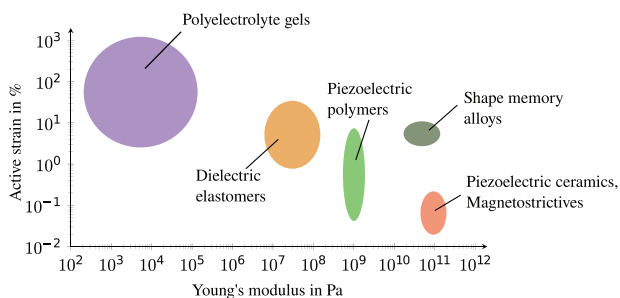

Figure 4. Schematic plot of active strain versus Young's modulus for selected smart materials.



Figure 5. VarioSense concept: Add-on sensors for temperature, inner race speed, and bearing load applicable to tapered roller, cylindrical, and deep-groove ball bearings^[52]; with kind permission of Schaeffler AG.

Alternative solutions for add-on sensors include (standardized) load cells or torque measuring flanges, which are widely offered as ready-to-build-in products. However, each solution comes along as a subsystem of its own, requiring additional building space and impacting the systems' performance through increased compliance as for the load cell or additional inertia for the measuring flange.

3. Engineering of Sensor-Integrating Machine Elements

Sensor-integrating machine elements (SiME) are high-integrity mechatronic systems that have been designed for use in a wide range of advanced and complex systems. Therefore, there are high requirements for the development of such sensor-integrating machine elements. To meet these challenges, methodical approaches and concepts have to be developed. It includes both (i) conceptualizing and (re-)designing the mechanical machine elements and (ii) designing and integrating the sensor systems, including data processing. Based on these challenges, this section discusses methodological approaches for engineering sensor-integrating machine elements.

3.1. Methodically Guided Conception for Sensor-Integrating Machine Elements Supporting Innovative Measurement Methods

There are many challenges in developing SiME as a mechatronic product. First, various disciplines such as mechanics, electronics, sensors, and information technology are involved and share the same design parameters, which can lead to conflicts^[53] and require trade-offs. Second, strict requirements apply to ensure the usability of the machine elements. Most important is that the mechanical interfaces must be preserved to allow retrofitting of existing machines or plants. Also, standards and guidelines that exist for the machine elements should not be harmed by integrating the sensors.

This struggle to integrate sensing functions without reducing the mechanical functions can be observed in the state-of-the-art. Some approaches consider mechanical weakening or modification of mechanical interfaces (external dimensions) to achieve the sensing functionality, see Section 4. Existing solutions are

not able to provide sufficient sensing functionality while replacing conventional machine elements in terms of space neutrality, mechanical interfaces, and installation conditions.

To develop solutions that balance mechanical and sensing functions, methodical support is necessary. This support needs to address the interdisciplinary challenges by focusing on enabling the engineers of the involved disciplines to negotiate for their functionalities. Therefore, models that connect the function to the structure and modifiable parameters need to be created (function-behavior-structure models^[54–56]). With that, balanced solutions tailored to the individual use-cases of the machine elements can be obtained.

Since many machine elements have to comply to standards and guidelines, testing is an important aspect. Not only at the end, but during the whole development process, testing is intertwined with the design^[57] and should explicitly be emphasized in a methodology for developing SiME.

Furthermore, reliability of SiME as a complex mechatronic system in small spaces is especially challenging. Further research is necessary to see if the existing testing methods cover reliability assessment of SiME.^[58]

An overview of the methods and activities already used in the state of the art of SiME development can be found in Peters et al.^[59] and is summarized below: There are many state-of-the-art methods to support product development. There is the VDI 2221 for developing technical products and systems^[60] with extensions and adaptations such as the procedure model published in Matthiesen,^[56] for example, or the VDI 2206 for developing mechatronic systems.^[61] Stage-gate processes are also widely used in industry. Even though they provide generic support on a macro level, they cannot fully support developing SiME due to the specific interdisciplinary challenges.^[62]

In order to propose appropriate support for the development of SiME, the challenges need to be specified. Peters et al.^[59] clustered the challenges and found that one of the main challenges is the shared design parameters of the disciplines involved, for example, the design space volume for the sensing function. From a mechanical perspective, this design space should be as small as possible to reduce the weakening of the machine element and not change the external dimensions to preserve the primary function of the machine element. From an electronics/sensor perspective, the design space should be large enough to accommodate the sensors and electronics needed to meet the secondary function requirements for measurement quality

(resolution, signal-to-noise ratio, and data rate). Also, it should be located where physical quantities of interest can be measured, which mostly coincides with locations of high stresses, that is, weak points of the machine elements. Maximizing measurement quality usually results in a larger design space volume required for sensors and electronics, which compromises the strength of the structure. As a solution for developing SiME, a challenge-specific test-driven development framework that triggers negotiations between disciplines and trade-offs is needed. To support efficient negotiations, models that link the functions of both the mechanical and sensory parts to the modifiable parameters have to be developed for the machine elements.

3.2. Achieving Robustness in Measurement Procedures Based on Sensing Machine Elements

A technical system is generally defined as robust when it has limited or reduced functional variation, even in the presence of disturbance factors.^[63] For the realization of robustness in technical systems, approaches and strategies can be found in literature, which are mainly oriented toward the cause-effect relationship between disturbance factors and system behavior.^[64]

The development of robust measurement procedures, in particular of the devices of measurement used therein, such as SiME and the associated measurement signal processing, represents a subject of current research.^[65] Based on the definition of robustness given above, disturbance factors can be differentiated into three categories according to Taguchi et al.^[63] Disturbances due to external causes (e.g., temperature, vibration), disturbances due to internal causes (e.g., wear, deterioration), and disturbances due to manufacturing or assembly tolerances. In the context of the development of robust measurement procedures, the first two categories are particularly relevant, as they have a time-dependent behavior and occur and vary depending on the context of the use of the system in which the sensory function is to be integrated.^[65] Furthermore, their temporal behavior is usually not exactly predictable.^[66]

In order to be able to develop robust measurement procedures, it is first necessary to generate knowledge within the framework of an analysis with regard to occurring disturbance factors and their impact on the measurement procedure and the components used in it.^[67] Based on the disturbance factor control list by Welzbacher et al.,^[68] the disturbance factors occurring in the context of use of the measurement procedure can be systematically identified. The disturbance factors listed in the control list are linked to the respective domain-specific flow and effort variables, the product of which describes the energy flow induced by disturbance factors in or out of the system. Based on these two characteristic variables, the impact of occurring disturbance factors on the measurement procedure and the corresponding model of evaluation used in the measurement signal processing can subsequently be determined.^[68] For this purpose, for example, the effect graph developed by Kraus et al.^[25] can be used to systematically identify dependencies between occurring disturbance factors and the function variables and design parameters contained in the model of evaluation in an automated manner. These dependencies are called data or model uncertainty, depending on the influenced quantity.^[68] Based on the identified dependencies,

an evaluation of the criticality of occurring disturbance factors is subsequently carried out, on the basis of which an objective decision can be made regarding the necessity of measures for consideration.^[69] To manage critical disturbance factors or the caused data and model uncertainty, measures can be developed on the basis of the robust design strategies by Mathias et al.^[70] Potential measures include, among others, the extension of the measurement procedure for the measurement detection of occurring disturbance factors in order to compensate their impact in the course of the measurement data processing, as well as the constructive adaptation of the measurement path.

3.3. Modularization of Microelectronic Sensor Systems

In modular product development, products can be generated from modules. Modular products but also the modules themselves can be described as a special form of composition, as they are the result of combining individual components in a favorable way. The number of variants of the product results from the number of variants of all individual modules. By reducing the number of variants of the individual modules, economies of scale can be achieved.^[71] Modularity can be understood as a gradual entity of a spectrum of products or systems rather than a single product and can be characterized by five basic characteristics. According to Salvador,^[72] these are i) commonality (use of components or modules in several products), ii) combinability (use of modules to configure product variants), iii) functional binding (1:1 or $n:1$ mapping between functions and modules), iv) interface standardization (physical standardization of the interfaces of modules), and v) decoupling (interaction and binding between modules are weaker than the internal coupling of module components). These characteristics are themselves gradual parameters and in their totality determine the overall degree of modularity. The development of modular product families offers the potential to provide a large external variety of products, with a low internal component variety and process complexity by using a limited set of defined modules.^[73] As Breimann et al.^[74] have shown, the combination of different simple machine elements with different measurement tasks and associated measurement quantities results in a large set of possible sensor system configurations of SiME. These different configurations differ in their power requirements, data transmission rate, and sampling rate. This necessitates the use of application-specific components and their configuration toward a functioning sensor system to achieve the required characteristics. The resulting need for variant management can be addressed with strategies of modular product development. In order to develop and implement a modular kit for SiME, suitable methods are needed. In the following, general methods of modularization are discussed, which are independent of the type of system to be modularized. Subsequently, more specific methods for mechatronic systems are presented and the modularization of sensor systems is discussed within this scope. Finally, an example from the industry is shown in which the modularization of sensor systems for SiME has already been successfully realized.

Modularization methods can be divided into technical-functional and product-strategic approaches, depending on the focus.^[73] In technical-functional approaches, modules are usually retrieved by analyzing the component coupling

	Component A	Component B	Component C	Component D	Component E
Component A	1 2 0 0		2 0 1 1		
Component B					
Component C	0 0 2 1				
Component D			2 X 2 X	0 2 0 2	
Component E					

Types of relations

S	E	Energy
I	M	Material

Spatial Information

Partial functions	Component A	Component B	Component C	Component D	Component E	Component F	Component G	Component H	Component I
Module drivers									
Carry-Over									
Technology Push		●							
Planned Design Change					●	◐	○		
Technical Specification									
Styling		◐		●					○
Common Unit									
Process/Organisation		○			●	●	◐		
Separate Testing									
Black-Box-Engineering									
Service/Maintenance		◐			○	○	○		
Upgrading									
Recycling		◐		●					◐
Sum of all module drivers									

Figure 6. Left: Example of a design structure matrix based on Krause & Gebhardt.^[73] Right: Example of a module indication matrix based on Krause & Gebhardt^[73] and Erixon et al.^[78]

and the functional conditions. Relevant methods in this field are design structure matrix (DSM),^[75] structural complexity management^[76] using multiple-domain matrices (MDM) and building functional modules.^[71] In the DSM, shown in **Figure 6** on the left, the components are given in the form of a DSM, that is, the linkages between the components are depicted, taking into account different dependencies. Examples of different linkages are spatial, energy, information, and material relations. Subsequently, the matrix can be structured, so that clusters of components form, whose grouping in assemblies or modules produces synergies for the product as a whole.^[77]

Product-strategic methods aim to support the medium and long-term strategies of the company and the individual product life phases by means of targeted module definition. Due to the different potentials of modular product structures for all product life phases, integrative methods exist that are dedicated to the combination and harmonization of the requirements for modularization from different perspectives.^[73] In his modular function deployment, Erixon et al.^[78] focuses on the product strategy perspective and categorizes the advantages of all phases into module drivers that can be used to optimally design a product architecture from the perspective of each life cycle phase. The modular function deployment is based on the idea of optimizing the modular product structure according to module drivers. These module drivers represent requirements from different stakeholders in development, which are assigned to the different life phases of the respective product. Likewise the components are clustered in such a way that these product life phases benefit from favorable characteristics. For this purpose, the components are plotted into a module indication matrix and compared with the module drivers, as shown in **Figure 6**. Here, the relation of the module drivers and components is registered and plotted into the matrix. This makes the structuring of the components into modules—in dependence of these relationships—possible. The relations are indicated via symbols. However, for further analysis, the relations can be quantified.

The *integrated product development and mechanical engineering design (PKT) approach for the development of modular product families* is an integrative methodology that provides harmonization of the different product strategy potentials as well as a technical-

functional perspective in modularization.^[73] While modular product architectures offer a strategy to cope with increasing complexity, there has been limited focus on modularization practices and the impact of modularization on the mechatronic domains of mechanics, electronics, and software.^[79] Mechatronic systems represent an interaction between the domains of mechanics, electronics and computer science, so that methods for developing mechatronic systems need to consider all three domains and must ensure the compatibility of the domains.^[61] For the design of a mechatronic system architecture and the holistic system modeling and synthesis, systems engineering is considered a suitable integrative method.^[80] This integration can be achieved by means of a data management system and can be realized by a model-based approach.^[81] The data elements of the requirements, functions and physical structure can be modeled separately and independently of the discipline and then transferred into an overall model.^[82] To enable a systematic design process of mechatronic systems with a high integration density, a multidisciplinary integrated design is required.^[83] In order to organize the design activities of the various disciplines and to organize and achieve multidisciplinary integrated design, Zheng et al.^[83] propose a design methodology based on a multidisciplinary interface model to ensure consistency and traceability between micro and macro levels. In line with systems engineering, an extended *V-model* is used as the macro-level process, and a hierarchical design model is used as the micro-level process in the proposed design methodology. Therefore, in the following, methods of modularization are shown that address this interdisciplinarity. Van Beek et al.^[84] present a modularization scheme for mechatronic systems with function modeling. Their approach uses function-behavior-state (FBS) models to derive the entity of relationships, automatically building the DSM based on their FBS model.^[84] Schuh et al.^[85] extend functional modules by the introduction of mechatronic functions in order to build mechatronic function modules. While mechatronic modular systems can be developed using these approaches, the various development disciplines involved are not explored further. Askhøj et al.^[86] have developed five practices for the development of modular mechatronic products based on analyzing the experiences of different companies. These practices

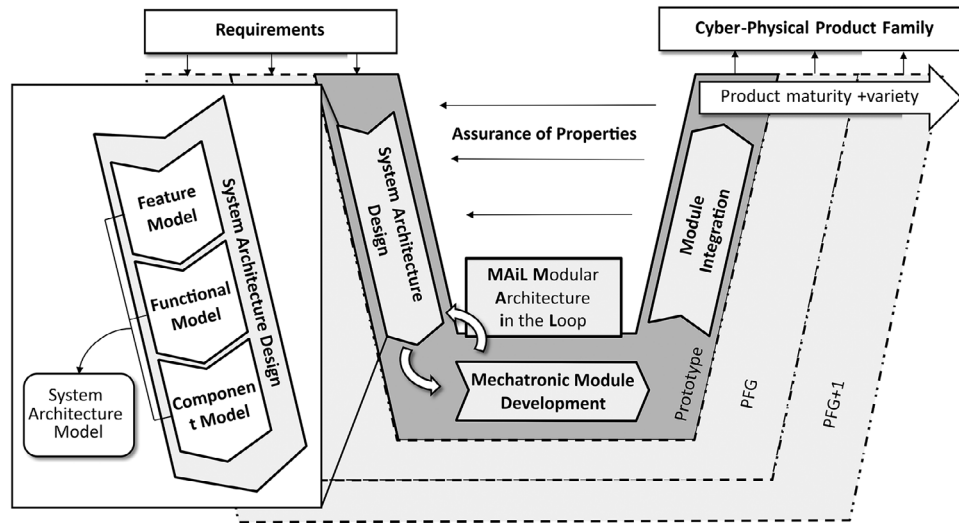

Figure 7. Adapted V-model for the development of cyber-physical product family generations (PFG). Reproduced under the terms of the CC BY-NC-ND 4.0 license. Copyright, 2022 The Authors.^[87]

are experience-based rules that simplify working with modular mechatronic kits. These practices were integrated into the so called MESA tool (Mechanics, Electronics and Architecture tool) by Askhøj et al.^[79] This tool allows to coordinate the development process of modular mechatronic systems. Silo-driven modularization tends to lead to the situation that one of the domains dominates the modularization process. The MESA tool enables the developers to map the changes in one domain to the resulting changes in other domains. Küchenhof et al.^[87] present a modified V-model, locating the product architecture on the left-hand side (Figure 7) incorporating cross-domain structures. Starting with the identification of the relevant requirements, the system architecture is created by mapping the product features, functions, and components in a system model. The mechatronic modules can then be developed in a suitable manner and are then integrated again on the right-hand side to form an overall system. This can be done iteratively for the development of successive product family generations (PFG).

In Küchenhof et al.,^[88] dependencies from trends via features down to the component level, are already represented and elaborated in a matrix-based manner including mapping of the respective DSM and MDM of the product architecture. The matrix-based mapping of the extended Design for Variety framework makes it possible to assess the impact of variance in a new product family generation in two dimensions with the

help of graph analysis software. One is the assessment of the impact of new product features on components (multi-domain change propagation) and the other is the assessment of the impact of changed components on other components (single-domain change propagation) as a secondary impact on the product structure.^[88] Also the interactions between the discipline-specific architectures must be considered. These are to be analyzed and made transparent accordingly which can be done using the MDMs shown in Küchenhof et al.^[88] Zuefle et al.^[89] separated the product architecture into the different discipline architectures which could be mechanical, fluidical, electrical, software, and others as shown in Figure 8. The correlation of the product DSM and the relevant development disciplines results in a new MDM called the Module Harmonization Chart (MHC).

As shown in Figure 9 on the right, compared to analyzing and mapping only the integrated product architecture, analyzing the unique architectures adds value to the integration of the overall system architecture. Discipline-specific architectures are created by selecting the appropriate components based on the MDM. Thus, responsibilities and relationships to development disciplines are mapped in addition to the couplings in the DSM and can then be used to build discipline-specific modules.

Figure 10 shows the various module sections designed as a possible harmonized result of the modularization in the MHC

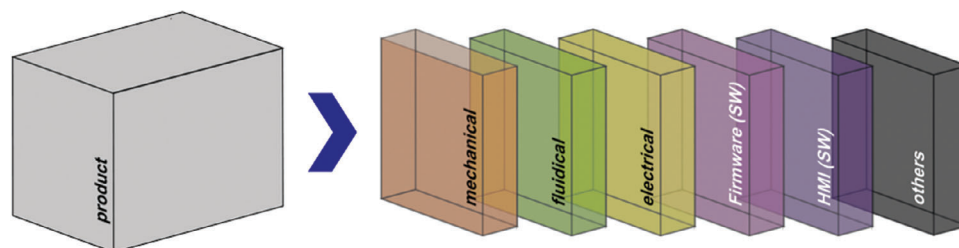

Figure 8. Separation of a product architecture into the individual discipline architectures, based on Zuefle et al.^[89]

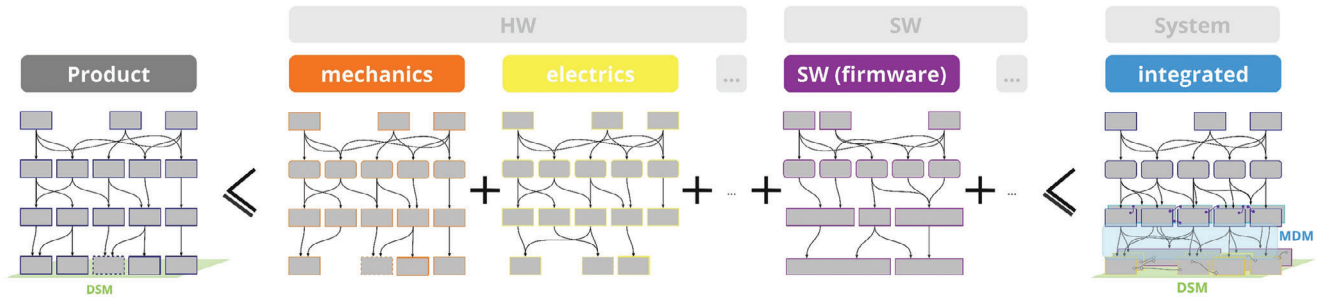

Figure 9. Derived architecture partitioning into different discipline architectures with DSM and MDM used to build mechatronics modules, based on Zuefle et al.^[89]

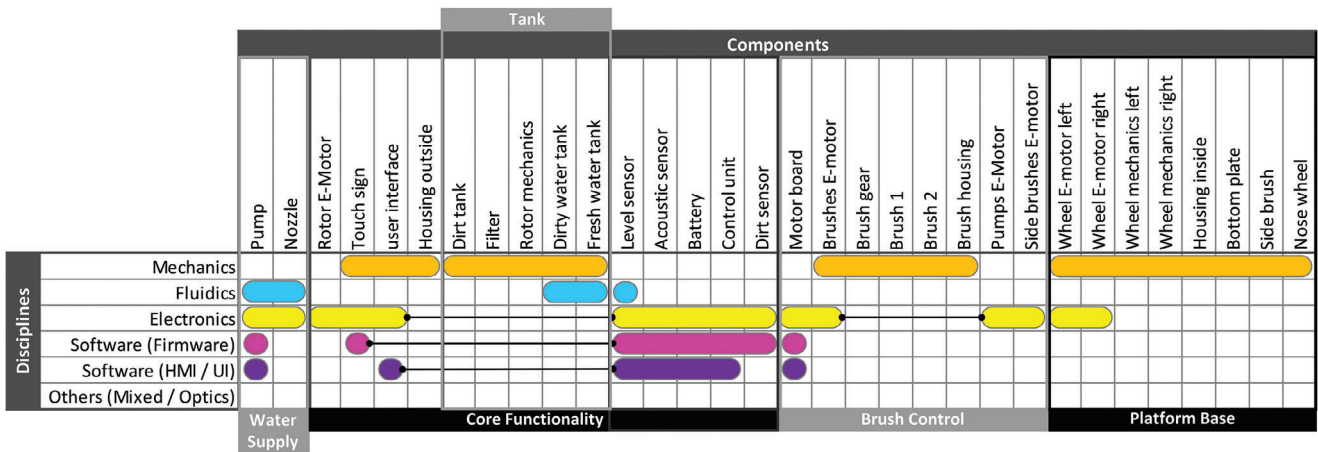

Figure 10. Harmonized mechatronic modules and team clusters corresponding to the various development disciplines, based on Zuefle et al.^[89]

based on the classification and assignment to develop disciplines for the example of a vacuum cleaner robot. The components are located in the columns and the disciplines are represented in each row. The modules are shown as a physical conglomerate of components with corresponding frames and as team clusters of the corresponding development disciplines with the respective colors.

Harmonized modularization can enable cross-disciplinary teams to be formed whose organizational structure fits the modularised product architecture. This arrangement discourages silo-driven thinking and allows developers from a variety of disciplines to work together on the same module.^[89]

The description of the modular architecture can be supported by system models. The Configuration Network Diagram (CND) according to Seiler & Krause^[90] shown in **Figure 11** maps product features (which are derived from the requirements) to the product components which themselves are associated with modules. The elements and relations depicted in Figure 11 can be modeled in the systems modeling language SysML.

Otto et al.^[91] developed guidelines for the modularization of mechatronic products. Here, field boundaries are used to define module boundaries on functional and structural product level. A total of eight guidelines are presented, divided into *Guidelines for Modularity and Embodiment in the presence of Fields* and *Concept*

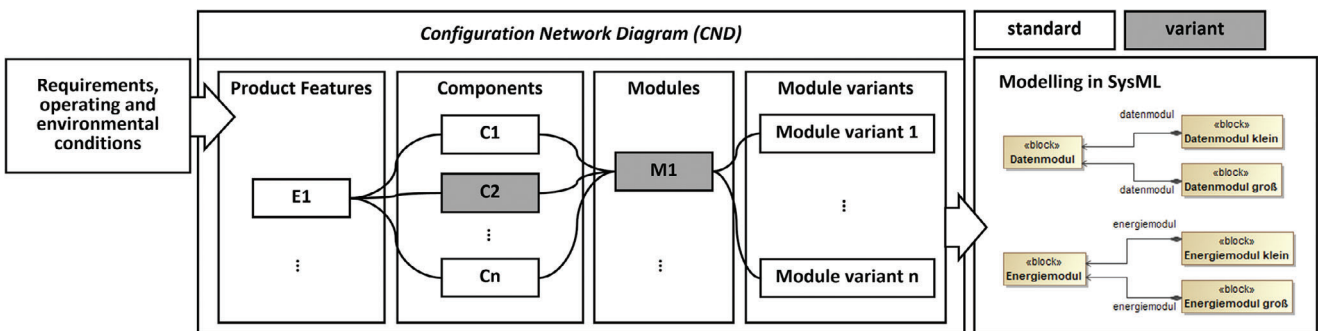

Figure 11. Generic Configuration Network Diagram (CND) according to Seiler & Krause^[90] for the development of a model-based configuration system.

	Component A	Component B	Component C	Component D
Disturbance Factor 1	S	I	E	S
Disturbance Factor 2	A	E	S	A
Disturbance Factor 3	I	A	I	E
Disturbance Factor 4	I	I	I	A

Figure 12. Components, disturbance factors and their relations plotted in a matrix based on Breimann et al.^[92]

Generation Guidelines.^[91] Breimann et al.^[92] took up this idea and presented a method by which module boundaries can be drawn based on the occurrence of disturbance factors and their effect on components. This method thereby represents a link between modularization and robust design. The approach also relies in representation in a matrix. Here, components are plotted against disturbance factors and their relation between the component and disturbance factor is recorded, see **Figure 12**. Each of the components either emits a disturbance factor (E), is affected by a disturbance factor (A), is measuring the disturbance factor (S), or the relation can be neglected (I).

There are no dedicated approaches for the modularization of sensor systems, especially in SiME. Wang et al.^[93] present a modular six-axis sensor based on low-cost sensors. However, the approach is not generalized or applied to other metrics and applications. Thus, no methods are derived from the development and no direct transfer to SiME can be done.

Outside the research context, the company Core Sensing has had success in the field of modular sensor-integrating machine elements. However, the modular system has so far been limited to the integration of sensor systems into shafts. Compared to other commercial SiME solutions, however, in addition to battery-powered systems and those that can be charged via induction, stand-alone systems that can be supplied with energy via energy harvesters are also offered. However, the solutions offered by Core Sensing are limited in terms of installation space, as a minimum diameter of 14 mm is required to integrate the systems.^[94]

In summary, the development of SiME requires a large amount of special solutions due to the multitude of possible application scenarios. For this, the modularization of sensor systems within the development of SiME offers a possibility to provide this demand for solutions efficiently. So far, however, there is a lack of methodological evidence to support this. The successes achieved so far in modularization are able to cover a range of measurands and application scenarios, but they are limited to a specific machine element. Through the methodically supported development of SiME and the implementation in a modular construction kit, common modules could be identified and synergy effects between the different projects and the machine elements could be used. Above all, its implementation with model-based approaches can make a sound contribution to the guided modularization of microelectronic sensor systems by systematizing

development data and making the resulting knowledge available for subsequent developments.

4. Sensor-Integrating Machine Elements

The present section targets comprehensive descriptions of the current state-of-research regarding different types of sensor-integrating machine elements. Since there is no natural hierarchy of machine elements except the “rule” of every researcher considering their own machine elements the most important one—the reader may consult the text books quoted in Section 1.2 for something like a natural way to subdivide machine elements. In the present work, the following sequence is chosen for no particular reason: gears (Section 4.1), shaft-hub-connections (Section 4.2), seal rings (Section 4.3), couplings (Section 4.4), screws (Section 4.5), rolling, and finally plain bearings (Section 4.6).

Sensor-integrating machine elements, according to Section 1.3, are conventional machine elements that are extended by sensor functions, cf. Section 1.5. An ideal sensor-integrating machine element is characterized by the following properties to overcome the shortcomings of the current state of industrial application described in Section 1.1:

- i) simplicity for system integration;
- ii) neutrality of design space with regard to standardization for geometric and functional interchangeability of conventional machine elements;
- iii) simplicity in data acquisition and analysis; and
- iv) integrated data pre-processing.

The following section focuses on the aspects of design space of sensor systems with elements from microsystems technology, materials and sensor principles, energy systems as well as signal and data transmission. Since this is still an area of current research, the sensor-integrating machine elements described in literature may not have all four of these properties. In particular, design space neutrality is often not given.

4.1. Gears

4.1.1. Motivation for Sensor-Integrating Gears

Gears are generally used in many applications like helicopters, aircraft, trucks, trains, cars, agricultural machinery, construction

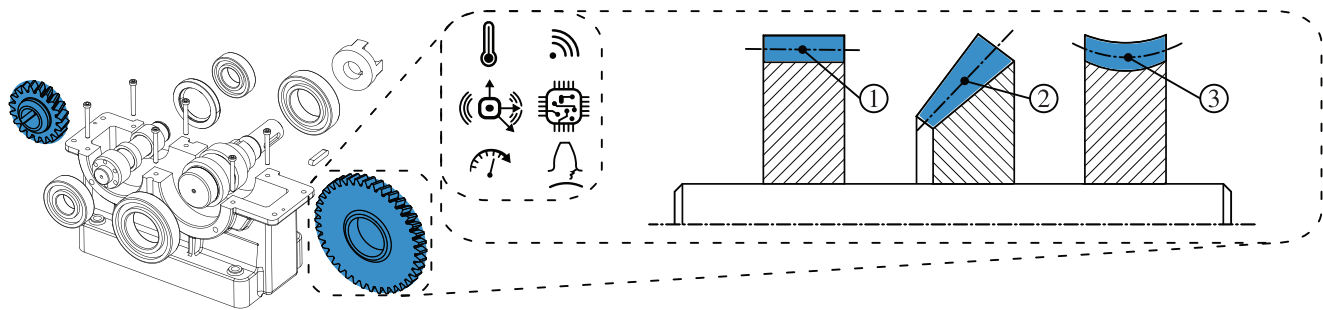

Figure 13. Sensor-integrating gear box, focusing on sensor-integrating gears and their measuring tasks, exemplified by a cylindrical gear (1), a bevel gear (2), and a worm gear (3).

machinery, ships, and many others. **Figure 13** shows the application of sensor-integrating gears in a gear box. To achieve high reliability, much research has been conducted in the past to investigate fatigue and failure mechanisms for example, by Touret et al.,^[95] Elforjani et al.,^[96] Lei et al.,^[97] Al-Arbi,^[98] Vietze et al.,^[99] Pellkofer et al.,^[100] Hein et al.,^[101] Sagraloff et al.,^[102] Roth et al.,^[103] Fromberger et al.,^[104] and Sendlbeck et al.^[105] Gear monitoring is used in critical applications like helicopter gearboxes, for example, with the health and usage monitoring systems (HUMS), for example, by Dempsey et al.,^[106] Fraser^[107] and in wind energy systems, as well as in production systems, for example, with supervisory control and data acquisition (SCADA) in Feng et al.,^[108] Crabtree et al.,^[109] García Márquez et al.^[110] Despite the monitoring, gear load carrying capacity calculation is established and part of the international standard ISO 6336.^[111] Technologies to save time and costs by the evaluation of lifetime described by the load-carrying capacity are explained, for example, by Hein et al.,^[101,112] and are part of the current research. Different failure situations are possible depending on the operation conditions, the gear design, and the chosen lubricant. According to Niemann & Winter,^[113] Fromberger et al.^[114] distinguishing the following gear damages is well established in research and application: i) pitting, ii) tooth root fracture, iii) scuffing, iv) sliding wear, v) micropitting, and vi) tooth flank fracture. Pitting, tooth root breakage, micropitting, and tooth flank fracture are characterized as fatigue damage which follows an S/N-curve behavior. Wear is a continuing damage with approximately linear damage progression under certain operating conditions. Scuffing is instantaneous damage that may occur during operation under load and speed if the lubricating film breaks down. The result of the failure may have different severity—a tooth root fracture causes most probably a failure of the gearbox whereas micropitting damage typically has a negative impact on the dynamics of the gearbox but can allow ongoing operation.^[113,114] The growing failure modes have high potential to be measured by monitoring systems and allow the integration of condition-based monitoring systems. Depending on the condition, operating parameters and maintenance can be selected to achieve life or operational objectives.^[104,112]

4.1.2. Characteristic Parameters on Sensor-Integrating Gears

Based on literature and experiences, general challenges for sensor-integrating gears can be divided by the following param-

eters: load-carrying capacity and connection to the shaft, sensor, and sensor technology, physical measurand (e.g., temperature, acceleration, eddy-current-sensor), sensor location, distribution of electrical components, energy supply, and wireless data transfer system. For a summarizing overview of sensor-integrating gears, please see **Table 2** in Section 5.4.

The authors have identified the following examples that can be categorized as sensor-integrating gears: i) Additively manufactured metal spur gear wheel with an integrated accelerometer;^[115] ii) case-hardened metal helical gear wheel with hall sensor, accelerometer, temperature sensor, and microphone inside;^[116] iii) plastic spur gear wheel with an eddy-current sensor in the teeth;^[117] iv) metal spur gear wheel with resistance sensors on the side;^[118] v) sensor-integrating metal spur gear with accelerometer on the side.^[119,120]

4.1.3. Load-Carrying Capacity of Sensor-Integrating Gears

The load-carrying capacity of the gears depends on the factors of selected material, heat treatment, gear design, and shaft assembly. There are solutions that are not comparable, because not every publication lists all the necessary properties and the parameters of the gears. Most information is given in the publication by Bonaiti et al.^[116] where the influence of the cavities and possible designs for integration are discussed in detail. The gear is case-hardened. Because of the drilling progress of the threads and holes, the shape of the cavities is limited to the typical shapes possible with mechanical drilling and milling processes. The idea of this paper is to use the high tooth root safety and lower the safety in a way that the desired operation is not or less limited, while the potential of the high tooth root safety can be lowered by introducing the cavities. More critical than the loads of the gear meshing in this application is the conical interference fit. It is used to attach the gear on the shaft because of high loads. As a result, the radial distance between the shaft and cavities has to be considered in order to reduce the stiffness and safety of the connection in such a way that a proper operation and assembly at the selected operation range are still possible, as displayed in **Figure 14**.

Binder et al.,^[115] Sridhar & Chana,^[117] Peters et al.^[119,120] use a feather key to fix the gears on the shaft. The feather key concentrates the stress of the interaction between the shaft and the wheel at a certain orbital position. As a consequence, the sensors can be placed at radial positions close to the shaft compared to interference-fit wheel connection. Solutions with a feather key

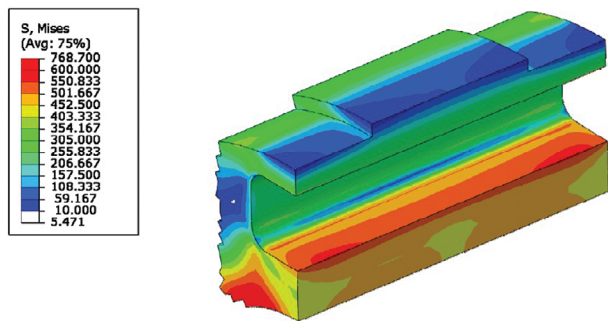

Figure 14. Von-Mises stresses, obtained from a finite element method simulation, to manage cavities and interference fit. Reproduced under the terms of the CC BY 4.0 license. Copyright 2022, by the authors licensee MDPI, Basel, Switzerland.^[116]

have a high load concentration at the feather key in the circular direction. So, for the circular positions with a certain distance to the feather key, integration is possible compared to interference fit.

4.1.4. Sensing Possibilities on Sensor-Integrating Gears

Binder et al.,^[115] Peters et al.^[119,120] selected acceleration sensors to measure the condition. Vibration-based monitoring is widespread in the condition monitoring of gears for example, in Tiboni et al.,^[121] Feng et al.,^[122] Sendlbeck et al.,^[105] Fromberger et al.^[114] The main sources of gear vibration under operation are mounting, manufacturing deviations, and the time-varying stiffness according to Fromberger et al.,^[114] Götz et al.^[123] When a fault occurs, additional vibrations caused by the fault can be measured. With the processing of the accelerometer data, failures and their type and severity can be estimated.^[105,122]

Generally, the most-used acceleration sensors can be divided into two types that are suitable for integration: The classic piezoelectric sensors, which have been used for gear monitoring for many years by Sendlbeck et al.,^[105] Fromberger et al.,^[114] Fan & Li,^[124] and micro-electro-mechanical systems (MEMS) sensors. The MEMS accelerometers have a typical seismic mass inside the sensor. Caused by vibrations the mass gets moved. This is measured by a piezoelectric or capacitive measurement principle. MEMS sensors are widespread because of their comparable low costs and application in many modern consumer goods such as smartphones, wearables, and cars. Bogue,^[125] Binder et al.,^[115] Peters et al.^[119,120] use both MEMS acceleration sensors. Peters et al.^[120] compared the sensor (STMicroelectronics IIS3DWB) with a piezoelectric sensor (PCB-356-06A2). The results showed that the MEMS sensor had a better signal-to-noise-ratio (SNR) compared to the piezoelectric sensor. Acceleration measurements of both sensor types are shown in **Figure 15**. Other advantages of MEMS sensors are the low costs and the low impedance of the signal compared to piezoelectric sensors.^[126,127] To avoid a disturbance of the electric signal, piezoelectric sensors have typically an integrated electric piezoelectric (IEPE) system.

The eddy-current sensor of Sridhar & Chana,^[117] Chana et al.^[128] can also detect the severity and classify damages. It is assembled in the teeth of a plastic idler gear wheel and is able to measure the shape of the teeth of the mating steel gear pinion. By comparing the signals of current teeth with historic ones, data

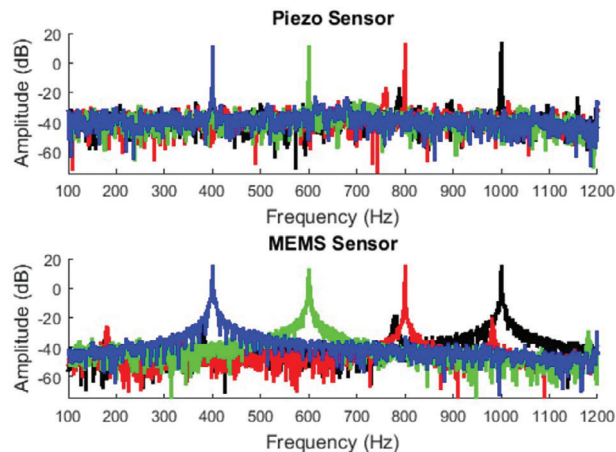

Figure 15. Comparison of different accelerometer types for gear monitoring by Peters et al. Reproduced under the terms of the CC BY-NC-ND 4.0 license. Copyright, 2021 The Authors. Published by Elsevier Ltd.^[120]

changes in the shape can be detected. Artificial damages have been tested to ensure the functionality of the sensors. How these damages are comparable to damages out of the running investigation has not been proven. Sridhar & Chana^[117] apply them to validate his system. An advantage of this sensing system is that there are not so many steps in signal processing and there is not so much knowledge required on vibration monitoring, frequencies, and signal processing. However, because of the use of a plastic gear wheel and contact between the wheels by Sridhar & Chana,^[117] a damage to the plastic wheel is much more likely, and load-carrying capacity is very limited compared to the case-hardened steel gears.

The resistance sensors by Mac et al.^[118,129] are the third sensor solution to discuss. This solution is able to detect different gear failures possibly better than the other sensor concepts. While acceleration and eddy-current sensors concentrate on monitoring surface damages such as scuffing, pitting, micropitting, and sliding wear, the resistance sensor focuses on the fracture damages to detect cracks. Due to the setup, a focus is set on the implementation of experimental data into the signal processing to be able to predict cracks.

4.1.5. Distribution of Electric Components

To maintain the properties of the gear the distribution of the electric components is also of interest for gear purposes. The gear wheel is typically under load and not purpose-designed for sensor integration as in Binder et al.^[115] Here, good integration even for existing gear geometry is possible due to the freedom of shaping enabled by additive manufacturing. **Figure 16** shows the integration of the electric components by Binder et al.^[115] without the need for additional space.

Another integration process without the need for additional sensors is made by Bonaiti et al.^[116] As shown in **Figure 17**, not only the integration of accelerometers has been investigated. A thermocouple hole has been calculated to be able to measure temperatures close to the tooth contact. The axial cavities house the other sensors, like accelerometers, and electronic components,

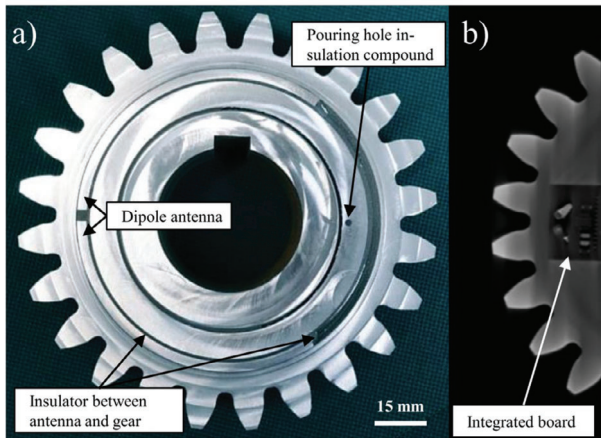

Figure 16. Integration of electronic components by Binder et al.^[115] Reproduced under the terms of the CC BY-NC-ND 4.0 license. Copyright, 2022 The Authors. Published by Elsevier B.V.

like microcontrollers. To connect all sensors with the microcontrollers, grooves are made in the gear wheel.

Peters et al.^[119,120] integrated the microcontroller and the energy supply on the shaft, not directly in the gear wheel. This solution typically provides more space for all components except the sensors. The disadvantage is that there has to be enough space on the shaft for this setup. Typically, this is less difficult for spur gears, where no axial forces are transmitted between the bearing and the gear wheel.

Sridhar & Chana^[117] placed all components on a circled printed board at the side of the gear wheel. So, no cables are required to connect the components of the system, like microcontroller, sensors, and others. The data from the sensor is preprocessed on the gear wheel with the Texas Instruments CC2650 microcontroller.

4.1.6. Energy Supply and Wireless Data Transfer

Binder et al.^[115] and Mac et al.^[129] use radio frequency wireless energy and data transfer. The hardware setup by Binder et al.^[115] is shown in **Figure 18**. With 868^[115] and 300 MHz,^[129] both use carrier frequencies in the ultra-high-frequency (UHF) range, allowing smaller antennas, higher data rates and transmission ranges compared to 13.56 MHz high-frequency (HF) or 125 kHz

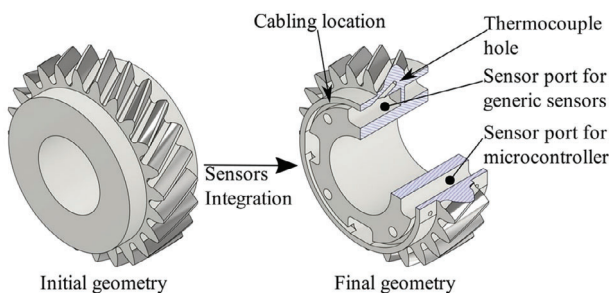

Figure 17. Integration of electronic components by Bonaiti et al. Reproduced under the terms of the CC BY 4.0 license. Copyright, 2022 by the authors. Licensee MDPI, Basel, Switzerland.^[116]

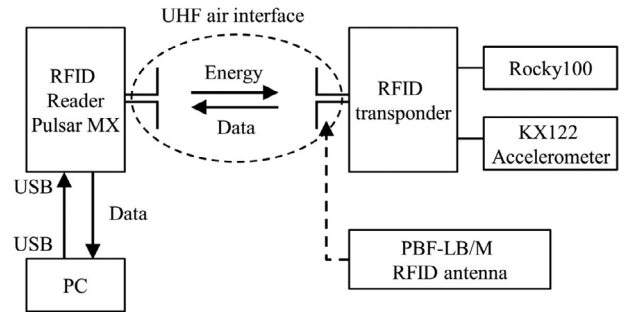

Figure 18. Hardware layout by Binder et al. with RFID. Reproduced under the terms of the CC BY-NC-ND 4.0 license. Copyright, 2022 The Authors. Published by Elsevier B.V.^[115]

low-frequency (LF) radio-frequency identification (RFID) technologies which need a close inductive coupling but offer a more efficient power transfer.

Sridhar & Chana^[117] selected Bluetooth to transfer the data. The data is sampled with 1 kHz and the data rate is typically limited by the energy consumption or the wireless data transfer protocol. As an energy supply, Sridhar & Chana^[117] selected a button cell battery that should empower the system for three years. To have enough space, the batteries are assembled on the other side of the gear compared to the side where the board is attached. Peters et al.^[120] also use batteries. The capacity is selected at 500 mAh. The lithium-ion battery should empower the system for more than 1000 h with an operating strategy where the system is 5 min per hour at measuring and in sleep mode for the remaining 55 min.

4.2. Shaft-Hub Connection

Shaft-hub connections (SHC) are important joints in gearbox design, as shown in **Figure 19**. In order to detect a failure of the SHC at an early stage and to record the applied loads, it is possible to integrate sensors into these connections. The design of the connections is standardized according to for example, DIN 7190-1,^[130] DIN 6892,^[131] DIN 5480-1,^[132] ISO 4156,^[133] but research on sensor-integrated SHC is still limited to a few projects. Worth mentioning are the patents by Gandrud,^[134] Bader,^[135] Groche & Traub^[136] as well as the works of Vogel et al.,^[137] Bonaiti et al.,^[116] Khan et al.,^[138] Golinelli et al.,^[139] Min et al.,^[140] Persson & Persson,^[141] Seltmann et al.^[142]

Groche as well as Bader describe a feather key (FK) to measure torques. In the first patent, Groche & Traub^[136] a FK is described, which consists of two vertical crossbars connected with a transverse crossbar. The profile is either H-shaped or N-shaped. The sensors, designed as strain gauges or piezoelectric sensors, are applied to the transverse crossbar. Bader^[135] describes a prismatic FK with continuous recesses and slots, where overloads are determined by deformation, but the transmission of the applied torque should not be hindered.

In the numerical feasibility study by Vogel et al.,^[137] the influence of the fits between shaft and hub as well as between shaft notch and FK is examined. When interference occurs in the notches between shaft and hub, and shaft and FK, only a part of the torque is transmitted directly via the FK; there are

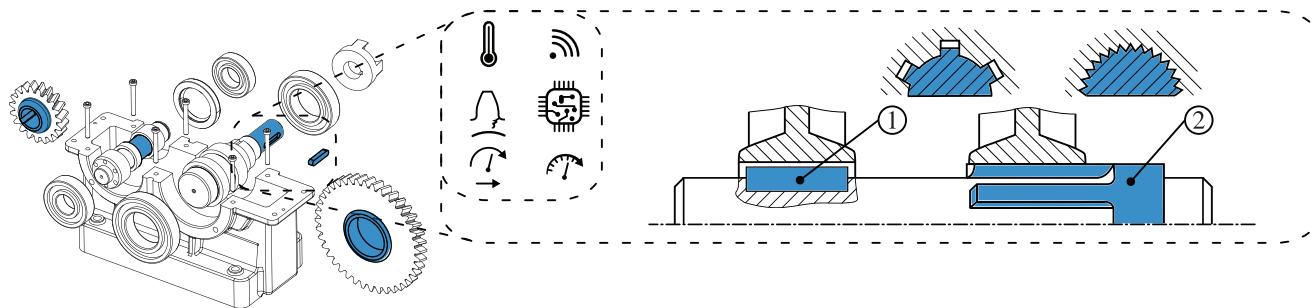

Figure 19. Sensor-integrating gear box, focusing on sensor-integrating shaft-hub connection and their measuring task exemplified by a key (1) and a spline shaft (2).

significant differences in the stress distribution compared to the ideally manufactured FK connection (FKC). This is also observed on an FKC with two FKs facing each other.

Seltmann et al.^[142] developed a FK for measuring the circumferential force by means of topology optimization, where the main dimensions are based on DIN 6885.^[143] The main idea is as follows: The FK is normally subjected to a non-uniform surface pressure, which, in addition to the torque, also depends on the hub geometry, resulting in a complex deformation of the FK. In order to determine the resulting circumferential force from this deformation field, the deformation of the FK must be measured with a large number of strain gauges. This is followed by complex calculations to determine the resulting circumferential force. With the aid of topology optimization, however, the geometry of the FK is adapted so that it always deforms approximately according to a linear combination of a few deformation modes under different non-uniform surface pressures. This reduces the number of strain gauges required to the number of deformation modes and simplifies the calculation of the resulting force. The boundary conditions were simplified for the topology optimization. For testing under practical boundary conditions, the geometry of the stiffness conditioned FK was simplified and a finite element model was created, as shown in **Figure 20**. For showing differences in pressure distribution dependent on the hub geometry two different cases are simulated. A torque is applied, and the deformation of the FK in the numerical model is studied. It is shown that the deformation can be described by a linear combination of two deformation modes, so the deformation of the FK should be measurable by applying two strain gauges.

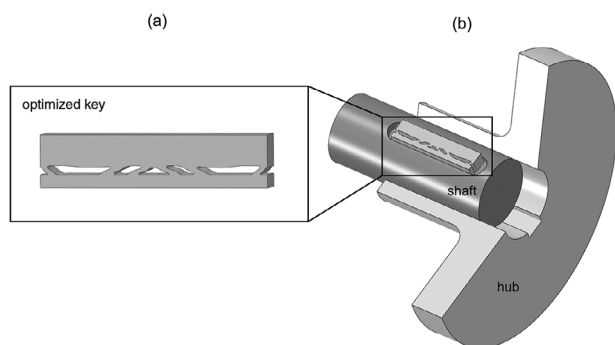

Figure 20. a) Interpreted stiffness conditioned feather key. b) Entire assembly for the finite element model.

For splined shafts, Khan et al.^[138] have developed a sensor for measuring the torsion about an axis, which is called a square-cut-torque-sensor (SCTS). The SCTS is a kind of hub with a significant decrease in stiffness (refer to Section 1.3), a similar sensor type was used by Min et al.^[140] Golinelli et al.^[139] worked out a torque sensor for the PTO of an agriculture gearbox. It should have high linearity, symmetry, scalability, and easy mounting of the strain gauges. Both analytical and numerical investigations were carried out to optimize the geometry. On the SCTS, strain gauges are applied, which can measure the torque of the SHC. SCTS is not directly integrated into the shaft (refer Section 1.3), it is a kind of coupling with sensor elements (load washer or pin), which is located inside the gearbox. Gandrud^[134] invented a magnetoelastic torque and speed sensor for use in hydraulic power units. He used the splined shaft itself as a sensor and minimized by this design, the loss of stiffness. Caused by the special and sometimes expensive materials of the magnetically active region, it is common to install a ring of the appropriate material on the shaft. The receiving sensor part is located in the housing of the hydraulic unit, so no additional wireless communication is necessary. Persson & Persson^[141] used a similar design space on a free shaft surface between two bearings. They evaluated different kinds of sensor principles with a focus on low costs and robust design, finally they preferred the magnetoelastic polarized band like Gandrud.^[134] This sensor arrangement needs a free shaft surface, which is not always available, so that in SHC more integrated solutions are the aim of further research work. Persson & Persson^[141] evaluated also the eddy current displacement sensor, which offers a peak hold function without energy consumption,^[144] which might be a useful feature in long term condition monitoring.

4.3. Seal Rings

Seals are used to separate (typically fluid) media and keep them confined to specific areas. They prevent the transport or mixing of media through this barrier. **Figure 21** shows schematically the use of sensor-integrating seals and their measuring task. Typically, they seal a gap between two or more separate parts. Since those parts and the associated media also play an important role in the sealing function, the sealing system is considered to consist of the seal itself, its tribological counter-surface and the sealed media. Depending on whether there is predominantly a relative motion between those parts during operation, seals are

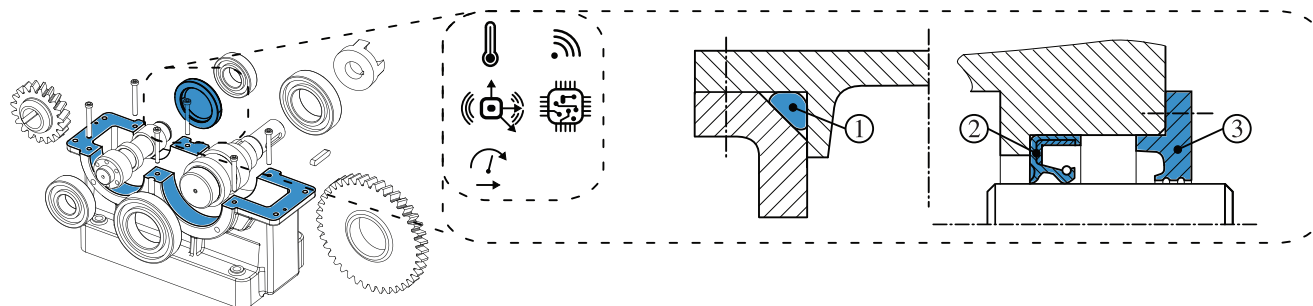

Figure 21. Sensor-integrating gear box, focusing on sensor-integrating seal and their measuring tasks exemplified by a static seal (1), a seal ring (2), and a labyrinth seal (3).

classified into static and dynamic seals.^[145] Typical examples of static seals are O-rings, rings with alternative sections (e.g., X- or D-rings), cylinder head or flange gaskets, or profile seals used in windows or doors. Those seals are considered to be static seals since there is no relative motion in the typical operation state of the seal. Dynamic seals include rotary seals such as lip seals, mechanical seals, clearance/labyrinth seals, special seals like magnetic fluid seals and also reciprocation seals for hydraulic and pneumatic applications such as piston or cylinder seals or diaphragm/bellow seals.

While static seals typically work by blocking a gap between the two volumes to be sealed, dynamic seals either work by limiting the amount of leakage by creating narrow, long gaps that impede fluid passage or by imposing active sealing mechanisms within the sealing gap where the relative movement occurs. These sealing mechanisms transport fluid back toward the sealed cavity.

Most seals fail due to a variety of reasons, including unfavorable design of the adjoining parts (surfaces, tolerances, etc.) or operating conditions, incompatibilities with the sealed media, contamination, and wear. This fact complicates the development and application of service life calculations for the majority of the mentioned seals types.^[146] Consequently, no reliable methods for estimating seal service life exist for most of the commonly used seal types. Depending on the type and size of the seal, the cost can range from several cents to many thousands of dollars. However, the majority of seals used in technical applications are comparatively low cost machine elements. Nevertheless, without properly functioning seals, machines fail. This means that for most seals, the cost associated with an unexpected failure is much higher than the cost of the seal itself,^[147] since the failure can lead to downtime, disproportionately high maintenance and even damage to other machine components if it is not detected soon or even prevented before it occurs.

The possible consequences of undetected seal failure have led to attempts at condition monitoring and the integration of sensors into various sealing systems. As a consequence of the generally low cost of most seal types, many attempts of commercialization of sensor-integrating seals have failed in the past due to the disproportionately high additional costs. One example of such a sensor-integrating seal is a rotary shaft seal with integrated leakage detection, which was briefly sold by the manufacturer.^[148,17] While this specific product is only intended to serve as an example, it also illustrates that the successful commercialization of a seal with additional sensor features has to offer the customers enough additional value to justify the increased cost.

The following sections aim to provide an overview of various attempts at integrating sensor functions in different sealing systems. The presented cases include some examples that were technically and commercially successful, but also examples of unsuccessful attempts or concepts that were only developed for research purposes. In doing so, it aims at providing the reader with an overview of the current state of sensor integration in different sealing systems.

4.3.1. Static Seals

The sealing function of static seals depends on the correct alignment and compression of the seal to ensure that the elastic seal material is sufficiently pressed to the sealing surface. This ensures that the percolation channels between the seal and surface stay closed, even at the operating pressure differential across the seal. Consequently, most attempts at sensor integration into static seals aim at monitoring the contact pressure, compression, and structural health of the seal.

One of the first published attempts at sensor integration in static sealing systems was done by Abushagur^[149] in 1994. By placing an optical fiber between an O-ring and its groove and using an unloaded fiber as a reference, he used the change in polarization and also the phase delay in the loaded fiber to determine the contact pressure. A similar approach by Krutz et al.^[150] used an embedded sensor architecture with insulated conductive layers on the top and bottom of the O-ring forming a capacitor that changes its capacitance with axial preload/compression, cuts, punctures, and also due to incompatibility (swelling). Cobb^[151] filed a patent for a gasket with an enclosed load sensor, consisting of confronting electrodes, and a pressure sensitive electrically resistive material. A further method for detecting compression in rubber using either carbon fiber^[152] or carbon nanostructure^[153] filled rubber materials that change their conductivity when compressed or stretched. These materials were used to develop “smart” intrinsically self sensing seals (O-rings^[153] and tubular seals^[152]) enabling the monitoring of compression levels. Using electrodes embedded in an O-ring, researchers were able to detect crevice corrosion in seawater piping.^[154–156]

4.3.2. Rotary Shaft Seals

Rotary shaft seals are dynamic seals in radial contact with the cylindrical shaft surface. They inflict a sealing mechanism on the

lubricant during relative motion (shaft rotation). Since the sealing lip is made of rubber, it is sensitive to wear, chemical lubricant interaction, and contact temperature.

The first attempt at integrating sensors in a sealing system with rotary shaft seals was pursued by Lines et al.^[157] He placed a resistance thermometer on the shaft surface near the contact region with the sealing lip to measure the contact temperature in the sealing contact. Shortly thereafter, Upper^[158] placed thermocouples in lateral slits inside the sealing lip itself for the same purpose. The placement of the sensors in the sealing lip proved to be sub-optimal, since they failed after several hours of seal operation. The method by Lines et al.^[157] or similar approaches are still being used today for research purposes. There are also attempts to integrate a similar measurement system into a special shaft sleeve that additionally provides wireless signal transmission.^[159]

Heinzen^[160] filed a patent for a seal with embedded wires that are shorted by contact with the shaft surface when a certain wear depth on the seal is reached.

Freudenberg Sealing Technologies GmbH sold a special rotary seal (MSS1+) that was using a special nonwoven material to absorb leakage and thereby change its optical properties, which were being detected by an optical sensor.^[148,17] The MSS1+ is currently not commercially available anymore. However, the company still offers a special device (not integrated in a sealing system) that can detect leakage using the same principle in any desired location.^[161] Several seal manufacturers furthermore offer special rotary shaft seal modules that provide shaft speed measurements using magnetized rubber or similar encoder elements on the shaft and a magnetic sensor inside the seal module.^[162,163]

Thielen et al.^[164] presented the idea of integrating a variety of sensors and wireless energy and data transmission capabilities in a rotary shaft seal, including thermocouples in the sealing edge and oil, a pressure sensor, strain gauges at the seal membrane for friction torque measurement and also a miniaturized IR emitter-sensor pair for measuring the IR-spectrum of the lubricant to be sealed.

4.3.3. Reciprocating Seals

Reciprocating seals typically seal moving pistons and rods in hydraulic and pneumatic applications or translational valves.

Similar to the Heinzen's approach to wear detection in rotary shaft seals, several reciprocating seals with conductive wear detection exist.^[165–169] In contrast to Heinzen's idea, these seals are made from a conductive elastomer and an insulating outer layer, allowing to detect a change in conductivity with wear progress.

Zhu et al.^[170] presented a method for measuring the oil film thickness between a reciprocating O-ring and a cylindrical housing using an ultrasonic transducer attached to the housing.

4.3.4. Mechanical Face Seals

Mechanical face seals consist of a rotating seal ring and a stationary mating ring that are pressed together using a spring and hydraulic forces. They are typically used in pumps, mixers, or compressors. Compared to other seal elements, they are more costly and often require maintenance. This justifies the use of sensors in mechanical face seals.

Similar to the work of Zhu et al.,^[170] Reddyhoff et al.^[171,172] used ultrasonic transducers to measure the fluid film height between the seal ring and mating ring. In very simple laboratory experiments, Gupta & Peroulis,^[173] Gupta et al.^[174] used an inductor-capacitor circuit with a temperature-sensitive capacitor or a permanent magnet with a temperature-sensitive magnetic field in combination with a Hall sensor to measure the face temperature in the sealing contact.

The sensor applications in mechanical face seals presented above are all research prototypes. However, the catalogs and brochures of mechanical face seal manufacturers also mention commercially available variants with sensors for temperature, pressure, and vibration.^[175]

4.4. Couplings

Couplings are mechanical elements that connect two shafts in order to transmit mechanical power from one to the other. Furthermore, they i) can compensate for shaft misalignment, ii) have a switching function to interrupt or limit the power flow, and iii) compensate for shocks.^[5,176] The industry provides a variety of application-specific design, which satisfy diverse requirement profiles. VDI 2240 provides a suitable basis for selecting and classifying couplings according to their requirements. A subdivision is made according to switchable (clutch) and non-switchable (couplings) couplings.^[177] Based on this classification, different possible measurement quantities result. For couplings, the measured variables of a torque and rotational speed are particularly relevant. Furthermore, temperature, wear, shaft misalignments, restoring and reaction forces, and vibrations can be significant. For clutches, which also includes brakes, the measurement of the same parameters is desirable. Additionally, relevant parameters are clutch engagement and slip between the two hubs. **Figure 22** displays three selected non-switchable couplings for the sensor-integration, for example, a sleeve coupling, a bellow coupling, and an elastic jaw coupling.

Schorck et al.^[178] proposed two concepts for sensor-integrating not shiftable, flexible, interlocking couplings: i) a helical beam coupling for the measurement of shaft misalignments and ii) a concept for an elastic jaw coupling. The advantage of the helical beam coupling for sensor integration is the fact that it has a relatively large installation space for the electronics due to the cavity, which is even partially capsuled. The hubs are connected through a bending plate which lies in the line path of the force. This plate is then placed in the unused space inside the deformable helical beam. If the hubs are misaligned the bending plate is deformed but virtually no force is transmitted via the plate, which means that the stiffness of the coupling is not changed. By applying strain gauges on the plate the deformation can be measured. Schork et al.^[178] found that angular displacement can be reliably measured, whereas radial displacement can only be determined inadequately. For the elastic jaw coupling, they integrated a bending plate, with applied strain gauges in one tooth of the gear rim, in order to measure the deformation of the tooth. For this reason, however, the modified tooth transmits almost no more forces, which leads to an increased load on the non-modified teeth and a reduction in the overall stiffness. However, the deformation is the same for all teeth, so it can be measured and used to calculate

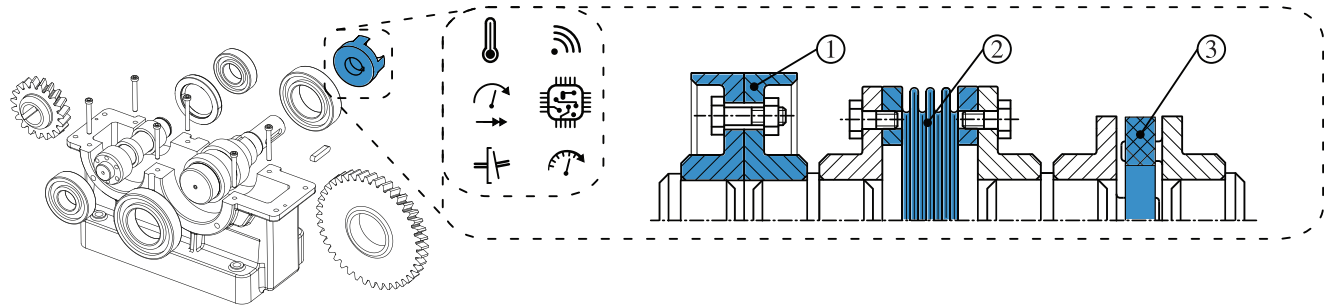

Figure 22. Sensor-integrating gear box, focusing on sensor-integrating couplings and their measuring task, exemplified by a sleeve coupling (1), a bellow coupling (2), and an elastic jaw coupling (3).

the torque and radial displacement. The measurements show the expected results, but are prone to errors due to creep and the nonlinear stiffness of the elastomeric material.

Menning et al.,^[179] Ewert et al.,^[180] Prokopchuk et al.^[181] have outlined a concept for a sensor-integrating elastic jaw coupling, that will be able to measure torque, rotational speed, temperature, and misalignments. They have integrated a new soft dielectric elastomer sensor (DES) into a borehole in the tooth of the elastic gear rim, cf. **Figure 23**.

The DES is placed between two amplifiers made of harder material in order to increase its relative deformation and for protection against external interference. This integration process preserves the teeth's ability to transmit forces, while reducing the transmittable torque of each tooth by only a small amount. If a load is applied, the tooth and therefore the DES are deformed. Based on the amount of deformation, the electrical capacitance of the DES changes. The capacitance can then be used to calculate the transmitted torque based on finite element method (FEM) models by Menning et al.^[182] for the coupling. The internal structure of the DES is further described in Prokopchuk et al.^[183] It is designed as an alternating stack of conductive-ink layers as electrode material, an Elastosil foil as dielectric material, and a conductive-ink layer as electrode, leading to several capacitors connected in parallel.

Jung et al.^[184] proposed a concept for measuring the torque in an automobile with a manual transmission. They utilized the linear behavior of the damper springs inside the clutch plate, which follows Hooke's law. Therefore, with knowledge of the deformation of the springs, the applied torque can be determined. The deformation was not determined directly but via evaluating the angular displacement between the clutch hub and the friction plate. This angular displacement was measured via a pick-up sensor, which is a non-contact sensor. Small posts are placed on the

i) friction plate and ii) clutch hub. The time interval between the pulses produced by the passing of the posts of the i) friction plate and ii) the clutch hub over the sensor is recorded. Via the ratio of the time intervals between two pulses from the clutch hub, and the interval between a clutch hub post and a friction plate post, the angular displacement of the clutch hub to the friction plate can be determined. With the known angular displacement the torque can be calculated via multiplication with the spring stiffness. The sensor-integrating transmission was tested in a road test in a passenger car and proved to measure the torque accurately and to be very sensitive.

4.4.1. Use of Smart Materials

Lee et al.^[185] proposed a magnetorheological elastomer (MRE) flexible coupling whose torsional stiffness can be adjusted for low frequencies. With this adjustable stiffness, the disturbances, that occur due to the excitation of natural frequencies during the use of a machine, can be reduced. The stiffness of the MRE, which is based on a combination of a silicon elastomer (Ecoflex) and carbonyl iron particles (CIP), can be adjusted via the magnitude of the magnetic field which in turn changes the overall stiffness of the coupling. The coupling has a built-in magnetic field generator which can generate up to 150 mT. Syam et al.^[186] proposed a coupling which uses the same principle.

Barik et al.^[187] reviewed the use of shape memory alloys such as nitinol as a material for couplings instead of steel due to their for example, superelasticity, vibration damping features, and better thermal stability. They explored the use of nitinol in the past where it was dominantly used in the military and explained the working principle of shape memory alloys as well as the explanation of shape memory alloy couplings.

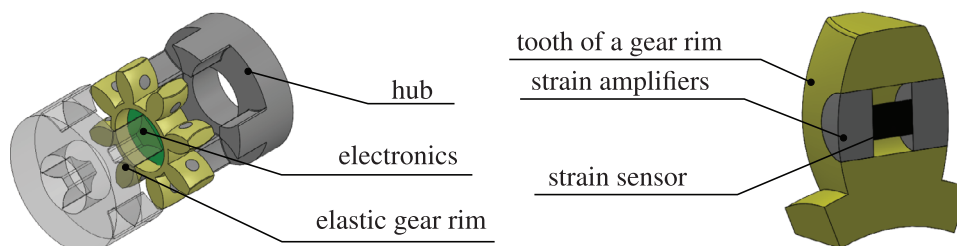

Figure 23. Concept of a sensor-integrating elastic jaw coupling using a dielectric elastomer sensor.

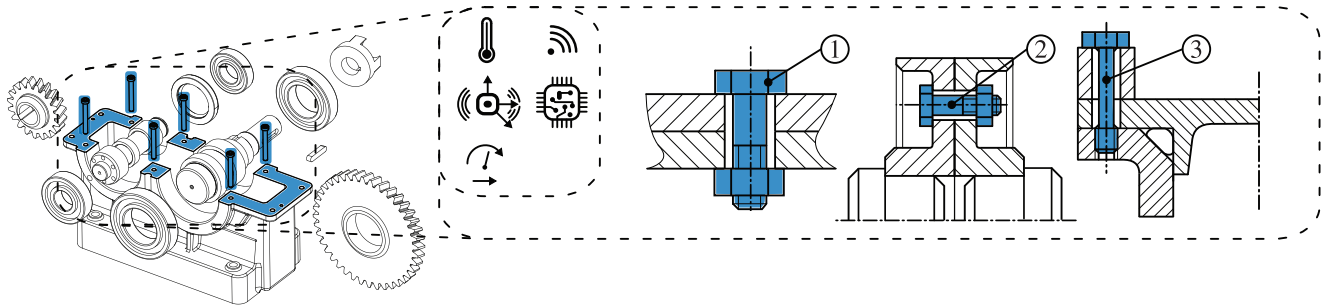

Figure 24. Sensor-integrating gear box, focusing on sensor-integrating screws and their measuring task exemplified by a single-bolted joint (1), a bolted flange (2) and a reduced-shank bolt (3).

Magnetorheological (MRF) fluids are another type of smart material which is often used in clutches and brakes. The ability of these fluids to rapidly change viscosity when exposed to a magnetic field makes them ideal for use in clutches.^[188,189] Phu & Choi^[190] have provided a brief overview of the use of MRF brakes and clutches in the period from 2013 to 2018 in their work.

4.4.2. Frictional Clutches

Another special case are wet-running steel disc clutches in marine gearboxes. Schneider et al.^[191] presented different concepts for condition monitoring of a multi-plate frictional clutch of a marine gearbox. They developed four concepts for the measurement of the wear and decided to adopt the concept in which the thickness of the disc set of the clutch is measured. The disc set will become thinner during the lifespan of the clutch due to abrasion and chemical processes. Other concepts that they described were i) to measure the quality of the oil, as it will deteriorate due to wear, ii) to measure the amount of oil required to compress the blades of the clutch, or iii) to measure friction vibrations. The authors chose a magnetic-inductive displacement sensor. To implement the sensor, the clutch had to be structurally modified. Under laboratory conditions the change in thickness of the disc can be measured in the order of 1 mm.

4.5. Screws

Screws or bolt connections are particularly suitable for the integration of sensor technology, as they are in the flow of forces^[192] and are among the most common component connections.^[193] **Figure 24** shows possible measuring tasks for sensor-integrating screws which are exemplified by a single-bolted joint, a bolted flange and a reduced-shank bolt.

Screws and screw connections are standardized in terms of design and dimensioning in several standards and guidelines (e.g. DIN 13-1,^[194] VDI 2230 Blatt 1: 2015-11^[195]). The load on a screw is usually multiaxial.^[192] During conventional assembly of screws, transverse forces act on the screw due to the torsional load, and during operation, safety-relevant bending and shear stresses occur in the head area,^[196] which act on the screw in addition to the axial pretensioning force. However, this is reduced to a uniaxial load in the systematic calculation of highly stressed bolted joints according to VDI 2230 Blatt 1: 2015-11^[195] by using

strength hypotheses and correction factors. In order to be able to better capture the entire spectrum of loads acting on a bolted connection, a multi-axial force measurement is necessary. This also enables process monitoring with early fault detection.

Existing sensor-integrating screws can be categorized according to the following points:

- i) measured physical quantities;
- ii) sensor principle and location;
- iii) data acquisition and transmission; and
- iv) impact on mechanic functionality

These points are emphasized in the following analysis of the state-of-the-art and summarized in Table 2.

In general, many solutions exist that measure the uniaxial preload force on the screw, based on the piezoresistive and resistive effect. For this purpose, the sensor element is inserted at various points in the shaft or head.

The CiS Research Institute for Microsensors in cooperation with the Department of Measurement and Sensor Technology uses piezoresistive silicon strain gauge elements.^[197] This enables measurement of the bolt preload force both statically and dynamically. Measurements of up to 100 kN with M16 and M48 screws are presented. The sensors do not reduce the screw's resilience. However, the electronics used to evaluate and transmit data are mounted externally on the screw head, needing more installation space. The energy supply and data transmission are carried out by means of RFID communication, so that a distance of a few centimeters can be bridged wirelessly.

The technology demonstrator Smart Screw Connection of Fraunhofer CCIT addresses energy self-sufficiency.^[198] The required energy can be obtained via solar cells or via a thermogenerator with a specially developed voltage converter. A thin-film sensor system (DiaForce) is used as the measuring element, integrated into a washer. This thin-film sensor system has a piezoresistive sensor layer for measuring the preload force and a meander structure made of chromium for measuring the temperature. Changes in the measured pressure impact on the sensor layer are an indicator for a loosening of the screw. The pressure areas in the sensor layer are read out sequentially by a 16-bit analog-to-digital converter (ADC) via a multiplexer, integrated in a small printed circuit board (PCB) to be mounted on the side of the sensor washer. In Biehl et al.,^[198] only axial forces are used to determine the accuracy of the system, which is 1% of the full scale range (433 MPa). In Fraunhofer-Institut



Figure 25. Sensor-integrating screw—M20; with kind permission of ConSenses GmbH.

für Schicht- und Oberflächentechnik IST^[199] a washer is described for a M18 screw with a maximum force of 150 kN. The determined measurement data are transmitted wirelessly via low power wide area network (LPWAN). However, the integration into the screw is not neutral to the installation space and therefore especially retrofitting is problematic.^[199]

In addition to the research demonstrators, commercial sensor-integrating screws (PiezoBolts) from the company ConSenses in sizes M6 to M20 and sensor systems for integration in cylindrical open machine elements such as shaft couplings from the company Core Sensing are available. In the PiezoBolts, piezo rings are pressed into a measuring body by means of a forming process^[200] and thus enable uniaxial dynamic force measurement.^[192] The requirement for space neutrality and simultaneous load-bearing capacity compared to conventional bolts is fulfilled.^[201] However, the power supply and data transmission are wire-bound via a plug connection at the screw head, see **Figure 25**.

Herbst et al.^[202] presented a force sensor for measuring axial forces and bending moments inside a bolt. The sensor is designed to fit inside a cavity of a diameter of 12 mm in a M20 screw, minimized to reduce the bolt's resilience by the equivalent of one strength class. Six strain gauges are used in pairs as half-bridges on the deformation body to produce three output signals. The decoupling capability has been proven with a maximum error of 3.1%. Linearity errors are low at $\pm 0.4\%$ and $\pm 1.1\%$ for axial and bending loads, respectively.

Multi-axial force measurement is currently only offered by the sensor systems from Core Sensing, which are also pressed into semi-finished products by forming processes. In addition, the temperature, acceleration, axial force and torque are recorded. Data is transmitted wirelessly via bluetooth low energy (BLE). The energy supply is realized by an integrated energy storage. Running times of up to one year can be achieved before the energy storage needs to be recharged. Alternatively, the energy supply can be cable-connected. However, the sensor systems are designed for usage in shafts with boreholes having inner diameters of 14 mm or more,^[94] thereby weakening the screw body and reducing usability.

Sensors were integrated into concrete fasteners by Horn et al.^[203] The focus is on finding the design space for the integration of the sensor into the flow of forces without compromising the primary function (load carrying capacity). A methodology, called ASTra by the authors, focusing on analysis and synthesis activities to overcome observational barriers and validate

solutions was used to address these significant interdisciplinary challenges. By identifying and modifying structures not relevant to the function, the design space for the sensor was found without weakening the fastener. External data acquisition electronics were connected to the sensors by wires.

Similar to the approach mentioned above, Sensorise GmbH offers the SmartScrew which can measure axial forces only without weakening the screw. It uses a thin wire in the thread ground as a strain gauge. However, it needs to connect to an external bridge amplifier via wires to obtain the measurement values.^[204]

In summary, it can be said that although fastening screws with integrated sensors are already available, most of them only permit uniaxial measurement of the screw pretensioning force or weaken the screw. As a result, it is often not possible to adequately determine the operating state of the machine in which the sensor is integrated. The limitations are also particularly evident in the area of energy supply for the systems presented, so that operation over the service life of the machine element is not given. Both the cable-based systems from CiS, ConSenses, and Core Sensing and the self-sufficient sensor screw from Fraunhofer CCIT can only be used in easily accessible places and are therefore not suitable for all installation conditions.

4.6. Roller Bearings

Figure 26 shows possible measuring tasks for sensor-integrating bearings exemplified by a roller bearing and a plain bearing. The integration of sensor systems is still in focus of ongoing research and based on the experience of past research projects.

4.6.1. Sensor-Integrating Rolling Element Bearings

Sensors for machine elements, especially for rolling bearings, were advanced for example, by previous work in Hanover in the 1980s. For example, experimental work using sputtered thin-film sensors with a resistance measurement method measured the pressure and temperature in the elastohydrodynamic (EHD) rolling contacts of a twin-disk test rig and cylindrical roller bearing. This work provided important knowledge for the processes in EHD contacts.^[205,206] However, these sensors were not used for continuous monitoring. In 1998, Gao et al.^[207] presented a concept for sensor integration of a piezoelectric vibration sensor coupled with microelectronics and a condition monitoring system (CMS) in a helicopter roller bearing. This approach of integrated sensor technology for online condition monitoring was validated by Holm-Hansen and Gao using a deep groove ball bearing equipped with an integrated sensor system consisting of a piezoceramic force sensor and evaluation unit.^[208] Bearing condition monitoring and observation of lubrication conditions using integrated bearing sensors were investigated by Marble & Tow.^[209] They developed a temperature and motion sensor for use in the cage of a rolling element bearing used in satellite pulse/reaction wheels. Shahidi et al.^[210] have taken a similar approach, using a capacitive sensor and induction coil in a roller bearing cage to detect vibration and temperature. Shahidi et al.^[211] equipped a rolling bearing with vibration, speed, and temperature sensors that were applied directly on—and not integrated into—the bearing. Scott et al.^[212] developed a bimorph

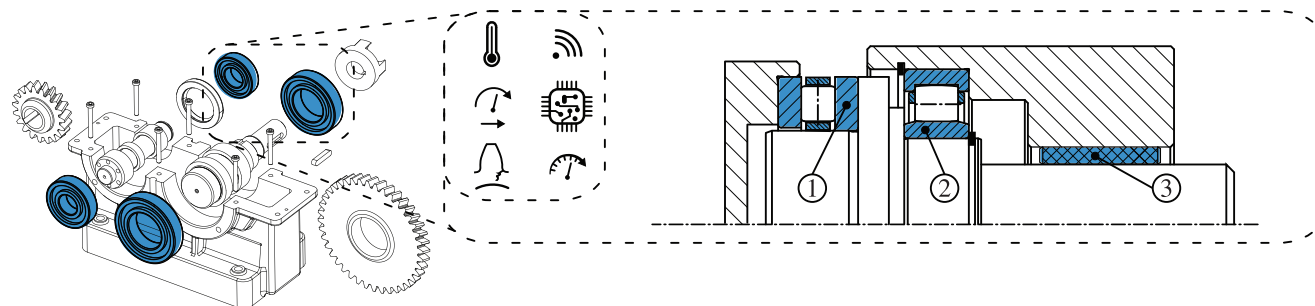

Figure 26. Sensor-integrating gear box, focusing on sensor-integrating bearings and their measuring task exemplified by a axial roller bearing (1), a radial roller bearing (2), and a plain bearing (3).

MEMS temperature sensor integrated into a rolling bearing and validated it in use at up to 2500 rpm. The development of sputtered pressure and temperature sensors in bearing applications has recently been addressed by a number of research groups. For example, Albers et al.^[213] conducted twin-disk tests using sputtered thermocouples. DLC (diamond-like-carbon) protective coatings were used for wear protection.^[213] Emmrich et al.^[214,215] also followed this approach and deposited thin-film sensors on rolling bearing components to investigate mixed lubrication conditions. Vogel & Kirchner^[216] dealt with sensor integration in machine elements and showed the possibilities of integration in existing systems. The integration of sensors is especially interesting for large size bearings consisting of hybrid materials to investigate the performance and draw conclusions about the mechanical connection and fatigue. Such tailored bearings are currently being developed within the Collaborative Research Centre 1153 “Process chain for the production of hybrid high-performance components through tailored forming.”^[217,218]

The shown sensors can be divided in those which measure outside of the tribological contact and those that measure directly in the tribological contact. For the latter, a maximum of information can be derived even though the integration of sensors is more difficult. Here, thin-film sensors are used due to their component inherent behavior with a minimal height of less than 10 μm .^[219] Thus, they are the only possible solution to generate measurement data directly at the EHD rolling contact without influencing the machine system. Due to their polymer-free layer stack, they can measure at higher operating temperatures^[219] and have improved high dynamic properties compared to conventional polymer, foil-based strain gauges. They can also have higher strain sensitivities, depending on the sensor material, and the sensor layout can be adapted to the individual use case. In addition, they can also be applied on curved metallic surfaces.^[220] The sensors can be used to measure physical quantities or operating conditions locally in machine components. In addition to monitoring the components, this also enables their targeted control with the inclusion of tribologically relevant measured variables. For example, mixed lubrication conditions and insufficient lubrication can be measured much faster in gear drives or rolling bearings by recording temperatures directly on the running surface than by measuring the temperature on the outside of the housing. In particular, the potential of thin-film strain gauges is investigated by Konopka et al.^[221] Used and evaluated intelligently, they could provide valuable information on slip, tangential forces, and normal forces in the rolling contact, for example in order to detect

critical operating conditions at an early stage so that a control system can intervene quickly. Through an innovative sensor-data fusion of differently aligned strain gauges and a temperature sensor, an interpretation of the sensor data concerning elastic strain, plastic deformation and temperature can be made.

At points of tribological loading, such as on the running surfaces of large-diameter roller bearings, it can be used both to record critical dynamic load conditions in real time and to identify and quantify degradation processes for the long-term behavior. At the same time, this is a deliberate break from conventional application regulations for commercial sensor technology, according to which, for example, surface-applied strain gauges can only be used within narrow tolerances with regard to strain, temperature, and mechanical loads. But the main disadvantage is their thickness due to the polymer carrier foil and adhesive so that they cannot be used in the EHD rolling contact.

The contact zone between roller and bearing surface has to be recorded resolving the deformations under the Hertzian contact stress. Therefore, a high requirement for the measurement technology is necessary. The measurement data of the sensor nodes are to be acquired by decentralized intelligent data pre-processing with high accuracy and high sampling rates, then pre-processed with regard to relevant information concerning the operating state and forwarded to a higher-level CMS. Figure 1 depicts the concept of sensor integration into large size machine elements for condition monitoring.

It is essential to create a fundamental understanding of the interlocking of the information flow from the machine element, that is the rolling bearing (with the data recorded in the elastohydrodynamic lubricated (EHL) contact between bearing raceway and bearing rollers), to the integration in a condition monitoring system (CMS). The application potential of the thin-film sensor technology is to be systematically explored in areas exposed to high tribological stress. Konopka et al.^[221] applied successfully the first prototypes on thrust cylindrical roller bearings and investigated them from a tribological point of view. These sensors were set up on axial bearing washers, as shown in Figure 27.

The prepared samples consist of three strain gauges (named Sg 0°, Sg 45°, and Sg 90°) that were applied to the bearing surface by using cathode sputtering. Constantan ($\text{Cu}_{54}\text{Ni}_{45}\text{Mn}_1$) was used as the sensor material. The electrical insulation of the sensor as well as wear protection is achieved by using aluminum oxide (Al_2O_3). Under tribological stress in a pin-on-plate tribometer, the resistance change was successfully measured. Taking into account the determined k -factor from previous studies^[222]

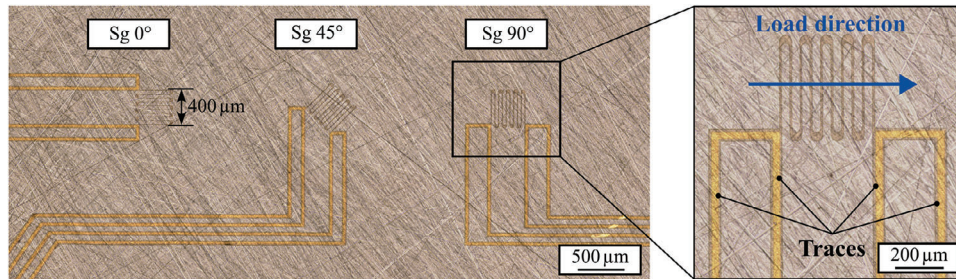

Figure 27. Microscopic image of a produced strain gauge array^[221] with permission from SMART2023 Conference. Copyright, 2023 The Authors. Published by Eccomas Proceedia.

and resistance changes in the range of -0.1% , strains of up to $60 \mu\text{m m}^{-1}$ were measured in the sliding contact as a result of a Hertzian pressure of 950 MPa. In the future, the focus will continue to be on the wear behavior within the stressed zone and an integrated temperature sensor. This approach is one way to expand the existing methods for sensor integration and monitoring of bearings.

4.6.2. Electrical Behavior of Rolling Contacts

This subsection summarizes the recent improvements of the current state of research in the area of the sensory behavior of rolling contacts.

First, the damaging effects of electric currents on rolling element bearings was described in numerous scientific papers dating back to the early 20th century when rolling bearings failed in tramway applications. Bethke and Barz calculated the lubrication film thickness based on the measured capacitance of rolling element bearings.^[223,224]

With the recent push toward electric mobility, the problem of damaging currents gained increasing importance in rolling bearing research. During the last decade, the models became more and more elaborate and tried to capture not only the area of hydrodynamic lubrication conditions with an insulating lubricant film but also mixed and dry friction modes as sketched in **Figure 28** with increasing likelihood of metallic contact. The general approach is in most of the models to represent the rolling bearing with its passive behavior in an electric circuit as a capacitor,

$$C_{\text{Hz}} = \epsilon_0 \times \epsilon_{\text{Lubricant}} \frac{A_{\text{Hz}}}{h_0} \quad (1)$$

Equation (1) assumes the Hertzian contact of the rolling element bearing to behave electrically like a plate capacitor with area A_{Hz} , lubrication film thickness h_0 and with the relative permittivity of the lubricant $\epsilon_{\text{Lubricant}}$, ϵ_0 being the electrical field constant. Due to the limitations of the simple model (1) in comparison with a real rolling element bearing, a couple of approaches modify the capacitance model (1) by either introducing additive or multiplicative corrections to better fit the model prediction to the capacitance measured.

The shortcomings of the phenomenological model (1) accompanied by measurements by Jablonka et al.^[226] gave rise to include also the contributions of the unloaded rolling contacts in the capacitance network of a rolling bearing.^[23,227]

In the context of the digitization of industry, the demand on data of technical systems and processes is on a constant rise especially for rolling element bearings.^[228] As stated above, the bearing's capacitance and therefore impedance depends on the lubrication film thickness and the Hertzian area. An increasing load acting on the rolling element bearing causes the lubrication film thickness to decrease and the Hertzian area to increase. Both effects contribute to an increase of the capacitance and decrease of the electric impedance as a sensory effect which can be measured by contacting the outer and inner race of a rolling bearing. The resulting sensory rolling bearing is a sensory utilizable machine element, cf. Section 1.3. Rolling element bearings are widely used in many rotating and reciprocating machines and allow even for the option of retrofitting sensory functions in existing machines, requiring as a modification in many cases just the isolation of at least one bearing ring and an electric connection to the rotating ring, for example, via a slip ring.^[225] Furthermore, the oil temperature needs to be measured whereas the shaft's rotational speed can be determined from the impedance signal transferred into the frequency domain.^[229]

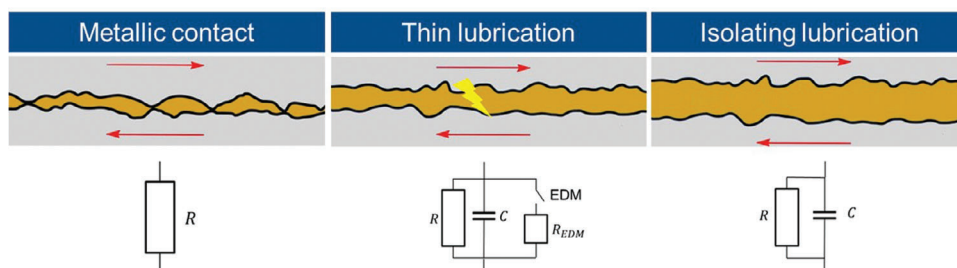

Figure 28. Electrical model of the EHD contact as a function of the lubricant film thickness (from Schirra et al.). Reproduced under the terms of the CC-BY-NC license. Copyright, 2022 the authors.^[225]

An indispensable requirement for the idea of a sensory utilizable rolling element bearing is the understanding and modeling of all relevant influencing factors on the electrical properties.^[230] In the late 1950s, the capacitive model served as the base to measure the lubrication film thicknesses of rolling contacts in order to develop formulas that allow a reliable prediction of rolling bearing's lubrication condition, see for example, Lewicki^[231] and Crook.^[232] Capacitive lubrication film thickness measurements are since then utilized for the analysis of steel on steel contacts in the EHD regime.^[226,227,233] Initial studies were conducted to better understand, model and predict the behavior of rolling bearings.^[23,234–236,239] The improved electric modeling of rolling element bearings enables their sensorial use.^[239,238] Monitoring of the operational load on rolling element bearings enables a reasonable estimation of the remaining useful lifetime and improves the sustainable use of these machine elements. Failure monitoring based on the electric impedance can furthermore reduce the risk of downtime due to premature failure.^[239]

4.7. Plain Bearings

Besides roller bearings, plain bearings are the most frequently used machine elements in mechanical engineering, which enable the relative movements of machine parts to each other. An advancing bearing damage and subsequent failure of a bearing can have serious consequences for the entire system in which the machine element is embedded in. Bearing failures are one of the leading causes of downtime and economical loss in drive train systems. For instance, approximately 60% of wind turbine downtime is caused by damage to gearboxes, with bearing damages leading to failure in 67% of gearbox failure cases.^[240] For large ship engines, damaged main bearings, including subsequent crankshaft damage, are by far the largest cost factor for propulsion system repair, at 1.8 million USD per appearance.^[241] The effects of bearing damage are serious in economic terms as well as in terms of safety. Consequently, condition monitoring of bearings is becoming increasingly important to minimize the downtime. Plain bearings are characterized by having a longer service lifetime and higher load capacity at equivalent dimensioning compared to roller bearings.^[242] Therefore, plain bearings are especially suitable for long-term and heavy-duty applications. Accordingly, roller bearings are increasingly being replaced by plain bearings in the planetary stages of wind turbine gearboxes.^[243] Additionally, first concepts of main drive trains with plain bearings in wind turbines have been published in Jonuschies,^[244] Rolink et al.^[245] In summary, significant challenges for the safe and economical operation of a drive train can be identified: The severe effects of bearing damage in drive train systems and the current development trends lead to higher loads resulting in more mixed friction operation as well as in an increased use of plain bearings in drive trains.

Plain bearing systems that utilize sensor technology in industrial applications are currently characterized by an external wired power supply as well as wired data transmission, which does not allow a practicable installation in multi-axis rotating system assemblies (e.g., planetary gearboxes in wind turbines). Valid condition monitoring methodologies are available, which

are suitable for sensor integration and in-situ measurement in plain bearings. Nevertheless, there are currently only few condition monitoring systems commercially available for plain bearings, where the sensor technology is integrated into the bearing volume. Commercially available systems from the manufacturers igus and NTN corporation are used for plastic plain bearings without the usage of a separating medium, which are suitable for applications with lower loads.^[246,247] The sensors were integrated into the bearing in the systems of the two manufacturers, while the measurement data is transmitted and the energy supplied by cable. The system of NTN measures the rotational speed using an integrated magnetic sensor, while the system of igus is capable of wear monitoring as well as calculating the remaining service life. However, the precise operating principle of the igus sensor system is not explained in detail.

Plain bearings, which are operated using a separating medium and therefore can enable wear-free operation, are classified into hydrostatic and hydrodynamic plain bearings. The friction and wear behavior of the surfaces moving relative to each other in hydrodynamic plain bearing is decisively dependent on their relative speed. Wear-free conditions are only achieved at sufficient relative speed. Hydrodynamic axial plain bearings, which primarily support axial forces in the direction of the shaft, are used less frequently compared to radial hydrodynamic plain bearings. Accordingly, the following section will focus primarily on hydrodynamic radial plain bearings and the possibilities for condition monitoring.

In the design of hydrodynamical radial plain bearings, the guidelines DIN standard 31652 and VDI standard 2204 represent established calculation methods for determining operational safe conditions.^[9,248] The calculation method is based on the hydrodynamic properties obtained from the numerical solution of the Reynolds differential equation. The hydrodynamic condition of complete separation of the surfaces by a lubricant film is sought in an iterative calculation model. The hydrodynamic and thus safe condition is reached once the minimum lubricant gap height h_{\min} is larger than a threshold lubrication gap height, which mainly depends on the surface roughness of the contact partners.^[249,250] The hydrodynamic condition ensures that there is no solid contact or mixed friction condition and thus no wear within the plain bearing. The bearing temperature represents another critical process variable in hydrodynamic plain bearings. As the temperature increases, the hardness and mechanical strength of the bearing material decreases. Due to their lower melting temperatures, the impact is particularly increased in the case of soft bearing metals. In addition, the viscosity of the lubricant decreases with increasing temperature. As a result, the load-carrying capacity of the plain bearing is reduced, which may lead to mixed friction causing wear. DIN 31652 -3 specifies temperature limits, which represent general empirical values.^[250] The relevant measured variable, which is compared with the limit values $T_{b, \lim}$, is the lubricant outlet temperature T_{ex} . However, longer-term or more frequent operation in the mixed friction area is not permissible according to the standards. Run-up processes are ensured by compliance to conservatively chosen thresholds for the sliding speed and specific pressure. Due to the specified limit values, the use of plain bearings in the operation of a wind turbine, for example, would presumably not be feasible according to the norm.

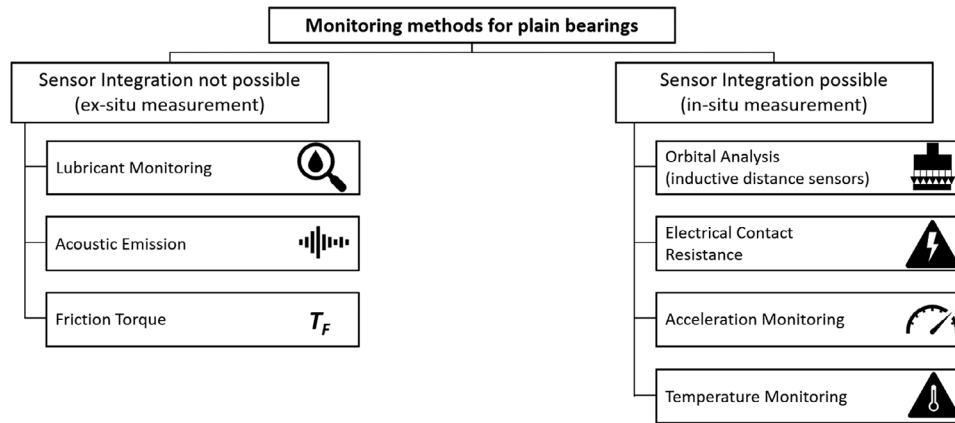

Figure 29. Condition monitoring methods for hydrodynamic radial plain bearings.

For monitoring these two relevant process variables in hydrodynamic radial plain bearings, measurement based on a variety of physical principles of effects is well established.^[251] However, not all of these options are suitable for sensor integration into the plain bearing. This section therefore provides an overview of which monitoring methods are suitable for sensor integration and which are not. Figure 29 displays condition monitoring methods for hydrodynamic radial plain bearings, categorized by suitability for sensor integration and by operating principle.

Examples of monitoring principles that are not suitable for sensor integration include lubricant monitoring, friction torque measurement, and acoustic emission analysis. Lubricant monitoring uses sensors to provide information on the number of metal particles in the lubricant as well as other characteristic values such as water content. If the plain bearing is not sufficiently lubricated, mixed, and solid body friction occur causing the release of particles from the plain bearing material. Established systems for lubricant monitoring use particle sensors in the oil tank, which provide information about particle contamination. Furthermore, the oil outlet temperature can be monitored accordingly to DIN 31652-3.^[250] However, due to the measurement positions, those concepts are not suitable for sensor integration in the machine element.

The occurrence of mixed or solid friction causes a change in the frictional torque or the frictional power. To determine these quantities, the torque emerging in the plain bearing needs to be determined, which is associated with a relative high effort or has to be determined indirectly from other measured variables. In most cases, only the total torque applied to the shaft can be measured outside the plain bearing volume.^[252] Therefore, the monitoring of the friction torque does not allow sensor integration for plain bearings.

Acoustic emission (AE) represents a condition monitoring method for early damage detection. Acoustic emission systems are based on the detection of sound waves that occur as a result of an abrupt energy release during structural changes, for example, crack formation. Using AE systems in the field of plain bearings, a successful assignment of the measurement signals to the present condition of lubrication was demonstrated.^[251,253–255] However, the practical implementation of AE-systems is facing significant challenges. An extensive application of AE-CMS is

not expected at the present time due to the required investment, pattern recognition, and data reduction. Furthermore, the sensors used are retrofitted to the support structure surrounding the plain bearing and cannot be integrated into the machine element.

Monitoring methods that enable sensor integration into the plain bearing include orbital analysis, electrical contact voltage measurement, acceleration monitoring, and temperature monitoring. In orbital analysis, the displacement of the shaft during operation is measured contactless. Three inductive distance sensors are placed flush with the running track of the bearing for the measurement. Based on the measuring signals, the radial motion of the shaft can be determined through triangulation. On the one hand, the changes in the shaft orbit over the running time of the system are measurable and thus the wear height can be determined. In addition, an indirect statement about the lubrication condition based on the geometry, the current position and the roughness values is possible.^[256,257] An implementation in industrial applications is mostly not feasible due to the high sensor costs.

An additional sensor-integrating condition monitoring option is the measurement of the electrical contact voltage between the shaft and the plain bearing.^[258,259] An electric potential is generated between the plain bearing and the shaft for this application. In the case of a hydrodynamic operation, an infinitely high resistance exists between the contact surfaces, as the lubricants used are usually non-conductive. Once the operating condition changes and metallic contact occurs, the resistance decreases rapidly, resulting in a current flow.^[258] The current flow enables information to be derived about mixed or solid-body friction conditions and the duration of these conditions. An industrial application however is not always feasible, as an insulation between the shaft as well as the plain bearing and the remaining components of the system is necessary.^[260] A commercially available condition monitoring system that utilizes the contact voltage as a measured variable is the Bearomos system from Schaller automation.^[261] However, in the Bearomos system, the sensor is attached to the shaft via an adapter and is not integrated into the plain bearing as is required for sensor integration.

Acceleration monitoring using piezoelectric acceleration sensors is a common method for monitoring machine elements, which is generally suitable for sensor integration. If the machine

elements are under load, mechanical vibrations are induced, which generate a force on the sensor. The force is converted into an electrical signal by the piezoelectric effect. Due to the proportional relationship between force and acceleration, the charge generated at the electrodes of the acceleration sensors is also proportional to the acceleration.^[262] Acceleration monitoring provides valuable information in particular for machine elements with periodically loaded contacts, for example, for gears or roller bearings, but is less suitable for continuously loaded contacts in hydrodynamic plain bearings. In the case of plain bearings, only advanced damages as well as cavitations could be detected by acceleration signals.^[253,254,263]

Temperature measurement within the plain bearing volume is the most frequently used monitoring method, which can be implemented with integrated sensors. During hydrodynamic operation, a temperature gradient to the ambient temperature is created by the fluid friction. The temperature in the load zone rises with an increasing proportion of mixed or solid friction due to insufficient separation of the surfaces.^[252] The temperature is measured as close as possible to the running track to ensure the maximal thermal sensitivity of the sensors. Possible positioning of the temperature sensors is presented in DIN 31692-2.^[264] However, in industrial applications, the temperature sensors cannot always be positioned directly at the load zone. As a result, the sensitivity of the temperature sensors to friction development is reduced. Consequently, damage cannot always be detected reliably or only at an advanced stage.

In summary, it can be stated that several valid measurement principles exist for plain bearings which are suitable for sensor integration. However, there are currently no commercially established condition monitoring systems for hydrodynamic radial plain bearing that operate with integrated sensors. Monitoring methods described in literature, which allow sensor integration into the machine element, transmit the measurement data and submit the needed energy by cable. A system that operates self-sufficiently in terms of energy and wirelessly transmits data does not exist to date. Accordingly, a need for research can be derived, which is being addressed in the DFG priority program 2305. The lubrication gap height could be determined by measuring the temperature field close to the bearings running surface.^[265] In ordinary load cases, the displacement angle of the shaft is directly correlated to the position of the temperature maximum on the running surface of the plain bearing. If the displacement angle is known, it is possible to calculate the lubrication gap height via the correlation of the DIN-standardized Gumbel curve.^[266] The Gumbel curve represents a numerical solution of the Reynolds differential equation for discrete values of the characteristic of interest, the relative eccentricity. If the bearing geometry is known, the minimum lubrication gap height can in turn be determined from the relative eccentricity. The temperature measurement data is processed and an interpolation algorithm using grid points of the Gumbel curve to determine the minimum lubrication gap height temperature-based is implemented. The microcontroller will be integrated into the plain bearing and the monitoring data is transmitted wirelessly. The energy for operating the system will be supplied by thermoelectrical harvesting utilizing the temperature gradients occurring within the plain bearing. A detailed concept description is presented in Marheineke et al.^[265]

5. Conclusions and Open Challenges

Before drawing conclusions on the maturity of development methods for sensor-integrating machine elements in general, cf. Section 3, and the concepts for the sensor-integrating machine elements in particular, cf. Section 4, a careful anamnesis has to be performed of the open challenges which interconnect the current research activities.

5.1. Common Open Challenges—Methodological Perspective

The methodological toolbox for the development and subsequent integration of sensor-integrating machine elements at the system level offers a good variety of methods for the selection of the measurement procedure, see Section 1.4, and for supporting the conceptual design of the machine elements themselves, see Section 3.1. Methods to analyze and improve robustness are available to a big extent, Section 3.2. The modularization of sensor modules is also being pushed forward, Section 3.3.

However, a white spot exists in the conceptualization of the sensor module itself considering environmental conditions and available packaging space in the machine elements and the interdependencies of the sensorial part functions described in Section 1.5.

5.2. Common Open Challenges—Technical Perspective

As described in the individual sections, the authors consider to the following five categories of research questions to be the main challenges to be solved for the different classes of sensor-integrating machine elements in particular and for their joint special research program in general:

- i) The *mechanical integrity* of the hosting machine element needs to be secured in order to maintain the primary function of the element in its design context.
- ii) The *energy supply* of the sensor module must be guaranteed considering its operational strategy which may include phases of hibernation to save energy. Cable or battery based concepts are less favorable because of the imposed limitations of integration or the need for exchange.
- iii) A *data storage* is required to avoid the necessity of permanent signal transfer which is considered energetically exhausting.
- iv) The *signal transfer* out of rotating components in an oily environment, which is electromagnetically encapsulated by for example, a housing structure, is difficult.
- v) Open questions regarding the *mechanical integrity* of micro-electronic components and the respective joining technology need to be solved including availability of durability data for example, in the form of Wöhler diagrams allowing for a proper dimensioning calculus.

5.3. Potential Directions for Future Research

To address the scientific and technical challenges mentioned above, the following research objectives will guide the next research steps:

Table 2. Properties of sensor-integrating machine elements—A comprehensive overview.

Machine element	Measuring task	Sensor element/ Input/ Output	Signal acquisition, Signal conversion, Signal transmission	Active element/ Active material	Energy supply	Model, simulation, experiment	Technology readiness	Boundary conditions	Literature, reference
Gear	Acceleration	Via microcontroller	Induction	No	Radio-frequency identification (RFID)	Technology tested but not in practical application	System test successful		Binder et al. ^[115]
Gear	Acceleration, noise, temperature, rotational speed	Via microcontroller	Cable	No	Battery and energy harvesting	FEM-simulation and gear dimension	Simulation successful, practical validation in the future	Oil lubrication and operating temperatures above +65 °C	Bonaiti et al. ^[116]
Gear	Tooth profile	Via microcontroller	Bluetooth	No	Battery	Technology tested in practical application	Tested in application on a test rig		Sridhar & Chana ^[117]
Feather key connection	Torque, force	Strain gauges, deformation	Wire	–	Wire	Simulation	Research prototype		Seltmann et al. ^[142]
Shaft-hub connection	Torque	Magneto elastic	Induction	–	Wire	Model	System test successful	Sensor-carrying system	Gandrud ^[134]
Fastener	Displacement	Capacitive / distance / voltage or dielectric / impedance	Transmission by BLE	–	Wire and storage, inductive	Experimentally tested and in practical application	TRL 9	No weakening of screw body	Horn et al. ^[203]
Static seal	Compression	Carbon nanostructure filled rubber	–	–	Wire	Experiment	Prototype		Periyasamy et al. ^[153]
Shaft seal	Temperature	Thermoresistive	Wire	–	Wire	Experiment	Research prototype		Lines et al. ^[157]
Shaft seal	Temperature	Thermoelectric	Wire	–	Wire	Experiment	Research prototype		Upper ^[158]
Shaft seal	Wear	Resistive / contacts short circuited by wear	Wire	–	Wire	Experiment	Research prototype		Heinzen ^[160]
Shaft seal	Leakage	Nonwoven with change in optical properties when wet / optical sensor	Wire	–	Wire	–	Commercial product		Stücheli & Meboldt, ^[17] Freudenberg Simrit ^[148]

(Continued)

Table 2. (Continued)

Machine element	Measuring task	Sensor element/ Input/ Output	Signal acquisition, Signal conversion, Signal transmission	Active element/ Active material	Energy supply	Model, simulation, experiment	Technology readiness	Boundary conditions	Literature, reference
Reciprocating seal	Wear	Electrically conducting rubber	Wire	–	Wire	–	Commercial product	–	Traber, ^[165] Freudenberg Sealing Technologies ^[166–168]
Reciprocating seal	Oil film height	Ultrasonic transducer	Wire	–	Wire	Experiment	Research prototype	–	Zhu et al., ^[170] Reddyhoff et al., ^[171,172] Schork et al., ^[178]
Coupling	Torque, shaft misalignment	Strain gauges/ deformation/ change in resistance	No data	No data	By wire	Prototype was manufactured	TRL 4	–	
Clutch	Torque	Pick-up sensor/ time signal/ displacement angle	Signal is demodulated and demultiplexed	No		Torque sensor system was incorporated in a vehicle	TRL 6	–	Jung et al., ^[184]
Clutch	Wear	Magnetic-inductive displacement sensor	Transmission wirelessly	No	Energy harvester with 200 mW for a period of one second	Experiments	Concept and first experiments conducted	–	Schneider et al., ^[191]
Screw	Force uniaxial–static and dynamic	Piezoresistive silicon strain gauge on screw head / deformation / resistance	Microelectronics for signal conditioning, amplification and transmission via RFID on screw head	–	RFID	Experiments conducted	TRL 4	Sensor and electronics on head not space neutral	CIS Research Institute for Microsensors Frank et al., ^[197]
Screw	Force uniaxial, temperature	Piezoresistive thin film sensor / deformation / resistance	Transmission (LPWAN)	–	Thermogenerator, solar cell	Experimentally tested and in practical application	TRL 9	Smart screw connection, not space neutral	Fraunhofer-Institut für Schicht- und Oberflächentechnik IST, ^[199] Biehl et al., ^[198]
Screw	Force uniaxial	Piezo based force sensor / deformation / resistance	Transmission by wire	–	Wire	Experimentally tested and in practical application	TRL 9	PiezoBolt, same load capacity as conventional screws, wire needed	Consenses GmbH ^[201]
Screw	Force uniaxial	Three strain gauges / deformation / resistance	Transmission by wire	–	Wire	Experiments conducted	TRL 5	Wire needed	Groche & Brenneis ^[192]

(Continued)

Table 2. (Continued)

Machine element	Measuring task	Sensor element/ Input/ Output	Signal acquisition, Signal conversion, Signal transmission	Active element/ Active material	Energy supply	Model, simulation, experiment	Technology readiness	Boundary conditions	Literature, reference
Screw	Force, torque multiaxial	Strain gauges / deformation / resistance	Transmission by BLE	–	Wire and storage, inductive		TRL 9	Other measurands with additional sensors like acceleration or temperature also recorded; requires borehole of 14 mm or more - weakens screw body	Core sensing GmbH ^[94]
Screw	Force uniaxial	Strain gauge / deformation / resistance	Wire	–	Wire	Experimentally tested and in practical application	TRL 9	No weakening of screw body, wire needed	Sensorise GmbH ^[204]
Ball bearing	Bearing load and speed	Capacitive / alternating current	No	No	Accumulator for analysis device	Technology proven, spin-off in operation	System test successful	Contact to shaft and bearing ring required	Schirra et al. ^[21,24]
Axial cylindrical roller bearing	Strain	Strain gauges / deformation / resistance	Wire	–	Wire	Experimentally tested	Tested in application on a test rig	–	Winkelmann et al. ^[267]
Radial bearing	Strain, force	Strain gauges / deformation	Wire	–	Wire	Simulation, experimentally tested	Prototype	–	Nässelqvist et al. ^[268]
Plain bearing	Wear		Transmission by wire	No	By wire		Commercial product	Wire needed; suitable for plastic plain bearings only	Igus ^[246]
Plain bearing	Speed	Magnetic rotation sensor	Transmission by wire	No	By wire		Commercial product	Wire needed; suitable for plastic plain bearings only	NTN global corporation ^[247]

- i) Considering the changed mechanical properties requires methods for predicting the performance and reliability of the machine element in different operating conditions when designing or using the SiME. For example the impact of the change in stiffness caused by the cavity needs to be considered on a system level, when for example, weakening a bolt, see Figure 25, leading to a reduction in the transmitted force.
- ii) Energy harvesting solutions need to be identified working under the environmental condition of a typical machine element to avoid cables for energy and data transfer limiting the applicability of the sensor-integrating machine elements and violating the requirements of standardized integration interfaces. As an example one may calculate the effective temperature difference usable for the thermoelectric effect in a plain bearing, cf. Section 4.7.
- iii) Estimation routines for the required data storage and the data processing capabilities for the different machine elements need to be established to facilitate the electric and electronic dimensioning being a main driver for the modularization and hence key to economic success. The same holds for the energy storage which is closely linked to the operational strategy. Currently, there is a lack of knowledge on how data amount and operational strategies influence the energy demand of sensor-integrating machine elements.
- iv) Data transfer and update capabilities need to be researched for sensor-integrating machine elements considering the typical operational eco-system which is governed often by oil dust and heavy steel walls surrounding the machine element in its operational environment shielding electromagnetic waves.
- v) Even though microelectronic components are widely used in customer products such as cellular telephone, there is little to none scientific data available on their generally tolerated mechanical and/or thermal load profiles beyond their current industrial applications. The harsh environment of machine elements requires reliable sensor modules. Research concerning these challenges is needed in robust and resilient electronic components and circuits to fulfill the measurement functions and operation under for example, harsh thermal conditions, electromagnetic fields and mechanical vibrations. This holds true also for the joining technologies under superimposed mechanical loads, which stress the electronic components in operation. Finally, the operation of the sensor modules may lead to electric losses causing a temperature increase; the thermal energy balance needs to be considered when selecting electronic components and assessing their durability performance.

This research roadmap calls for the development of new technologies and methods. This will be done in a number of interdisciplinary research projects.

5.4. Conclusions on the Conceptual Capability

The main characteristics of the various concepts for sensor-integrating machine elements described in this article are summarized in Table 2 as a key reference. The conceptual maturity is high on a systematic and methodological level, however,

many detail questions still need to be solved with the main challenges being summarized in Section 5.2. The authors strongly believe that the data acquisition through machine elements is a promising idea since it is the logical extension of the interface systems and exchange ability of machine elements (cf. Section 1.2) once the future development tasks outlined in the previous section are solved.

Acknowledgements

This research was funded by the Deutsche Forschungsgemeinschaft (DFG, German Research Foundation)—Project-ID 441853410, SPP2305. Responsibility for the content of the report lies with the authors.

Open access funding enabled and organized by Projekt DEAL. Correction added on 1 February 2024, after first online publication: Projekt Deal funding statement has been added.

Conflict of Interest

The authors declare no conflict of interest.

Author Contributions

E.K.: Conceptualization; resources; writing—original draft; writing—review and editing; project administration; supervision; and funding acquisition. T.W.: Conceptualization; resources; writing—original draft; writing—review and editing; project administration; supervision; funding acquisition. T.G.: Conceptualization; writing—original draft; writing—review and editing; project administration; supervision. J.D.M.M.: Conceptualization; writing—original draft; writing—review and editing; investigation. J.P.: Methodology; writing—original draft; investigation; data curation. R.B.: Writing—review and editing; visualization. B.K.: Investigation; writing—original draft. P.W.: Writing—original draft. J.K.: Writing—original draft, writing—review. D.K.: Funding acquisition; writing—original draft; writing—review. E.K.: Conceptualization; investigation; data curation; writing—original draft, visualization. M.O.: Conceptualization; writing—review and editing; visualization; supervision; funding acquisition. B.M.: Writing—original draft. S.S.: Writing—review and editing. A.H.: Funding acquisition; writing—review and editing; supervision; project administration. G.S.: Writing—original draft; writing—review and editing. A.L.: Funding acquisition; writing—review and editing; supervision; project administration. S.T.: Funding acquisition; supervision; project administration; writing—original draft; writing—review and editing. Y.S.: Writing—review and editing. O.K.: Writing—review and editing. A.E.: Writing—original draft; investigation; visualization. T.R.: Supervision; writing—original draft. B.S.: Supervision; funding acquisition; writing—review and editing. A.P.: Investigation; writing—review and editing. E.-F.M.H.: Funding acquisition; supervision; writing—original draft. F.H.: Investigation; writing—review and editing. D.R.: Investigation; writing—review and editing. F.K.: Project administration; supervision; writing—review and editing. S.M.: Conceptualization; funding acquisition; supervision; writing—review and editing. K.H.: Conceptualization; funding acquisition; supervision. F.P.: Conceptualization; resources; writing—original draft; writing—review and editing; project administration; supervision; funding acquisition. D.K.: Conceptualization; resources; investigation; writing—original draft; writing—review and editing. G.P.: Project administration; supervision; funding acquisition. T.S.: Conceptualization; investigation; writing—original draft, writing—review and editing. R.O.: Conceptualization; resources; writing—original draft; writing—review and editing. F.D.: Writing—review and editing; project administration; funding acquisition. M.C.W.: Project administration; supervision; funding acquisition. S.P.: Investigation; writing—review and editing. T.B.: Investigation; writing—original draft. M.W.: Investigation; writing—original draft. G.J.:

Writing—review and editing; supervision; project administration; funding acquisition. B.L.: Writing—review and editing; project administration. K.S.: Conceptualization; writing—review and editing; supervision; funding acquisition.

Keywords

development methods, machine elements, mechatronic systems, modularization, sensors

Received: July 21, 2023

Revised: October 20, 2023

Published online: January 28, 2024

- [1] DFG-SPP2305, DFG Priority Programme 2305, <https://www.spp2305.de/> (accessed: June 2023).
- [2] A. Harder, M. Hausmann, B. Kraus, E. Kirchner, A. Hasse, *Appl. Mech.* **2022**, *3*, 160.
- [3] W. Kloos, K.-H. und Thomala, *Schraubenverbindungen – Grundlagen, Berechnung, Eigenschaften, Handhabung*, Springer-Verlag, Berlin, Heidelberg **2008**.
- [4] H. Lechner, G. und Naunheimer, *Fahrzeuggetriebe*, Springer-Verlag, Berlin, Heidelberg **2007**.
- [5] B. Schlecht, *Maschinenelemente 1*, Vol. 2, Pearson Deutschland, Munich **2006**.
- [6] B. Schlecht, *Maschinenelemente 2*, Vol. 2, Pearson Deutschland, Munich **2010**.
- [7] Schaeffler Technologies AG Co. KG, *Wälzlagerpraxis – Handbuch zur Gestaltung und Berechnung von Wälzlagerungen*, Vereinte Fachverlage, Mainz **2015**.
- [8] H. Linke, *Stirnradverzahnung – Berechnung, Werkstoffe, Fertigung*, Hanser Fachbuchverlag, München **2010**.
- [9] G. Niemann, H. Winter, B.-R. Höhn, K. Stahl, *Maschinenelemente 1*, Springer, Berlin, Heidelberg **2019**.
- [10] B. Sauer, *Konstruktionselemente des Maschinenbaus 2 – Grundlagen von Maschinenelementen für Antriebsaufgaben*, 2nd ed., Springer Vieweg, Wiesbaden **2017**.
- [11] B. Sauer, *Konstruktionselemente des Maschinenbaus 1 – Grundlagen der Berechnung und Gestaltung von Maschinenelementen*, 1st ed., Springer Vieweg, Wiesbaden **2016**.
- [12] T. Rao, *Design of Machine Elements*, Vol. 1, 3rd ed., I.K. International Publishing House Pvt. Limited, New Delhi **2021**.
- [13] A. Ugural, *Mechanical Design of Machine Components: SI Version*, CRC Press, Boca Raton, FL **2018**.
- [14] T. Childs, *Mechanical Design: Theory and Applications*, Elsevier Science, Amsterdam **2021**.
- [15] B. Kraus, P. Welzbacher, J. Schwind, T. Hahn, E. Kirchner, *Procedia CIRP* **2023**, *119*, 272.
- [16] E. Kirchner, A. Hasse, M. Hofer, G. Jacobs, S. Puchtler, B. Schlecht, K. Stahl, M. Weigand, *Power Transm. Eng.* **2022**, *1*, 30.
- [17] M. Stücheli, M. Meboldt, in *Smart Product Engineering: Proc. of the 23rd CIRP Design Conf.*, Springer, Berlin **2013**, pp. 263–272.
- [18] G. Vorwerk-Handing, T. Gwosch, S. Schork, E. Kirchner, S. Matthiesen, *Forsch. Ingenieurwes.* **2020**, *84*, 21.
- [19] E. Kirchner, G. Martin, S. Vogel, *Presented at 23rd Int. Seminar on High Technology*, Piracicaba, Brazil, October **2018**.
- [20] G. Martin, S. Schork, S. Vogel, E. Kirchner, *Konstruktion* **2018**, *70*, 71.
- [21] Schaeffler-Technologies, <https://www.schaeffler.de/de/news-medien/mediathek/downloadcenter-detail-page.jsp?id=87412994> (accessed: February 2023).
- [22] G. Martin, S. Vogel, T. Schirra, G. Vorwerk-Handing, E. Kirchner, presented at, *DS 91: Proc. of NordDesign 2018*, Linköping, Sweden, August **2018**.
- [23] T. Schirra, G. Martin, S. Puchtler, E. Kirchner, *Tribol. Int.* **2021**, *158*, 106927.
- [24] T. Schirra, G. Martin, M. Neu, E. Kirchner, presented at, *USA: Society of Tribologists and Lubrication Engineers*, Nashville, Tennessee, May **2019**.
- [25] B. Kraus, S. Matzke, P. Welzbacher, E. Kirchner, in *DS 119: Proc. of the 33rd Symp. Design for X (DFX2022)*, Technical University of Darmstadt, Darmstadt **2022**, pp. 1–10.
- [26] B. Brinkmann, *Internationales Wörterbuch der Metrologie. Grundlegende und allgemeine Begriffe und zugeordnete Benennungen (VIM)*, Vol. 4, Beuth Verlag GmbH, München **2012**.
- [27] M. Hausmann, Y. Koch, E. Kirchner, *Int. J. Prod. Lifecycle Manage.* **2021**, *13*, 48.
- [28] M. Löpelt, P. Wilsky, J. Ruffert, N. Göhlert, R. Prielipp, R. Riedel, *Z. Wirtsch. Fabrikbetr.* **2019**, *114*, 273.
- [29] DIN 1319-1, *Grundlagen der Messtechnik - Teil 1: Grundbegriffe*, Deutsches Institut für Normung e.V., Berlin **1995**.
- [30] H. Czichos, W. Daum, in *Dubbel: Taschenbuch für den Maschinenbau* (Eds: K.-H. Grote, B. Bender, D. Göhlich), Vol. 25, Springer, Berlin, Heidelberg **2018**, pp W1–W37.
- [31] H. Czichos, *Mechatronik*, Springer Fachmedien, Wiesbaden **2019**.
- [32] R. Anderl, presented at, *Technological Innovations in the Product Development, 19th Int. Seminar on High Technology*, Sao Paulo, Brasilien October **2014**.
- [33] Evaluation of measurement data—Guide to the expression of uncertainty in measurement, Joint Committee for Guides in Metrology, Geneva **2008**.
- [34] ISO-IEC-GUIDE98-3, *Messunsicherheit - Teil 3 - Leitfaden zur Angabe der Unsicherheit beim Messen*, Beuth Verlag GmbH, Berlin **2008**.
- [35] R. Stark, R. Anderl, K.-D. Thoben, S. Wartzack, *ZZ. Wirtsch. Fabrikbetr.* **2020**, *115*, 47.
- [36] F. Carpi, D. De Rossi, R. Kornbluh, R. E. Pelrine, P. Sommer-Larsen, *Dielectric Elastomers as Electromechanical Transducers: Fundamentals, Materials, Devices, Models and Applications of an Emerging Electroactive Polymer Technology*, Elsevier, Amsterdam **2011**.
- [37] I. A. Anderson, P. Illenberger, B. M. O'Brien, in *Electroactive Polymer Actuators and Devices (EAPAD) 2016*, Vol. 9798, SPIE, Bellingham **2016**, pp. 104–111.
- [38] J. Han, N. Xu, J. Yu, Y. Wang, Y. Xiong, Y. Wei, Z. L. Wang, Q. Sun, *Energy Environ. Sci.* **2022**, *15*, 5069.
- [39] S. Priya, D. J. Inman, *Energy Harvesting Technologies*, Vol. 21, Springer, Berlin **2009**.
- [40] R. Vullers, R. van Schaijk, I. Doms, C. Van Hoof, R. Mertens, *Solid-State Electron.* **2009**, *53*, 684.
- [41] S. P. Beeby, M. J. Tudor, N. White, *Meas. Sci. Technol.* **2006**, *17*, R175.
- [42] B. A. Grohmann, T. Wallmersperger, B. Kröplin, *Stahlbau* **2000**, *69*, 446.
- [43] I. Chopra, J. Sirohi, *Smart Structures Theory*, Vol. 35, Cambridge University Press, Cambridge **2013**.
- [44] D. J. Leo, *Engineering Analysis of Smart Material Systems*, John Wiley & Sons, Hoboken, NJ **2007**.
- [45] M. Sobczyk, S. Wiesenhütter, J. R. Noennig, T. Wallmersperger, *J. Intell. Mater. Syst. Struct.* **2022**, *33*, 379.
- [46] D. Großkurth, L. Mennicke, K. Hofmann, in *Elektronische Baugruppen und Leiterplatten EBL 2022*, Vol. 375, DVS-Berichte, DVS Media GmbH, Düsseldorf **2022**, pp. 37–42.
- [47] H. Watschke, G. Marijn, J. Heubach, T. Vietor, K. Leichsenring, M. Böhl, *Appl. Sci.* **2021**, *11*, 113.
- [48] E. Kirchner, C. Bienefeld, T. Schirra, A. Moltschanov, *Machines* **2022**, *2*, 10.

- [49] A. Harder, E. Kirchner, in *Dresdner Maschinenelemente Kolloquium*, Sierke Verlag, Göttingen **2019** pp. 533–542.
- [50] A. Harder, H. Gross, G. Vorwerk-Handing, E. Kirchner, in *DS 109: Proc. of the Design Society: 23rd International Conf. on Engineering Design (ICED21)*, Design Society, Scotland **2021**, pp. 3359–3368.
- [51] J. Van der Weijde, *Ph.D. Thesis*, Technical University Delft Delft, The Netherlands **2020**.
- [52] Schaeffler Austria GmbH, Schaeffler VarioSense: Konfigurierbare Sensorlager für die Maschinen- und Prozessüberwachung, https://www.automation.at/bericht/lager/konfigurierbare_sensorlager_fuer_die_maschinen_und_prozessueberwachung-2017-02-07 (accessed: April 2023).
- [53] J. Mihm, C. Loch, A. Huchzermeyer, *Manage. Sci.* **2003**, 49, 733.
- [54] J. S. Gero, *AI Mag.* **1990**, 11, 26.
- [55] J. S. Gero, U. Kannengiesser, in *An Anthology of Theories and Models of Design* (eds: A. Chakrabarti, L. T. M. Blessing), Springer, London **2014**, pp. 263–283. https://doi.org/10.1007/978-1-4471-6338-1_13.
- [56] S. Matthiesen, in *Pahl/Beitz Konstruktionslehre* (eds: B. Bender, K. Gericke), Springer, Berlin, Heidelberg **2021**, pp. 397–465. https://doi.org/10.1007/978-3-662-57303-7_13.
- [57] K. Tahera, D. C. Wynn, C. Earl, C. M. Eckert, *Res. Eng. Des.* **2019**, 30, 291.
- [58] T. Gwosch, S. Matthiesen, *Machines* **2023**, 11, 3.
- [59] J. Peters, C. Zimmerer, T. Gwosch, F. Herbst, C. Hartmann, R. Chadda, D. Riehl, F. Keil, M. Kupnik, K. Hofmann, S. Matthiesen, in *DS 119: Proc. of the 33rd Symp. Design for X (DFX2022)*, The Design Society, Scotland **2022**, pp. 1–10.
- [60] VDI 2221 Blatt 2:2019-11, *Entwicklung technischer Produkte und Systeme: Gestaltung individueller Produktentwicklungsprozesse*, Beuth Verlag GmbH, Berlin **2019**.
- [61] VDI 2206:2021-11, *Development of mechatronic and cyber-physical systems*, Beuth Verlag GmbH, Berlin **2021**.
- [62] K. Hofmann, F. Keil, S. Matthiesen, T. Gwosch, M. Kupnik, E. Kirchner, D. Göhringer, M. Otto, K. Stahl, in *EASS* (Ed: O. Schrecker), VDE Verlag GmbH, Berlin **2022**, pp. 36–38.
- [63] G. Taguchi, S. Chowdhury, Y. Wu, *Taguchi's Quality Engineering Handbook*, Vol. 134, John Wiley & Sons, Inc., Hoboken, NJ **2005**.
- [64] M. E. Pfetsch, E. Abele, L. C. Altherr, C. Bölling, N. Brötz, I. Dietrich, T. Gally, F. Geßner, P. Groche, F. Hoppe, E. Kirchner, H. Kloberdanz, M. Knoll, P. Kolvenbach, A. Kuttich-Meinschmidt, P. Leise, U. Lorenz, A. Matei, D. A. Molitor, P. Niessen, P. F. Pelz, M. Rexer, A. Schmitt, J. M. Schmitt, F. Schulte, S. Ulbrich, M. Weigold, in *Mastering Uncertainty in Mechanical Engineering*, Springer International Publishing, Cham **2021**, pp. 365–456.
- [65] H. Juul-Nyholm, T. Eifler, M. Ebro, in *Proc. of the Design Society: DE-SIGN Conf.*, Vol. 1, Cambridge University Press, Cambridge **2020**, pp. 235–244.
- [66] O. Föllinger, F. Dörrscheidt, M. Klittich, *Regelungstechnik: Einführung in die Methoden und ihre Anwendung. 12. überarbeitete Auflage*, VDE Verlag, Heidelberg, Hühig **2016**.
- [67] P. Welzbacher, F. Schulte, M. Neu, Y. Koch, E. Kirchner, *Des. Sci.* **2021**, 7, e18.
- [68] P. Welzbacher, G. Vorwerk-Handing, E. Kirchner, *Proc. Des. Soc.* **2021**, 1, 51.
- [69] P. Welzbacher, S. Puchler, A. Geipl, E. Kirchner, *Proc. Des. Soc.* **2022**, 2, 653.
- [70] J. Mathias, H. Kloberdanz, R. Engelhardt, H. Birkhofer, in *DS 60: Proc. of DESIGN 2010, the 11th Int. Design Conf., Dubrovnik, Croatia*, The Design Studio, Scotland **2010**, pp. 341–350.
- [71] *Pahl/Beitz Konstruktionslehre* (Eds: B. Bender, K. Gericke), Springer, Berlin, Heidelberg **2021**.
- [72] F. Salvador, *IEEE Trans. Eng. Manage.* **2007**, 54, 219.
- [73] D. Krause, N. Gebhardt, *Methodical Development of Modular Product Families*, Springer, Berlin, Heidelberg **2023**.
- [74] R. Breimann, E. Kirchner, J. Küchenhof, *Dresdner Maschinenelemente Kolloquium - DMK 2022*, Sierke Verlag, Göttingen **2022**, pp. 79–92.
- [75] D. V. Steward, *IEEE Trans. Eng. Manage.* **1981**, EM-28, 71.
- [76] U. Lindemann, M. Maurer, T. Braun, *Structural Complexity Management: An Approach for the Field of Product Design*, Springer, Berlin **2009**.
- [77] T. U. Pimpler, S. D. Eppinger, in *6th Int. Conf. on Design Theory and Methodology*, American Society of Mechanical Engineers, New York City **1994**, pp. 343–351.
- [78] G. Erixon, A. von Ykull, A. Arnström, *CIRP Ann.* **1996**, 45, 1.
- [79] C. Askhøj, C. K. F. Christensen, N. H. Mortensen, *Concurrent Eng.* **2021**, 29, 221.
- [80] R. Anderl, M. Eigner, U. Sandler, R. Stark, *Smart Engineering: Interdisziplinäre Produktentstehung*, Springer-Verlag, Berlin, Heidelberg **2012**.
- [81] G. Barbieri, C. Fantuzzi, R. Borsari, *Mechatronics* **2014**, 24, 833.
- [82] F. Mhenni, J.-Y. Choley, O. Penas, R. Plateaux, M. Hammadi, *Adv. Eng. Inf.* **2014**, 28, 218.
- [83] C. Zheng, P. Hehenberger, J. Le Duigou, M. Bricogne, B. Eynard, *Res. Eng. Des.* **2017**, 28, 333.
- [84] T. J. Van Beek, M. S. Erden, T. Tomiyama, *Mechatronics* **2010**, 20, 850.
- [85] G. Schuh, C. Dolle, S. Barg, M. Kuhn, S. Breunig, in *2018 IEEE Int. Conf. on Industrial Engineering and Engineering Management (IEEM)*, IEEE, Piscataway, NJ **2018**, pp. 1391–1395.
- [86] C. Askhøj, M. Løkkegaard, C. A. Bertram, N. H. Mortensen, in *Balancing Innovation and Operation*, The Design Society, Scotland **2020**, pp. 1–12.
- [87] J. Küchenhof, M. C. Berschik, E. Heyden, D. Krause, *Proc. Des. Soc.* **2022**, 2, 495.
- [88] J. Küchenhof, C. Tabel, D. Krause, *Proc. CIRP* **2020**, 91, 796.
- [89] M. Zuefle, J. Küchenhof, M. Hanna, D. Krause, in *DS 121: Proc. of the 24th Int. DSM Conf. (DSM 2022)*, The Design Studio, Scotland **2022**, pp. 58–67.
- [90] F. M. Seiler, D. Krause, *Proc. Des. Soc.* **2020**, 1, 2405.
- [91] K. Otto, K. Hölttä-Otto, R. Sanaei, K. L. Wood, *J. Mech. Des.* **2020**, 142, 041402.
- [92] R. Breimann, M. Fett, J. Küchenhof, I. Gomberg, E. Kirchner, D. Krause, H. C. Trieu, *Proc. CIRP* **2023**, 119, 1041.
- [93] D. Wang, L. Fang, M. Xu, J. Yu, in *2011 IEEE Int. Conf. on Mechatronics and Automation*, IEEE, Piscataway, NJ **2011**, pp. 1109–1114.
- [94] Core Sensing GmbH, Datasheet corein, <https://core-sensing.de/app/uploads/2022/12/coreIN-core-sensing.pdf> (accessed: March 2023).
- [95] T. Touret, C. Changenet, F. Ville, M. Lalmi, S. Becquerelle, *Mech. Syst. Signal Process.* **2018**, 101, 197.
- [96] M. Elforjani, D. Mba, A. Muhammad, A. Sire, *Appl. Acoust.* **2012**, 73, 859.
- [97] Y. Lei, J. Lin, M. J. Zuo, Z. He, *Measurement* **2014**, 48, 292.
- [98] S. Al-Arbi, *Ph.D. Thesis*, University of Huddersfield, Huddersfield **2012**.
- [99] D. Vietze, M. Hein, K. Stahl, in *Verein Deutscher Ingenieure, 20th International VDI Congress Dritev 2020*, VDI-Berichte, VDI Verlag GmbH, Düsseldorf **2020**.
- [100] J. Pellkofer, M. Hein, T. Reimann, M. Hombauer, K. Stahl, *Forsch. Ingenieurwes.* **2019**, 83, 603.
- [101] M. Hein, T. Tobie, K. Stahl, *Forsch. Ingenieurwes.* **2017**, 81, 291.
- [102] N. Sagraloff, M. Hein, T. Tobie, K. Stahl, in *International Conference on High Performance Plastic Gears 2017*, VDI-Berichte, VDI Verlag, Düsseldorf **2017**, pp. 143–152.
- [103] P. Roth, M. Hein, K. Stahl, *Forsch. Ingenieurwes.* **2022**, 86, 503.
- [104] M. Fromberger, U. Weinberger, B. Kohn, T. Utakapan, M. Otto, K. Stahl, presented at 24th Int. Congress on Sound and Vibration 2017 (ICSV 24), International Institute of Acoustics and Vibration, London, July **2017**.

- [105] S. Sendlbeck, M. Fromberger, M. Otto, K. Stahl, in *27th Int. Congress on Sound and Vibration 2021 (ICSV27)* (eds: E. Carletti, M. Pawlcyk, M. Crocker, J. Tuma), Curran Associates, Inc., Red Hook, NY **2021**, pp. 1796–1803.
- [106] P. J. Dempsey, D. G. Lewicki, D. D. Le, in *2007 IEEE Aerospace Conf.*, IEEE, Piscataway, NJ **2007**, pp. 1–13.
- [107] K. F. Fraser, *An Overview of Health and Usage Monitoring Systems (HUMS) for Military Helicopters*, DSTO Aeronautical and Maritime Research Laboratory, Victoria **1994**.
- [108] Y. Feng, Y. Qiu, C. J. Crabtree, L. Hui, P. J. Tavner, in *Proc. of European Wind Energy Association Conf.*, European Wind Energy Association, Brussels, Belgium **2014**, pp. 17–19.
- [109] C. J. Crabtree, D. Zappala, P. J. Tavner, *Survey of Commercially Available Condition Monitoring Systems for Wind Turbines*, Durham University School of Engineering and Computing Sciences and the SU-PERGEN Wind Energy Technologies Consortium, Durham **2014**.
- [110] F. P. García Márquez, A. M. Tobias, J. M. Pinar Pérez, M. Papaelias, *Renewable Energy* **2012**, *46*, 169.
- [111] ISO 6336, *Calculation of Load Capacity of Spur and Helical Gears*, International Organization for Standardization, Geneva **2019**.
- [112] M. Hein, T. Tobie, K. Stahl, *Forsch. Ingenieurwes.* **2021**, *85*, 1091.
- [113] G. Niemann, H. Winter, *Maschinenelemente: Band 2: Getriebe allgemein, Zahnradgetriebe - Grundlagen, Stirnradgetriebe*, Springer, Berlin **2003**.
- [114] M. Fromberger, S. Sendlbeck, M. Rothemund, J. Götz, M. Otto, K. Stahl, *Forsch. Ingenieurwes.* **2019**, *83*, 521.
- [115] M. Binder, V. Stapff, A. Heinig, M. Schmitt, C. Seidel, G. Reinhart, *Proc. CIRP* **2022**, *107*, 505.
- [116] L. Bonaiti, E. Knoll, M. Otto, C. Gorla, K. Stahl, *Machines* **2022**, *10*, 888.
- [117] V. Sridhar, K. Chana, *Int. J. Prognostics Health Manage.* **2021**, *12*, 1.
- [118] T.-T. Mac, D. Iba, Y. Matsushita, S. Mukai, N. Miura, A. Masuda, I. Moriwaki, *Sensors* **2022**, *22*, 3231.
- [119] J. Peters, L. Ott, M. Dörr, T. Gwosch, S. Matthiesen, *Forsch. Ingenieurwes.* **2022**, *86*, 421.
- [120] J. Peters, L. Ott, M. Dörr, T. Gwosch, S. Matthiesen, *Proc. CIRP* **2021**, *100*, 672.
- [121] M. Tiboni, C. Remino, R. Bussola, C. Amici, *Appl. Sci.* **2022**, *12*, 2.
- [122] K. Feng, J. C. Ji, Q. Ni, M. Beer, *Mech. Syst. Signal Process.* **2023**, *182*, 109605.
- [123] J. Götz, U. Weinberger, F. Siglmüller, M. Otto, K. Stahl, in *Proc. of 27th Int. Congress on Sound and Vibration 2021 (ICSV27)* (Eds: E. Carletti, M. Pawlcyk, M. Crocker, J. Tuma), International Institute of Acoustics and Vibration, Auburn **2021**, pp. 1709–1716.
- [124] Z. Fan, H. Li, *Measurement* **2015**, *64*, 71.
- [125] R. Bogue, *Sensor Rev.* **2013**, *33*, 300.
- [126] D. Franke, *Wälzlagerdiagnose an Maschinensätzen: Diagnose und Überwachung von Wälzlagerfehlern und -Schäden*, Springer Vieweg, Berlin, Heidelberg **2022**.
- [127] Instructions on Measuring and Interpreting the Vibration of Machines—Typical Vibration Patterns with Machine Sets in Hydraulic Power Stations, Beuth Verlag GmbH, Berlin **2007**.
- [128] K. S. Chana, M. T. Cardwell, J. S. Sullivan, In *Proc. of ASME Turbo Expo 2013: Turbine Technical Conf. and Exposition*, American Society of Mechanical Engineers, New York City **2013**, pp. 1–11.
- [129] T. T. Mac, D. Iba, Y. Matsushita, S. Mukai, T. Inoue, A. Fukushima, N. Miura, T. Iizuka, A. Masuda, I. Moriwaki, *Forsch. Ingenieurwes.* **2022**, *86*, 433.
- [130] DIN 7190-1, *Pressverbände - Teil 1: Berechnungsgrundlagen und Gestaltungsregeln für Zylindrische Pressverbände*, Deutsches Institut für Normung e.V., Berlin **2017**.
- [131] DIN 6892, *Mitnehmerverbindungen ohne Anzug - Passfedern - Berechnung und Gestaltung*, Deutsches Institut für Normung e.V., Berlin **2012**.
- [132] DIN 5480-1, *Passverzahnungen mit Evolventenflanken und Bezugsdurchmesser - Teil 1: Grundlagen*, Deutsches Institut für Normung e.V., Berlin **2006**.
- [133] ISO 4156, *Passverzahnungen mit Evolventenflanke, Metrische Module, flankenzentriert Grundlagen*, Deutsches Institut für Normung e.V., Berlin **2005**.
- [134] M. Gandrud, *US20030172747A1*, **2003**.
- [135] A. Bader, *DE 10 2006 052 529 B4*, **2011**.
- [136] P. Groche, T. Traub, *DE102016110577A1*, **2016**.
- [137] S. Vogel, G. Martin, T. Schirra, E. Kirchner, in *DS 92: Proc. of the DESIGN 2018 15th Int. Design Conf.*, The Design Studio, Scotland **2018**, pp. 3033–3040.
- [138] H. Khan, M. D'Imperio, F. Cannella, D. G. Caldwell, A. Cuschieri, C. Semini, *Sensors* **2017**, *17*, 1905.
- [139] N. Golinelli, A. Spaggiari, D. Castagnetti, L. Fornari, E. Dragoni, G. Gualdi, A. Brunazzi, *Proc. Inst. Mech. Eng. Part L: J. Mater.: Des. Appl.* **2019**, *233*, 714.
- [140] J.-K. Min, K.-H. Ahn, H.-C. Park, J.-B. Song, *Mechatronics* **2019**, *63*, 102265.
- [141] O. Persson, G. Persson, *Ph.D. Thesis*, Lund University, **2015**.
- [142] S. Seltmann, B. Muhammedi, A. Hasse, in *Proc. of 10th ECCOMAS Thematic Conf. on Smart Structures and Materials*, **2023**, pp. 1669–1680.
- [143] *DIN 6885: Passfedern*, Deutsches Institut für Normung e.V., Berlin **1968**.
- [144] G. Mroz, W. Reimche, W. Frackowiak, O. Bruchwald, H. Maier, *Proc. Technol.* **2014**, *15*, 484.
- [145] H. K. Mueller, *Fluid Sealing Technology*, Marcel Dekker, New York **1998**.
- [146] R. Flitney, *Seals and Sealing Handbook*, Elsevier, Amsterdam **2014**.
- [147] G. Streit, *Elastomere Dichtsysteme*, Vol. 4, Expert Verlag, Renningen **2011**.
- [148] K. Freudenberg Simrit, *Sealing Technol.* **2003**, *2003*, 1.
- [149] M. A. G. Abushagur, *Opt. Eng.* **1994**, *33*, 1074.
- [150] G. Krutz, T. Gallien, B. Newell, F. Stewart, in *Proc. of ASME/BATH 2013 Symposium on Fluid Power and Motion Control*, American Society of Mechanical Engineers, New York City **2013**, V001T01A001.
- [151] D. A. Cobb, *US5121929*, **1992**.
- [152] W. Liu, L. Gong, H. Yang, *Polym. Test.* **2021**, *96*, 107089.
- [153] M. Periyasamy, C. J. Quartapella, N. P. Piacente, G. Reichl, B. Lynn, *Sensors* **2023**, *23*, 1342.
- [154] M. K. Sunkara, *US5865971A*, **1997**.
- [155] M. Inman, A. K. Rawat, E. J. Taylor, P. J. Moran, Paper presented at *Corrosion 97*, New Orleans, Louisiana, March **1997**.
- [156] E. J. Taylor, M. Inman, *Electrochem. Soc. Interface* **2022**, *31*, 42.
- [157] D. J. Lines, J. M. Lawrie, J. P. O'Donoghue, *Proc. Inst. Mech. Eng.* **1966**, *181*, 185.
- [158] G. Upper, *Ph.D. Thesis*, Universität Stuttgart **1968**.
- [159] F. Gruber, Intelligente Wellen-Dichtungen mittels 3D-MID-Sensor-Integration, <https://www.3d-mid.de/neue-projektskizze-temperatursensor-fuer-dichtkontakte-ditempse/> (accessed: February 2023).
- [160] R. Heinzen, *US5246235A*, **1992**.
- [161] U. Reich, Leckage erkannt, Schaden gebannt, <https://www.fst.com/de/corporate/newsroom/pressemitteilungen/2021/leckage-erkannt-schaden-gebannt/> (accessed: February 2023).
- [162] U. Meinig, M. Geisau, E. Kammerer, *MTZ Worldwide* **2002**, *63*, 19.
- [163] KACO GmbH + Co. KG, loss (integrated oil seal with sensor), <https://kaco.de/en/products/ioss-integrated-oil-seal-with-sensor> (accessed: February 2023).
- [164] S. Thielen, Y. Stiemcke, B. Sauer, O. Koch, P. Sivasothy, J. Seewig, C. Rheinlaender, N. Wehn, in *Dresdner Maschinenelemente Kolloquium DMK 2022*, Technische Universität Dresden, Dresden **2022**.

- [165] B. Traber, Sensor or seal? - sealing material monitors its own wear, <https://process-technology-online.com/plant-processing/sensor-or-seal/> (accessed: February 2023).
- [166] Freudenberg Sealing Technologies, Stets im Bild, https://essential-may-2019.fst.de/22/?_ga=2.245749124.1038751655.1675429625-1902148810.1675429625 (accessed: February 2023).
- [167] Freudenberg Sealing Technologies, Redselige Dichtungen, <https://www.fst.com/de/corporate/magazin/digitalisierung/redselige-dichtungen>, (accessed: February 2023).
- [168] Freudenberg Sealing Technologies, Smart seal – the intelligent seal for valves, https://essential-may-2019.fst.de/22/?_ga=2.245749124.1038751655.1675429625-1902148810.1675429625 (accessed: February 2023).
- [169] U. Reich, Self-diagnosing seal, https://essential-may-2019.fst.de/22/?_ga=2.245749124.1038751655.1675429625-1902148810.1675429625 (accessed: February 2023).
- [170] J. Zhu, X. Li, S. Beamish, R. S. Dwyer-Joyce, *Tribol. Int.* **2022**, *167*, 107407.
- [171] T. Reddyhoff, R. Dwyer-Joyce, P. Harper, *Sealing Technol.* **2006**, *2006*, 7.
- [172] T. Reddyhoff, R. S. Dwyer-Joyce, P. Harper, *Tribol. Trans.* **2008**, *51*, 140.
- [173] L. A. Gupta, D. Peroulis, in *Proc. of 2012 42nd European Microwave Conf.* IEEE, Piscataway, NJ **2012**, pp. 424–427.
- [174] L. A. Gupta, L. Young, B. Wondimu, D. Peroulis, *Sens. Actuators, A* **2013**, *203*, 369.
- [175] EagleBurgmann Germany GmbH & Co. KG, Seal monitoring solutions - powered by eb smart seal sensor, <https://www.eagleburgmann.com/media/literature-competences-products-solutions/smartsealsensor-folder-eng> (accessed: February 2023).
- [176] H. Peeken, C. Troeder, *Elastische Kupplungen Ausführungen, Eigenschaften, Berechnungen*, Springer, Berlin **1986**.
- [177] VDI 2240:1971-06, *Wellenkupplungen; Systematische Einteilung nach ihren Eigenschaften*, Beuth Verlag GmbH, Berlin **1971**.
- [178] S. Schork, S. Gramlich, E. Kirchner, *DFX 2016: Proc. of the 27th Symp. Design for X*, The Design Society, Scotland **2016**, pp. 181–192.
- [179] J. D. M. Menning, A. Prokopchuk, A. Ewert, B. Schlecht, E.-F. M. Henke, T. Wallmersperger, in *Proc. of 10th ECCOMAS Thematic Conf. on Smart Structures and Materials SMART 2023*, (Eds: Patras, D. A. Saravanos, A. Benjeddou, N. Chrysochoidis, T. Theodosiou), European Community on Computational Methods in Applied Sciences, Barcelona **2023**, pp. 1611–1622.
- [180] A. Ewert, J. D. M. Menning, A. Prokopchuk, T. Rosenlöcher, M. E.-F. Henke, T. Wallmersperger, B. Schlecht, in *Proc. of 10th ECCOMAS Thematic Conference on Smart Structures and Materials*, European Community on Computational Methods in Applied Sciences, Barcelona **2023**, pp. 1681–1690.
- [181] A. Prokopchuk, A. Ewert, J. D. M. Menning, A. Richter, B. Schlecht, T. Wallmersperger, M. E.-F. Henke, in *Proc. of 10th ECCOMAS Thematic Conference on Smart Structures and Materials*, European Community on Computational Methods in Applied Sciences, Barcelona **2023**, pp. 1657–1668.
- [182] J. D. Menning, A. Ewert, A. Prokopchuk, B. Schlecht, M. Henke, T. Wallmersperger, *PAMM* **2023**, *23*, e202200141.
- [183] A. Prokopchuk, A. Ewert, J. D. M. Menning, A. Richter, B. Schlecht, T. Wallmersperger, E.-F. M. Henke, *Eng. Res. Express* **2023**, submitted.
- [184] J. Jung, D. J. Ryu, K.-S. Jeong, K.-h. Chang, *SAE Trans.* **2001**, *110*, 958.
- [185] K.-H. Lee, J.-E. Park, Y.-K. Kim, *J. Intell. Mater. Syst. Struct.* **2019**, *30*, 2212.
- [186] T. M. Syam, A. A. Hegazi, A. G. Muthalif, Y. Badri, *Trans. Can. Soc. Mech. Eng.* **2021**, *46*, 1.
- [187] L. Barik, S. Samal, A. Behera, D. K. Rajak, C. I. Pruncu, *ISSSJ. Micro Smart Syst.* **2021**, *10*, 87.
- [188] B. M. Kavlicoglu, F. Gordaninejad, X. Wang, *Smart Mater. Struct.* **2013**, *22*, 125030.
- [189] U. Lee, D. Kim, N. Hur, D. Jeon, *J. Intell. Mater. Syst. Struct.* **1999**, *10*, 701.
- [190] D. X. Phu, S.-B. Choi, *Front. Mater.* **2019**, *6*, 19.
- [191] T. Schneider, T. Kruse, B. Kuester, M. Stonis, L. Overmeyer, *Proc. Manuf.* **2018**, *24*, 135.
- [192] P. Groche, M. Brenneis, *Measurement* **2014**, *53*, 136.
- [193] W. Steinhilper, B. Sauer, *Konstruktionselemente des Maschinenbaus 1*, Springer, Berlin, Heidelberg **2012**.
- [194] DIN 13-1, *Metrisches ISO-Gewinde allgemeiner Anwendung*, Deutsches Institut für Normung, Berlin **1999**.
- [195] VDI 2230 Blatt 1: 2015-11, *Systematische Berechnung hochbeanspruchter Schraubenverbindungen: Zylindrische Einschraubenverbindungen*, Beuth Verlag GmbH, Berlin **2015**.
- [196] H. Wiegand, K.-H. Kloos, W. Thomala, *Schraubenverbindungen: Grundlagen, Berechnung, Eigenschaften, Handhabung, Konstruktionsbücher*, Vol. 5, 5th ed., Springer, Berlin **2007**.
- [197] T. Frank, A. Grün, M. Kermann, A. Cyriax, A. Steinke, T. Ortlepp, G. Reschke, in *20. GMA/ITG-Fachtagung Sensoren und Messsysteme 2019*, AMA Service GmbH, Wunstorf **2019**, pp. 153–158.
- [198] S. Biehl, N. Paetsch, E. Meyer-Kornblum, G. Bräuer, *Int. J. Instrum. Meas.* **2016**, *1*, 6.
- [199] Fraunhofer-Institut für Schicht- und Oberflächentechnik IST, Intelligente Schraubverbindung – Drahtlose und energieautarke Monitoringlösung, <https://www.ist.fraunhofer.de/de/referenzprojekte/intelligente-schraubverbindung.html> (accessed: July 2022).
- [200] M. Brenneis, P. Groche, *Adv. Mat. Res.* **2014**, *966–967*, 651.
- [201] ConSenses GmbH, Zeitgemäße Industriemesstechnik - smarte Lösungen| ConSenses industrial intelligence, <http://consenses.de> (accessed: March 2023).
- [202] F. Herbst, R. Chadda, C. Hartmann, J. Peters, D. Riehl, T. Gwosch, K. Hofmann, S. Matthiesen, M. Kupnik, in *Proc. of 2022 IEEE Sensors*, IEEE, Piscataway, NJ **2022**, pp. 1–4.
- [203] S. Horn, T. Gwosch, S. Matthiesen, *Beton- und Stahlbetonbau* **2021**, *116*, 1.
- [204] Sensorise GmbH, Sensorise smartscrew, <https://sensorise.de/solutions/smartscrew/> (accessed: April 2023).
- [205] U. Schmidt, *Ph.D. Thesis*, Leibniz Universität Hannover, Hannover **1985**.
- [206] R. Bauerochs, *Ph.D. Thesis*, Leibniz Universität Hannover **1989**.
- [207] R. X. Gao, B. T. Holm-Hansen, C. Wang, in *Photonics East (ISAM, VVDC, IEMB)* (Eds: P. F. Muir, P. E. Orban), SPIE, Bellingham **1998**, pp. 244–250.
- [208] B. T. Holm-Hansen, R. X. Gao, *J. Vib. Acoustics* **2000**, *122*, 384.
- [209] S. Marble, D. Tow, in *2006 IEEE Aerospace Conf.*, IEEE, Piscataway, NJ **2006**, pp. 1–7.
- [210] A. Shahidi, L. A. Gupta, A. Kovacs, D. Peroulis, in *Proc. of 2013 IEEE MTT-S Int. Microwave Symp. Digest (MTT)*, IEEE, Piscataway, NJ **2013**, pp. 1–4.
- [211] Y. Shao, L. Ge, J. Fang, in *Proc. of 2008 Int. Conf. on Control, Automation and Systems*, IEEE, Piscataway, NJ **2008**, pp. 1084–1089.
- [212] S. Scott, A. Kovacs, L. Gupta, J. Katz, F. Sadeghi, D. Peroulis, in *Proc. of 2011 IEEE 24th Int. Conf. on Micro Electro Mechanical Systems*, IEEE, Piscataway, NJ **2011**, pp. 660–663.
- [213] A. Albers, S. Beauvais, J. Bsul, W. Burger, in *Friction, Wear and Wear Protection* (Eds: A. Fischer, K. Bobzin), Wiley, Hoboken, NJ **2009**, pp. 467–472.
- [214] S. Emmrich, M. Plogmeyer, D. Bartel, in *Reibung, Schmierung Und Verschleiß- Aachen: GfT Gesellschaft Für Tribologie e.V.* Düsseldorf **2019**, pp. 1–4.
- [215] S. Emmrich, M. Plogmeyer, D. Bartel, C. Herrmann, *Sensors* **2021**, *21*, 6787.

- [216] S. Vogel, E. Kirchner, *Proc. Design Soc.: Int. Conf. Eng. Design* **2019**, 1, 3711.
- [217] T. Coors, F. Pape, G. Poll, in *Proc. IAMOT 2017*, Vienna **2017**, pp. 2040–2050.
- [218] F. Pape, T. Coors, G. Poll, Presented at Reibung, Schmierung Und Verschleiß, Forschung Und Praktische Anwendung Conf., Göttingen, September **2018**.
- [219] D. Klaas, R. Ottermann, F. Dencker, M. C. Wurz, *Sensors* **2020**, 20, 3294.
- [220] R. Ottermann, D. Klaas, F. Dencker, D. Hoheisel, S. Jung, A. Wienke, J. Duesing, J. Koch, M. C. Wurz, in *Proc. of IEEE Sensors*, IEEE, Piscataway, NJ **2021**, pp. 1–4.
- [221] D. Konopka, T. Steppeler, R. Ottermann, F. Pape, F. Dencker, G. Poll, M. C. Wurz, in *Proc. of 10th ECCOMAS Thematic Conf. on Smart Structures and Materials*, European Community on Computational Methods in Applied Sciences, Barcelona **2023**, pp. 1623–1634.
- [222] R. Ottermann, T. Steppeler, F. Dencker, M. C. Wurz, *Machines* **2022**, 10, 870.
- [223] J. Bethke, *Entwicklung einer praktisch einsetzbaren Meßtechnik für die Schmierfilmdicke in Wälzlagern und anderen tribologischen Systemen*, Universität Kaiserslautern, Kaiserslautern, Germany **1991**.
- [224] M. Barz, *Schmierfilmbildung in fettgeschmierten schnellaufenden Spindellagern*, Leibniz Universität Hannover, Hannover, Germany **1996**.
- [225] T. Schirra, G. Martin, S. Vogel, E. Kirchner, in *DS 92: Proc. of the DESIGN 2018 15th Int. Design Conf.*, The Design Studio, Scotland **2018**, pp. 3011–3022.
- [226] K. Jablonka, R. Glovnea, J. Bongaerts, *Tribol. Int.* **2018**, 119, 239.
- [227] S. Puchler, J. van der Kuip, E. Kirchner, *Tribol. Lett.* **2023**, 71, 38.
- [228] D. T. Matt, E. Rauch, *SME 4.0: The Role of Small- and Medium-Sized Enterprises in the Digital Transformation*, Springer International Publishing, Cham **2020**, pp. 3–36.
- [229] G. Martin, T. Schirra, E. Kirchner, Presented at the, *Bearing World, Int. Conf.*, Hannover, Germany, October **2020**.
- [230] V. Schneider, C. Behrendt, P. Höltje, D. Cornel, F. M. Becker-Dombrowsky, S. Puchler, F. Gutiérrez Guzmán, B. Ponick, G. Jacobs, E. Kirchner, *Lubricants* **2022**, 10, 194.
- [231] W. Lewicki, *Ph.D. Thesis*, University of London (Birkbeck College) **1955**.
- [232] A. Crook, *Philos. Trans. R. Soc., A* **1961**, 254, 223.
- [233] K. Jablonka, R. Glovnea, J. Bongaerts, *J. Phys. D: Appl. Phys.* **2012**, 45, 385301.
- [234] N. Bader, A. Furtmann, H. Tischmacher, G. Poll, Presented at, *STLE Annual Meeting & Exhibition*, Atlanta, Georgia, May **2017**.
- [235] F. M. Becker-Dombrowsky, Q. S. Koplín, E. Kirchner, *Lubricants* **2023**, 11, 304.
- [236] V. Schneider, H.-C. Liu, N. Bader, A. Furtmann, G. Poll, *Tribol. Int.* **2021**, 154, 106714.
- [237] T. Maruyama, M. Maeda, K. Nakano, *Tribol. Online* **2019**, 14, 327.
- [238] S. Schnabel, P. Marklund, I. Minami, R. Larsson, *Tribol. Lett.* **2016**, 63, 1.
- [239] G. Martin, F. M. Becker, E. Kirchner, *Tribol. Int.* **2022**, 170, 107503.
- [240] K. Scott, D. Infield, N. Barltrop, J. Coultate, A. Shahaj, in *50th AIAA Aerospace Sciences Meeting including the New Horizons Forum and Aerospace Exposition*, American Institute of Aeronautics and Astronautics, Reston, Virginia **2012**, p. 1293.
- [241] The Swedish Club, Main Engine Damage, https://www.swedishclub.com/media_upload/files/Loss (accessed: July 2023).
- [242] T. Schröder, *Ph.D. Dissertation*, RWTH Aachen **2021**.
- [243] S. Ni, in *Proc. of 2022 Int. Conf. on Manufacturing, Industrial Automation and Electronics (ICMIAE)*. IEEE, Piscataway, NJ **2022**, pp. 24–32.
- [244] I. Jonuschies, *Ph.D. Dissertation*, Universität Rostock **2015**.
- [245] A. Rolink, T. Schröder, G. Jacobs, D. Bosse, J. Hölzl, P. Bergmann, *J. Phys.: Conf. Ser.* **2020**, 1618, 052002.
- [246] Iigus, New range of plain bearings for predictive maintenance, <https://www.igus.com/info/news-2019-iglidur-plain-bearings-isense> (accessed: March 2023).
- [247] NTN global corporation, Development of “integrated rotation sensor sliding bearing” enables reliable and easy monitoring of rotation status, https://www.ntnglobal.com/en/news/new_products/news201100038.html (accessed: July 2023).
- [248] DIN 31652-1, *Gleitlager – Hydrodynamische Radial-Gleitlager im stationären Betrieb: Teil 1: Berechnung von Kreiszyllindernagern*, Deutsches Institut für Normung e.V., Berlin **2017**.
- [249] VDI 2204 Blatt 2:1992-09, *Design of Plain Bearings; Calculation*, Beuth Verlag GmbH, Berlin **1992**.
- [250] DIN 31652-3, *Gleitlager – Hydrodynamische Radial-Gleitlager im stationären Betrieb: Teil 3: Betriebsrichtwerte für die Berechnung von Kreiszyllindernagern*, Deutsches Institut für Normung e.V., Berlin **2017**.
- [251] N. Mokhtari Molok Abadi, *Überwachung hydrodynamischer Gleitlager basierend auf der Körperschallanalyse*, *Advances in Automation Engineering*, Vol. 7, Universitätsverlag der TU Berlin, Berlin **2020**.
- [252] J. Deckers, *Ph.D. Dissertation*, Gerhard-Mercator-Universität Duisburg **2001**.
- [253] S. A. Mirhadizadeh, *Ph.D. Dissertation*, Cranfield University **2012**.
- [254] P. Raharjo, *Ph.D. Dissertation*, University of Huddersfield **2013**.
- [255] F. König, J. Marheineke, G. Jacobs, C. Sous, M. J. Zuo, Z. Tian, *Wear* **2021**, 476, 203616.
- [256] A. Sturm, R. Förster, *Maschinen- und Anlagendiagnostik: Für die zustandsbezogene Instandhaltung*, Vieweg+Teubner Verlag, Wiesbaden **1990**.
- [257] C. Bueren, M. Humer, in *VDI Schadensmechanismen an Lagern 2018*, VDI-Verlag, Nordrhein-Westfalen **2018**.
- [258] G. Abraham, K. Franek, *Schmierungstechnik* **1989**, 20, 75.
- [259] M. Neu, A. Harder, E. Kirchner, in *Gleit- und Wälzlagerungen 2019*, VDI Verlag, Nordrhein-Westfalen **2019**, pp. 183–192.
- [260] H. T. Nguyen, *Ph.D. Dissertation*, Karlsruher Institut für Technologie, Karlsruhe **2013**.
- [261] Schaller Automation, Bearomos 2020 - Bearing monitoring system for oil-lubricated slide bearings, https://schaller-automation.com/en/wp-content/uploads/sites/2/2018/10/Brosch%CC%88re_Bearomos_102019_EN_Web.pdf (accessed: July 2023).
- [262] F. Klocke, *Fertigungsverfahren 1: Zerspanung mit geometrisch bestimmter Schneide*, VDI-Buch, Springer Vieweg, Berlin **2017**.
- [263] M. Fritz, W. Burger, A. Albers, in *Tribologie Fachtagung Reibung, Schmierung und Verschleiß*. Universität Karlsruhe, Karlsruhe **2001**, pp. 1–9.
- [264] DIN 31692-2, *Gleitlager - Teil 2: Temperaturüberwachung*, Deutsches Institut für Normung e.V., Berlin **1996**.
- [265] J. Marheineke, F. Gutierrez Guzman, T. Baszenski, T. Gemmeke, G. Jacobs, K. Kauth, K. Kratz, in *Dresdner Maschinenelemente Kolloquium - DMK 2022* (ed: B. Schlecht), Sierke Verlag, Göttingen **2022**.
- [266] DIN 31652-2, *Gleitlager - Hydrodynamische Radial-Gleitlager im stationären Betrieb: Teil 2: Funktionen für die Berechnung von Kreiszyllindernagern*, Deutsches Institut für Normung e.V., Berlin **2017**.
- [267] C. Winkelmann, O. Woitschach, E.-M. Meyer, W. Lang, in *Proc. of 2011 16th Int. Solid-State Sensors, Actuators and Microsystems Conf.*, IEEE, Piscataway, NJ **2011**, pp. 1080–1083.
- [268] M. Nässelqvist, R. Gustavsson, J.-O. Aidanpää, *Exp. Mech.* **2012**, 52, 361.



Eckhard Kirchner, studied mechanical engineering and applied mechanics at the former TH Darmstadt and at the Norwegian Institute of Technology in Trondheim. In 1999, he received his doctorate from the TU Darmstadt. After industrial activities in the field of transmission and drive system development he was appointed university professor for product development and machine elements at TU Darmstadt in 2016. His research interests focus on sensory machine elements and the necessary product development methods and the design of components for additive manufacturing. Prof. Kirchner is a full member of the Scientific Society for Product Development WiGeP since 2019.



Thomas Wallmersperger is a full professor for Mechanics of Multifunctional Structures at TU Dresden (since 2011), and Associate Dean of the Faculty of Mechanical Science and Engineering since 2016. His research topics comprise coupled multi-field problems, adaptive materials and smart structures, modeling and simulation of soft and hard materials. Dr. Wallmersperger completed his dissertation in 2003 and his habilitation in 2010 at University of Stuttgart, Germany. Professor Wallmersperger is Associate Editor of the 'Journal of Intelligent Material Systems and Structures', Editorial Advisory Board Member of 'Acta Mechanica', and Program Committee Member for the SPIE-Conference 'Electroactive Polymer Actuators and Devices'.



Thomas Gwosch graduated as a mechanical engineer (M.Sc.) at the Karlsruhe Institute of Technology (KIT) in 2014 and received his doctoral degree (Dr.-Ing.) in 2019. He worked for 3 years as a postdoc at the Institute of Product Engineering at KIT. Until 2023 he was spokesman of the working group Microsystems Technology of the DFG priority program 2305. Since mid-2023, he works as a mechatronics engineer in the semiconductor manufacturing technology. Thomas Gwosch has many years of research experience in testing and validation of advanced mechatronic systems with a focus on sensors, measurement and control.



Johannes Menning is a research assistant at the Chair of Mechanics of Multifunctional Structures at TU Dresden. After finishing his Diploma in Mechanical Engineering at TU Dresden in 2021, he started working on his Dissertation in the field of modeling and simulation of sensor-integrating elastic couplings. His research topics include numerical modeling and simulation of active and passive structures, as well as of smart materials such as dielectric elastomers or carbon nanotubes. In 2023, Mr. Menning was part of the main Organizing Team for the 93rd Annual Meeting of the International Association for Applied Mathematics and Mechanics in Dresden.



Karsten Stahl is a full professor at the Institute for Machine Elements of the TUM and director of the Gear Research Center FZG. His research focuses on experimental and analytical investigations of endurance, tribology, NVH, materials and condition monitoring on gears, transmission components and drive systems with the target of developing methods and tools for reliable determination of fatigue life, efficiency, and vibration characteristics. Prof. Stahl is the author of several hundred scientific publications, board member of scientific associations, convener of DIN and ISO working groups, editor of scientific journals and president of the VDI International Conference on Gears.